



CAMDENCOUNTY

new energy. new vision.

***BOARD
OF
COMMISSIONERS***

March 06, 2017

7:00 PM

Regular Meeting

Historic Courtroom

Courthouse Complex

This agenda is only a tentative schedule of matters the Commissioners may address at their meeting and all items found on it may be deleted, amended or deferred. The Commissioners may also, in their absolute discretion, consider matters not shown on this agenda.

Special accommodations for the disabled who attend public meetings can be made by contacting the Clerk to the Board 24 hours in advance at 252-338-6363, Ext. 100.

Please turn Cell Phone ringers off during the meeting

CAMDEN COUNTY BOARD OF COMMISSIONERS

Agenda

*7:00 PM- Regular Meeting
March 06, 2017
Historic Courtroom, Courthouse Complex*

7:00 P.M. CALL TO ORDER & WELCOME

Chairman Clayton Riggs

INVOCATION & PLEDGE OF ALLEGIANCE

Commissioner Garry Meiggs

ITEM 1. PUBLIC COMMENTS

It is requested that comments be limited to (2-3) minutes. The length and number of comments may be limited upon the Chairman's discretion due to scheduling and other issues.

ITEM 2. CONSIDERATION OF AGENDA (For discussion and possible action)

ITEM 3. PRESENTATIONS (For discussion and possible action)

A. *Presentation by Gary Hobbs - American Red Cross.....(Pgs. 6-7)*

B. *2016 Year in Review
Cameron Lowe, NC Cooperative Extension.....(Pg. 8)*

C. *Presentation by Brian Lannon - Watershed Projects.....(Pgs. 9-10)*

- ITEM 4. OLD BUSINESS (For discussion and possible action)**
- A. Recommendation on RFQ for Architectural/Engineering (A/E) Services - Michael Brillhart (Pgs. 11-13)

- ITEM 5. PUBLIC HEARINGS**
- A. RECONVENE Public Hearing - Special Use Permit Application (UDO 2016-08-10) Mining Operation for B&M (Pgs. 14-58)

- ITEM 6. NEW BUSINESS (For discussion and possible action)**
- A. FY 15-16 County Audit by Greg Allison Thompson, Price, Scott, Adams, & Co., PA (Pgs. 59-202)
 - B. Monthly Tax Report - January 2017 - Lisa Anderson (Pgs. 203-210)
 - C. Annual Report & Resolution No. 2017-02-03 Bland Baker, Trillium Health Resources..... (Pgs. 211-231)
 - D. Brand Change- Camden County Eco Industrial Park Charlie Bauman..... (Pgs. 232-233)

- ITEM 7. BOARD APPOINTMENTS (For discussion and possible action)**

- ITEM 8. CONSENT AGENDA**
- A. 2016-11-21 BOC Minutes – Draft..... (Pgs. 234-262)
 - B. 2017-02-20 BOC Minutes – Draft..... (Pgs. 263-295)
 - C. 16-17 Budget Amendments (Pgs. 296-299)
 - D. CCS Budget Amendments (Pgs. 300-304)
 - E. VTS Refunds Over \$100.00 (Pgs. 305-307)
 - F. DMV Monthly Report - April Renewals (Pgs. 308-309)
 - G. Proclamation - National County Government Month (Pgs. 310-284)
 - H. Proclamation: American Red Cross Month 2017..... (Pgs. 348-349)

ITEM 9. Commissioners' Report

ITEM 10. County Manager's Report

- A. Status Report on RFQ for Construction Manager at Risk (CMR) Services - Michael Brillhart..... (Pgs. 350-351)

ITEM 11. INFORMATION (Reports & Minutes from other Agencies)

- A. January 2017 Library Statistics..... (Pgs. 352-354)
- B. EMS Reports..... (Pgs. 355-360)
- C. ARPO Transportation Update..... (Pgs. 361-367)
- D. National Association of Counties (Pgs. 368-369)
- E. March for Meals..... (Pgs. 370-371)
- F. FY 16-17 Sales Tax Revenue Collections..... (Pgs. 372-373)
- G. Sheriffs Monthly Report - January 2017..... (Pgs. 374-375)
- H. MOA Program Calendar Feb - Apr 2017..... (Pgs. 376-381)

ITEM 12. OTHER MATTERS (For discussion and possible action)

ITEM 13. ADJOURN



Board of Commissioners
AGENDA ITEM SUMMARY SHEET

Presentations

Item Number: 3.A

Meeting Date: March 06, 2017

Submitted By: Angela Wooten, Clerk to the Board
Administration
Prepared by: Angela Wooten

Item Title **Presentation by Gary Hobbs - American Red Cross**

Attachments: Microsoft Outlook - Memo Style (PDF)

Presentation by: Gary Hobbs
American Red Cross

Consent Agenda Item 8.F - Proclamation: American Red Cross Month 2017

Angela Wooten

From: Self, Carolyn J. <carolyn.self2@redcross.org>
Sent: Tuesday, February 14, 2017 10:26 AM
To: info@camdencountync.gov
Subject: RedCross proclamation
Attachments: mircm-localizable-mayoral-proclamation.docx

The American Red Cross would like to have this proclamation at your March 6, 2017 commissioners meeting at 7:00 p.m.. The person representing the Red Cross for the proclamation will be Gary Hobbs a volunteer for our chapter. We would like to thank you for your support of the American Red Cross.

Carolyn Self
Community Volunteer Leader | Greater Albemarle Area

Eastern NC Region
1409-B Parkview Drive
Elizabeth City, NC 27909
Tel. (252) 335-2185
Cell (252) 333-2588

Attachment: Microsoft Outlook - Memo Style (1565 : Presentation by Gary Hobbs - American Red Cross)



CAMDENCOUNTY

new energy. new vision.

Board of Commissioners AGENDA ITEM SUMMARY SHEET

Presentations

Item Number: 3.B
Meeting Date: March 06, 2017

Submitted By: Cameron Lowe, Cooperative Extension Director
NC Cooperative Extension
Prepared by: Angela Wooten

Item Title 2016 Year in Review – Cameron Lowe, NC Cooperative Extension

Attachments:

Presentation by: Cameron S. Lowe
County Extension Director
NC Cooperative Extension

Summary: 2016 Year in Review



CAMDENCOUNTY

new energy. new vision.

Board of Commissioners AGENDA ITEM SUMMARY SHEET

Presentations

Item Number: 3.C

Meeting Date: March 06, 2017

Submitted By: Michael Brillhart, County Manager
Administration
Prepared by: Angela Wooten

Item Title Presentation by Brian Lannon - Watershed Projects

Attachments: Watershed Projects (PDF)

Presentation by: Brian Lannon
Soil & Water Technician

24000

Summary of Watershed Projects

North River Watershed

4/11/2016	Run Swamp Canal – Buckhorn Ditch around bend to Hwy 34 culverts	\$13,275
10/16/2015	Run Swamp Canal – bend to Hwy 34 culverts	\$ 2,360
2/10/2015	Run Swamp Canal – Hwy 34 to Indiantown Creek (State Funds)	\$10,000
4/19/2013	Buckhorn Ditch to Indiantown Road (Farmer Funded)	\$ 8,976

Sawyer's Creek Watershed

8/26/2015	Seymour Drive to NC 158	\$11,760
8/26/2016	Scotland Road to Sawyer's Creek Road & Spur	\$22,125

Shiloh Watershed

8/26/2015	Trotman Road to Portahonk Creek & Tributary	\$7,938
	Dailey Road to Pasquotank River	\$7,644
5/2/2016	Barlett's Landing to Pasquotank River	\$9,440

South Mills Watershed

8/26/2015	Elm Street to Water Plant Shed	\$8,526
	Main Street to Water Plant Shed	
3/28/2016	NC 343 North to Joyce Creek	\$12,390



CAMDENCOUNTY

new energy. new vision.

Board of Commissioners AGENDA ITEM SUMMARY SHEET

Old Business

Item Number: 4.A
Meeting Date: March 06, 2017
Submitted By: Michael Brillhart, County Manager
 Administration
 Prepared by: Angela Wooten

Item Title **RFQ for Architectural/Engineering (A/E) Services**

Attachments:

Summary:

An RFQ for Architectural & Engineering Services was advertised specific to the design of a new county Public Services Building to be located along North Highway 343 across from the Old Courthouse. Camden County received four (4) proposals all of which met the required minimum qualifications as specified within the RFQ. Each firm was scored on the Initial Criteria to determine the highest qualified submission.

Architect/Design Initial Criteria from RFQ Announcement:

1. Specialized, appropriate expertise for this type of project.
2. Organizational chart and project team expertise.
3. Proposed design approach and innovative design solutions for projects of this type.
4. Project quality control plan including recent experience with cost control, change orders, and maintaining design and construction schedules.
5. Current workload of firm's personnel.
6. Record of successfully completed projects without major legal or technical problems.
7. Capabilities and proven experience in extensive evaluation of facilities energy consumption and life cycle analyses during design of similar projects.
8. Compliance with proposal format requirements.
9. Experience working on projects utilizing Construction Management at Risk construction delivery method.
10. Proximity to and familiarity with Camden County area.
11. (50%) Minority/Women Owned Business



Scoring:

Firm	Initial Score
VIA Design Architects	51
HBA Architecture	51
Oakley Collier Architects	49.5
Bommerang	41

A Selection Committee, consisting of County staff, rated the four firms and chose three firms for the interview process to determine which of the three firms provided the best qualifications for our needs. Based upon the interviews conducted with each company, the highest scoring firm was VIA Design Architects.

Interview Panel Scores:

Firm	Final Score (0-3)
VIA Design Architects	Avg 2.61
HBA Architecture	Avg 2.32
Oakley Collier Architects	Avg 2.25
Bommerang	-

Noted Strengths for VIA:

- Their team will consist of assistance from local firms such as East Carolina Engineering.
- VIA was well prepared, cohesive, and excited about the proposed project.
- 25 years of Experience
- Budget Sensitive
- Community and Employee Involvement Experience
- Library, Historical & Community Emphasis
- Historically Underutilized Business (50%+ Female Owned)

**Recommendation:**

In accordance with the state mandated RFQ process, the next step is to conduct negotiations with the highest scoring firm for the proposed fee for services. With board approval, staff will commence with the necessary steps for securing VIA's proposal for services.

- 1. Motion to accept staff's recommendation and allow staff to commence with the necessary steps for securing VIA Design Architects' proposal for services.**
- 2. Determine availability for Commissioners to meet with approved firm for an introductory presentation:**

Proposed Date/Time: March 20, 2017 9:30 am



Board of Commissioners
AGENDA ITEM SUMMARY SHEET

Item Number: 5.A
Meeting Date: March 06, 2017

Submitted By: Dave Parks, Permit Officer
 Planning & Zoning
 Prepared by: Angela Wooten

Item Title **Reconvene Public Hearing - Special Use Permit Application (UDO 2016-08-10) Mining Operation for B&M**

Attachments: Agenda Summary SUP Mining Operation (PDF)
 SUP Conditions Mining SUP.docx (PDF)
 UDO 2016-08-10 Findings of Facts(PDF)
 UDO 2016-08-10 Bright Mine - Meiggs Tract (PDF)

Summary:

B&M Investments of NC, LLC was issued a Special Use Permit on July 16, 2007 for a Mining Operation at/near the end of Ponderosa Road. Due to the down turn in the economy and the demand for materials, the Special Use Permit expired. This is a new SUP application for the same use at the same location.

Planning Board met on October 19, 2016 to consider the Special Use Permit application and after discussion with staff, adjacent property owners and applicant, Planning Board tabled the application for consideration at their next meeting. On November 16, 2016, Planning Board recommended approval of the Special Use Permit application with the conditions as stated in Staffs Findings on a 6-0 vote.

At the January 3, 2017 Board of Commissioners meeting the Public Hearing was recessed and staff was directed to facilitate a meeting with applicant, adjacent property owner and Camden Yard Materials to come up with conditions on the maintenance and upkeep of Ponderosa Road.

Meeting held on Monday, January 30, 2017 at 6:00 PM. See attached.



Recommendation:

Reconvene Public Hearing.

Camden County Board of Commissioners AGENDA ITEM SUMMARY SHEET

MOTION MADE BY:	
C. Riggs	_____
T. White	_____
G. Meiggs	_____
R. Krainiak	_____
R. Munro	_____
NO MOTION	_____
VOTE:	
C. Riggs	_____
T. White	_____
G. Meiggs	_____
R. Krainiak	_____
R. Munro	_____
ABSENT	_____
RECUSED	_____

Attachment: Agenda Summary SUP Mining Operation (1504 : Reconvene Public Hearing - Special Use Permit Application (UDO 2016-08-10)

Item Number:

Meeting Date: January 3, 2017
Attachments: SUP Findings of Facts with supporting documents
Submitted By: Planning Department

ITEM TITLE: Public Hearing – Special Use Permit
 Application (UDO 2016-08-10) Mining
 Operation for B&M Investments of NC, LLC

SUMMARY:

B&M Investments of NC, LLC was issued a Special Use Permit on July 16, 2007 for a Mining Operation at/near the end of Ponderosa Road. Due to the down turn in the economy and the demand for materials, the Special Use Permit expired. This is a new SUP application for the same use at the same location.

Planning Board met on October 19, 2016 to consider the Special Use Permit application and after discussion with staff, adjacent property owners and applicant, Planning Board tabled the application for consideration at their next meeting. On November 16, 2016, Planning Board recommended approval of the Special Use Permit application with the conditions as stated in Staffs Findings on a 6-0 vote.

RECOMMENDATION:

- 1) Hold Public Hearing.
- 2) Motion to amend agenda for consideration.

Meeting Summary Notes

January 30, 2017 6:00 PM

UDO Ponderosa Road Issues

The purpose of this meeting was to discuss issues related maintenance of Ponderosa RD if the Mining SUP application is approved.

Present:

Garry Meiggs & wife	Applicant
Jereme Rosenberger & wife	Neighboring property owners
Chris Coleman	Owner Camden Yard Materials
Dan Porter	Planning Director
Dave Parks	Permit Officer

Mr. Parks opened the meeting and read the staff recommendations and invited discussion of each item below.

In general the applicant, Mr. Meiggs, did not object to the conditions with the exception of using trip logs to determine proration of costs. He did request that the paving condition allow for use of asphalt millings in place of actually paving that portion of road.

While the Rosenberger's and Mr. Coleman each had suggestions about suggested conditions, their stated position is that Ponderosa Rd. is currently unsafe because it is too narrow for two vehicles to pass. With one mine operating the unsafe condition is exacerbated by the heavy trucks and frequency of truck hauling. Permitting a second mine on the same road would be disastrous.

Below are the recommended conditions and the feedback received.

Recommended Additional Conditions

1. The applicant shall pave to NCDOT construction standards a 400' section of Ponderosa Drive from the entrance to the mine west towards U.S. 17.

How wide should the paving be? The previously approved Camden Yard Materials was required to pave the portion of Ponderosa road 22 feet wide for the distance that the road travels adjacent to residential homes. The applicant requested that he be allowed to use asphalt millings rather than actually paving the road.

Staff recommendation is as stated above with the addition that the paving shall be 20 feet wide.

2. The applicant shall improve to NCDOT unpaved constructions standards that portion of Ponderosa Drive starting 400' west of the entrance to the mine to eastern property line of Camden Yard Materials.

Mr. Coleman stated that he had improved the road from where the pavement stopped behind Heritage Court Subdivision to his mine entrance using asphalt or concrete millings as base material for the road. The recommendation would leave and unimproved gap from his mine entrance to his eastern property boundary. The Rosenberger's stated that the condition of the road was a minor item compared to the narrow road which could lead to serious accidents.

Staff recommends extending the improved conditions all the way to the entrance of Camden Yard Materials.

3. The applicant shall be responsible for any failures to the road improvements mentioned in conditions above. Road failures shall be corrected within 30 days once identified.

After discussion all parties agreed that road failures will be corrected within 24 hours of the county providing notice to the active mining operations. Mr. Meiggs offered that complainants are welcome to call him about any problems for his immediate attention.

4. Applicant shall install a six (6) foot wooden fence along the front property line of property now or formerly owned by Rosenberger and Roberts. Property owners shall be responsible for the maintenance of fence.

The Rosenberger's did not appear to object to a fence but are concerned that it might encroach on their septic field which is their front yard.

5. The applicant shall cause to be created and maintained and eight (8) foot wide vegetated buffer immediately south of the fence. Such buffer shall include trees with a preference of heavily year round leafy trees at a planting height of at least 8 feet with minimum of 1 ½ inch in diameter. The applicant shall maintain the vegetated buffer at all times during the term of the permit.

The Rosenberger's do want a buffer installed but are concerned about root intrusion into their drain field. *(a field check on Jan 30 indicated that they have a tree planted in the front yard and it does not appear that the landscaping would be any closer to the drain field than the tree)*

6. The applicant shall install 10 MPH speed limit signs at a point 500' prior to the entrance to the mine and at the exit from the mine.

No objections or concerns other than importance of mining operators need to enforce the speed limit.

7. Private vehicles shall have the right of way at all times when traveling along Ponderosa Drive.

All parties agreed that this was very important but once again it was emphasized that the narrow road does not allow for two vehicles to pass and requires that one vehicle pull off the road a bit into the farm field. (A field check on Jan 30 indicated there are adequate areas for the dump trucks or owners can pull off to allow for the passing of vehicles. Also there is a clear line of site with no obstructions to observe oncoming vehicles)

Maintenance Agreement

The maintenance/upkeep of Ponderosa Drive shall be done on a quarterly basis (Starting in January of each year) or as needed as determined by Camden County Code Enforcement Officer by Camden Yard Materials and B & M Investments of NC, LLC. Costs involved will be determined by the number of trips conducted by each business for that period of time. Copies of the trip log will be provided to the County to determine costs for each business.

(Please understand that this meeting lasted 2 hours with a considerable amount of heated give and take conversations, and no final formal agreement was achieved. The note takers have used editorial discretion to summarize the key issues. The staff recommendations have been prepared based on input from all parties as well as staff's overall evaluation of the project.)

**UDO 2016-08-10
Special Use Permit
Findings of Facts**

PROJECT INFORMATION

File Reference: UDO 2016-08-10
Project Name; Mining Operation
PIN: 01-7082-00-68-8936
Applicant: B & M Investments
Of NC, LLC
Address: 1075 N. Hwy 343
South Mills, NC
Phone: (252) 771-5634
Email:

Agent for Applicant:
Address:
Phone:
Email:

Current Owner of Record: Same as applicant.

Meeting Dates:
9/21/2016 **Planning Board**
Board of Commissioners

Application Received: 8/18/2016
By: David Parks, Permit Officer

Application Fee paid: \$400 Check # 6322

Completeness of Application: Application is generally complete

Documents received upon filing of application or otherwise included:

- A. Land Use/Development Application
- B. Mine Development Plan
- C. Aerial/Zoning Map
- D. Copy of expired SUP issued July 16, 2007
- E. NCDENR Mining Permit No. 15-12
- F. U.S. Army Corps of Engineers Permit

PROJECT LOCATION:

Street Address: End of Ponderosa Drive
Location Description: South Mills Township

REQUEST: Mining Operation (Use #14.300). Owners were granted a Special Use Permit (UDO 2007-05-15) for the mining operation which was approved by the Board of Commissioners on July 16, 2007. With the length of time to obtain NCDENR/Army Corps permits and down turn in the economy the Special Use Permit has expired.

SITE DATA

Lot size: Approximately 113 acres in size
Flood Zone: X
Zoning District(s): Light Industrial (I-1)
Existing Land Uses: Woodland

Adjacent Zoning & Uses:

	North	South	East	West
Zoning	State of Virginia	Light Industrial (I-1)	Light Industrial (I-1)	Light Industrial I-1
Use & size	Woodland	Woodland/Farms over 23 acres	Woodland – approximately 95 acres	Single Family Dwelling – 10 acres

Proposed Use(s): Mining Operation

Description of property:

Property is a wooded parcel located at the VA/NC Boarder

ENVIRONMENTAL ASSESSMENT

Streams, Creeks, Major Ditches:

Distance & description of nearest outfall:

Nearest outfall is Dismal Swamp Canal

Soils:

Predominant: Hyde (HyA)
Other: Belhaven Muck (BaA)

INFRASTRUCTURE

There are currently no utilities servicing the property.

Traffic: There will be a significant increase of traffic flow on Ponderosa Road

1. Utilities:

- A. **Does the application include a letter or certificate from the District Health Department regarding septic tanks?** Applicant requesting use of portable toilet.
- B. **Does the applicant propose the use of public sewage systems?** No
- C. **Does the applicant propose the use of public water systems?** No.
- D. **Distance from existing public water supply system:** Approximately 4.5 miles (Camden ECO Park).
- E. **Is the area within a five-year proposal for the provision of public water?** No
- F. **Is the area within a five-year proposal for the provision of public sewage?** No

2. Landscaping

- A. **Is any buffer required?** Yes. Indicated on site plan.
- B. **Is any landscaping described in application:** N/A

3. Findings Regarding Additional Requirements:

- A. **Endangering the public health and safety:** If ingress/egress is proposed off Ponderosa Road (Private) staff feels that with the width of Ponderosa Road (30' easement) and current road conditions, proposed use will have an impact on the residents that utilize the road if not kept up to drivable standards.
- B. **Injure the value of adjoining or abutting property:** Staff's opinion is that the proposed use will not injure the values of adjoining properties.
- C. **Harmony with the area in which it is located:** Yes. The property is zoned for the proposed use. There was a Special Use Permit issued (attached) by the County for the same use.
- D. **Conformity with the Plans**
 - (1). Land Use Plan – Area is consistent with County's Future Land Use Map for proposed use.
 - (2). Thoroughfare Plan – Only access to site is off Ponderosa Road (Private 30' easement).
 - (3). Other Plans officially adopted by the Board of Commissioners – N/A
- E. **Will not exceed the county's ability to provide public facilities**
 - (1). Schools – No impact.
 - (2). Fire and rescue – Little impact.
 - (3). Law Enforcement – Little impact.
- F. **Other County Facilities** – N/A

Planning Staff is recommending approval to re-issue a new Special Use Permit with the following conditions (taken from previous Special Use Permit):

- 1. The applicant must strictly abide by all requirements of the Unified Development Ordinance of Camden County, North Carolina, and must also strictly comply with all other local, state, and federal ordinances, laws, rules and regulations as one or more ordinances, laws, rules and regulations may apply to this development.
- 2. The applicant shall complete the development strictly in accordance with the approved plans contained in the file titled UDO 2016-08-10.
- 3. Applicant shall aid in maintaining the upkeep of Ponderosa Road to current conditions.

4. Applicant shall retain the cut over trees that lay within the buffer area indicated on site plans.
5. Hours of operations shall be: April 1 – October 31, 7:00 AM-6:00 PM, Monday thru Friday and; November 1 – March 31, 7:00 AM – 5:00 PM, Monday thru Friday.
6. If any of the conditions affixed hereto or any part thereof shall be held invalid or void, then this approval in its entirety shall be void and have no effect.



Land Use/Development Application

County of Camden, North Carolina

Depending upon the type of proposal, the proposal may require a Zoning Permit, Conditional Use Permit, or Special Use Permit. This form is used as the start of application process. All applicants must submit a site plan (see "Minimum Site Plan Requirements") and a valid Health Department permit. Applicants for a Conditional Use Permit or Special Use Permit should review the "Requirements for Conditional Use Permit and Special Use Permit Applications".

Applicants for a subdivision must submit this form as their Special Use Permit application.

Please consult the Planning Office (1-252-338-1919) with any questions about your application.

Please Do Not Write in this Box	
PIN:	<u>01-7082-00-68-8936</u>
UDO#	<u>2016 - 08 - 10</u>
Date Received:	<u>8/18/2016</u>
Received by:	<u>DP</u>
Zoning District:	<u>Light Industrial - 11</u>
Fee Paid \$	<u>400.00</u>

PLEASE PRINT OR TYPE

PK CK # 6322

Applicant's Name: B & M Investments of NC LLC

If the Applicant is acting as agent for another person (the "principal"), please give that person's name on the line below and submit a copy of the agency agreement/letter with this Application.

Applicant's Mailing Address: 1075 N. Highway 343
South Mills, NC 27976

Daytime Phone Number: (252) 771-5634

Street Address Location of Property: End of Ponderosa Road, South Mills Township

General Description of Proposal: Mining Operation - Use #14.300 - 54P

I swear or affirm that the foregoing information and all attachments hereto (now or subsequently provided as part of this application) are true and correct to the best of my knowledge.

Signed: *Sandy W. Meigs*
Dated: *8/18/16*

* Information to be filled out by Planning Department

*Is the Property in a Watershed Protection area? No

*Flood Zone (from FIRM Map): X *Taxes paid? no

FILED in Camden County, NC
on Aug 20 2007 at 01:18:40 PM
by: Peggy C. Kight
Register of Deeds
BOOK 253 PAGE 497

**AN ORDER GRANTING A
SPECIAL USE PERMIT
BY THE BOARD OF COMMISSIONERS
CAMDEN, NORTH CAROLINA**

The Board of Commissioners for the County of Camden, North Carolina, having held a public hearing on Monday, July 16, 2007 to consider an application for a Special Use Permit by B & M Investments of NC LLC and having heard all of the evidence presented at the hearing makes the following FINDINGS OF FACT and draws the following CONCLUSIONS:

It is the Board's CONCLUSION that the Special Use Permit be issued subject to certain conditions listed below.

This CONCLUSION is based upon the following FINDINGS OF FACT:

1. **Name of Applicant:** B & M Investments of NC LLC
2. **Agent for Applicant:** Gary Meiggs
3. **Address of Agent:** 1075 North Highway 343
South Mills, NC 27976
4. **PIN:** 01-7082-00-68-8936
5. **Name(s) of Current Owner(s) of Record:** B & M Investments of NC, LLC
6. **Street Address of Property:** Not addressed
7. **Location of Property:** Adjacent to 370 Ponderosa Road
8. **Flood Zone:** X
9. **Zoning District(s):** Light Industrial (I-1)
10. **Is a Zoning Change Required for the Proposed Use?** No

UDO2007-05-15
Mining Operation
Page 1 of 5

BOOK 253 PAGE 498

11. **General Description of the Proposal:** Mining Operation – “Bonney Bright Sand”
12. **Table of Permissible Use #:** 14.300
13. **Date Application Received by County:** May 8, 2007
14. **Did the Applicant participate in a pre-application Conference?** Yes
15. **Received by:** Dave Parks, Permit Officer
16. **Application fee paid:** \$400.00 by check # 1601
17. **Completeness of Application:** Application is generally complete.
18. **Documents received upon filing application or otherwise included:**
 - A. Land Use/Development Application
 - B. Deed
 - C. GIS Map
 - D. 10 Copies Proposed Commercial Site Plan
19. **Soil Classifications:**

Predominant: Hyde (HyA) Severe wetness, percs slowly
Other: Belhaven (BaA) Severe wetness, percs slowly
20. **Adjacent Property Uses:**
 - A. **Predominant:** Agriculture
 - B. **Other:** Some residential exists adjacent to property
21. **Existing Land Uses:** Timber
22. **Utilities:**
 - A. **Does the application include a letter or certificate from the District Health Department regarding septic tanks?** No.
 - B. **Does the applicant propose the use of public sewage systems?** No.
 - C. **Does the applicant propose the use of public water systems?** No.
 - D. **Distance from existing public water supply system:** Area not serviced.
 - E. **Is the area within a five-year proposal for the provision of public water?** No
 - F. **Is the area within a five-year proposal for the provision of public sewage?** No
23. **Landscaping:**
 - A. **Is any buffer required?** Yes, indicated in site plan.
 - B. **Will trees be required along dedicated streets UDO Article 151.156?** N/A
24. **Findings Regarding Additional Requirements:**
 - A. **Endangering the public health and safety:** If ingress/egress is proposed off Ponderosa road, staff feels that with the width of Ponderosa Road and current road conditions, proposed use will have a severe impact on the public health and safety. Road is currently utilized by another mining operation (Camden Yard Materials) and have received several complaints from residential property owners stating the dump trucks are tearing up the road to a point that they claim is not drivable. Erosion is severe at each culvert pipe crossing the road.
 - B. **Injure the value of adjoining or abutting property:** The application does not appear to injure the value of adjoining or abutting property.
 - C. **Harmony with the area in which it is located:** Yes, property zoned for commercial development, however staff feels unless an alternative access other than Ponderosa road is provided the proposed use is affect the harmony of the residents to utilize their property as residential.
 - D. **Conformity with the Plans:**

UDO2007-05-15
Mining Operation
Page 2 of 5

BOOK 253 PAGE 499

1. **Land Use Plan:** Area consistent with the county's future land use map. However, Article 151.034 of the Unified Development Ordinance, states that "mining operations should be located in very limited locations".
 2. **Thoroughfare Plan:** Only access to site is off Ponderosa Road (Private ROW).
 3. **Other plans officially adopted by the Board of Commissioners:**
None
- E. Will not exceed the county's ability to provide public facilities:**
1. **Schools:** Proposed development will have no impact on schools.
 2. **Fire and Rescue:** During heavy rain events, road condition could prevent access by Fire and Rescue vehicles.
 3. **Law Enforcement:** During heavy rain events, road condition could prevent access by Law Enforcement vehicles.
- Other County Facilities:** None.
- F. Other:** None.

Approved by the Board of Commissioners on August 6, 2007 vote with the following conditions:

1. The applicant must strictly abide by all requirements of the Unified Development Ordinance of Camden County, North Carolina, and must also strictly comply with all other local, state, and federal ordinances, laws, rules and regulations as one or more ordinances, laws, rules and regulations may apply to this development.
2. The applicant shall complete the development strictly in accordance with the plans approved by the Board of Commissioners of Camden County, North Carolina, and contained in the file titled UDO 2007-05-15.
3. Applicant shall aid in maintaining the upkeep of Ponderosa Road to current conditions.
4. Prior to any land disturbing activity, applicant shall provide an Erosion and Sedimentation Control Plan approved by the North Carolina Department and Environmental and Natural Resources (DENR).
5. Prior to any land disturbing activity, applicant shall provide the Planning Office a copy of the Mining Permit approved by DENR.
6. Applicant shall retain the cut over trees that lay within the buffer area indicated on site plans.
7. Hours of Operations shall be April 1 – October 31, 7:00 AM – 6:00 PM, Monday thru Friday; November 1 – March 31, 7:00 AM – 5:00 PM, Monday thru Friday.
8. If any of the conditions affixed hereto or any part thereof shall be held invalid or void, then this approval in its entirety shall be void and have no effect.

IN WITNESS WHEREOF, the County has caused this Special Use Permit to be issued in its name, and the undersigned, being all of the property owners/applicants of the property above described, do hereby accept this special use permit together with all its conditions as binding on them, their successors and their assigns in interest.

UDO2007-05-15
Mining Operation
Page 3 of 5

BOOK 253 PAGE 500

I, Gary Meiggs, owner of the above-identified property do hereby acknowledge receipt of this Order authorizing the issuance of a Special Use Permit. The undersigned owner/applicant does further acknowledge that no work may be done pursuant to the Permit except in accordance with all of its conditions and requirements and that all restrictions shall be binding upon them, their assigns, and their successors in interest.

Dawn Meiggs
Gary Meiggs Applicant/Property Owner

Date: 8-7-07

NORTH CAROLINA
CAMDEN COUNTY

I, Dawn W. Forbes, a Notary Public in and for said state and county, do hereby certify that Gary Meiggs Applicant/Property owner, personally appeared before me this day and acknowledged the due execution of the foregoing instrument.

WITNESS my hand and notarial seal the 7 day of August, 2007.

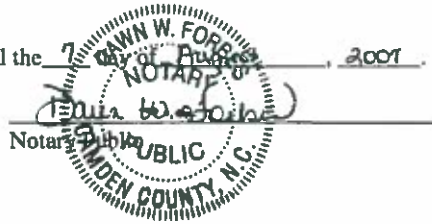

My commission expires: 7/20/08

COUNTY OF CAMDEN

ATTEST:

I, David A. Parks, Permit Officer for Camden County, do hereby acknowledge receipt of this Order authorizing the issuance of a Special Use Permit. The undersigned individual does further acknowledge that no work may be done pursuant to the Permit except in accordance with all of its conditions and requirements and that all restrictions shall be binding upon them, their assigns and their successors in interest.

David A. Parks
David A. Parks, Permit Officer

UDO2007-05-15
Mining Operation
Page 4 of 5



North Carolina Department of Environment and Natural Resources
 Division of Land Resources
 Land Quality Section

James D. Simons, PG, PE
 Director and State Geologist

Beverly Eaves Perdue, Governor
 Dee Freeman, Secretary

July 15, 2010

Mr. Bonney G. Bright
 5513 Buzzard Neck Road
 Virginia Beach, Virginia 23457

Re: Meiggs Tract Mine
 Camden County
 Pasquotank River Basin

Dear Mr. Bright:

The application for a mining permit for the above referenced mine site has been found to meet the requirements of G.S. 74-51 of The Mining Act of 1971. As we have received the required security to cover this application, I am enclosing the mining permit.

The conditions of Mining Permit No. 15-12 were based primarily upon information supplied in the application with conditions added as necessary to insure compliance with The Mining Act of 1971. This permit expires on July 15, 2020. G.S. 74-65 states that the issuance of a mining permit does not supersede or otherwise affect or prevent the enforcement of any zoning regulation or ordinance duly adopted by an incorporated city or county or by any agency or department of the State of North Carolina.

As a reminder, your permitted acreage at this site is 113.89 acres and the amount of land you are approved to disturb is 102.0 acres.

Please review the permit and contact Ms. Judy Wehner, Assistant State Mining Specialist, at (919) 733-4574 of any objection or questions concerning the terms of the permit.

Sincerely,

Francis M. Nevils, Jr., PE
 Section Chief

FMN/jw

Enclosures: Permit No. 15-12
 Notice of Issuance

cc: Mr. Pat McClain, PE
 Ms. Shannon Deaton -WRC, w/permit
 Mr. William Gerringier-DOL, Mine and Quarry Bureau, w/o enclosures
 US Fish and Wildlife Service, w/ permit

1612 Mail Service Center, Raleigh, North Carolina 27699-1612 • Telephone 919-733-4574 / FAX: 919-733-2676
 512 North Salisbury Street, Raleigh, North Carolina, 27604 • Internet <http://www.dnr.enr.state.nc.us/pages/landqualitysection.html>
 An Equal Opportunity / Affirmative Action Employer - 50% Recycled / 10% Post Consumer Paper

DEPARTMENT OF ENVIRONMENT
AND NATURAL RESOURCES
DIVISION OF LAND RESOURCES
LAND QUALITY SECTION

P E R M I T

for the operation of a mining activity

In accordance with the provisions of G.S. 74-46 through 68, "The Mining Act of 1971," Mining Permit Rule 15A NCAC 5 B, and other applicable laws, rules and regulations

Permission is hereby granted to:

Bonney G. Bright

Meiggs Tract Mine

Camden County - Permit No. 15-12

for the operation of a

Sand Mine

which shall provide that the usefulness, productivity and scenic values of all lands and waters affected by this mining operation will receive the greatest practical degree of protection and restoration.

MINING PERMIT EXPIRATION DATE July 15, 2020

In accordance with the application for this mining permit, which is hereby approved by the Department of Environment and Natural Resources, hereinafter referred to as the Department, and in conformity with the approved Reclamation Plan attached to and incorporated as part of this permit, provisions must be made for the protection of the surrounding environment and for reclamation of the land and water affected by the permitted mining operation. This permit is expressly conditioned upon compliance with all the requirements of the approved Reclamation Plan. However, completed performance of the approved Reclamation Plan is a separable obligation, secured by the bond or other security on file with the Department, and may survive the expiration, revocation or suspension of this permit.

This permit is not transferable by the permittee with the following exception: If another operator succeeds to the interest of the permittee in the permitted mining operation, by virtue of a sale, lease, assignment or otherwise, the Department may release the permittee from the duties imposed upon him by the conditions of his permit and by the Mining Act with reference to the permitted operation, and transfer the permit to the successor operator, provided that both operators have complied with the requirements of the Mining Act and that the successor operator agrees to assume the duties of the permittee with reference to reclamation of the affected land and posts a suitable bond or other security.

In the event that the Department determines that the permittee or permittee's successor is not complying with the Reclamation Plan or other terms and conditions of this permit, or is failing to achieve the purposes and requirements of the Mining Act, the Department may give the operator written notice of its intent to modify, revoke or suspend the permit, or its intent to modify the Reclamation Plan as incorporated in the permit. The operator shall have right to a hearing at a designated time and place on any proposed modification, revocation or suspension by the Department. Alternatively and in addition to the above, the Department may institute other enforcement procedures authorized by law.

Definitions

Wherever used or referred to in this permit, unless the context clearly indicates otherwise, terms shall have the same meaning as supplied by the Mining Act, N.C.G.S. 74-49.

Expiration Date

This permit shall be effective from the date of its issuance until July 15, 2020.

Conditions

This permit shall be subject to the provisions of the Mining Act, N.C.G.S. 74-46, et. seq., and to the following conditions and limitations:

OPERATING CONDITIONS:

1. A. Any wastewater processing or mine dewatering shall be in accordance with the permitting requirements and rules promulgated by the N.C. Environmental Management Commission.

- B. Any stormwater runoff from the affected areas at the site shall be in accordance with any applicable permit requirements and regulations promulgated by the Environmental Protection Agency and enforced by the N.C. Environmental Management Commission. It shall be the permittee's responsibility to contact the Division of Water Quality to secure any necessary stormwater permits or other approval documents.
2.
 - A. Any mining process producing air contamination emissions shall be subject to the permitting requirements and rules promulgated by the N.C. Environmental Management Commission and enforced by the Division of Air Quality.
 - B. During mining operations, water trucks or other means that may be necessary shall be utilized to prevent dust from leaving the permitted area.
 3.
 - A. Sufficient buffer (minimum 50 foot undisturbed) shall be maintained between any affected land and any adjoining waterway or wetland to prevent sedimentation of that waterway or wetland from erosion of the affected land and to preserve the integrity of the natural watercourse or wetland.
 - B. Any mining activity affecting waters of the State, waters of the U. S., or wetlands shall be in accordance with the requirements and regulations promulgated and enforced by the N. C. Environmental Management Commission.
 - C. No dewatering activities at the site or discharges from the site shall occur until proof has been submitted to the Division of Land Resources that an NPDES permit has been issued from the Division of Water Quality.
 4.
 - A. Adequate mechanical barriers including but not limited to diversions, earthen dikes, silt check dams, silt retarding structures, rip rap pits, or ditches shall be provided in the initial stages of any land disturbance and maintained to prevent sediment from discharging onto adjacent surface areas or into any lake, wetland or natural watercourse in proximity to the affected land.
 - B. All drainage from the affected area around the mine excavation shall be diverted internal to said excavation or into the approved sediment and erosion control measures.
 - C. Mining activities shall occur as indicated on the Mine Development/Reclamation Plan Map last revised May 8, 2009 and the supplemental information received by the Land Quality Section on March 2, 2009, August 28, 2009, December 17, 2009 and March 19, 2010.

5. Groundwater monitoring wells shall be installed and monitored as deemed appropriate by the Department as follows:
 - A. Monitoring wells shall be installed as specified in the "Adjacent Well Survey and Ground Water Monitoring Plan" last revised April 2010 and monitored at least bimonthly (twice per month) beginning 90 days prior to initiating any land disturbing activities at the site (other than the land disturbing activities needed to install the monitoring wells and the approved erosion and sedimentation control measures) to allow for the determination of pre-existing (static) groundwater levels and parameter levels. In addition, neighboring wells shall be monitored at least monthly 90 days prior to initiating any excavation. The operator shall notify the Department once all the monitoring wells are installed.
 - B. The well depths shall be as proposed in the "Adjacent Well Survey and Ground Water Monitoring Plan" last revised April 2010 and received on April 26, 2010.
 - C. The monitoring wells shall be drilled wells screened at the base depth of the excavation (the ultimate depth of the mine). The wells shall be secured against unauthorized entry with a lockable cap. The necessary permits or approvals to construct these wells shall be obtained from the N.C. Division of Water Quality, Groundwater Section.
 - D. The monitoring wells shall be monitored bimonthly (twice per month) at the same day and approximate time of day. The static water levels shall be measured with an accuracy of plus or minus 0.1 foot and shall be referenced to a datum point and a record of the water levels maintained. The bimonthly precipitation and the volume of pit water discharge shall also be recorded. Copies of these records shall be provided to the Department on or about the end of each month. Static water level monitoring frequency may be increased or decreased as deemed appropriate by the Department.
 - E. Any water supply wells affected by the mining operation shall be replaced by the operator.
6. All permit boundaries (113.89 acres) shall be permanently marked at the site on 100-foot intervals unless the line of sight allows for larger spacing intervals.
7. The angle for graded slopes and fills shall be no greater than the angle, which can be retained by vegetative cover or other adequate erosion control measure, structure, or device. In any event, exposed slopes or any excavated channels, the erosion of which may cause off-site damage because of siltation, shall be planted or otherwise provided with ground cover, devices or structures sufficient to restrain such erosion.
8. The affected land shall be graded so as to prevent collection of pools of water that are, or likely to become, noxious or foul. Necessary structures such as drainage ditches or conduits shall be constructed or installed when required to prevent such conditions.

9. Existing vegetation or vegetated earthen berms shall be maintained between the mine and public thoroughfares whenever practical to screen the operation from the public.
10.
 - A. Sufficient buffer shall be maintained between any excavation and any mining permit boundary to protect adjacent property.
 - B. All buffers shall be maintained as indicated on the Mine Development/Reclamation Plan Map last revised May 8, 2009
11.
 - A. No on-site disposal of refuse or other solid waste that is generated outside of the mining permit area shall be allowed within the boundaries of the mining permit area unless authorization to conduct said disposal has first been obtained from both the Division of Waste Management and the Land Quality Section, Department of Environment and Natural Resources. The method of disposal shall be consistent with the approved reclamation plan.
 - B. Mining refuse as defined by G.S. 74-49 (14) of The Mining Act of 1971 generated on-site and directly associated with the mining activity may be disposed of in a designated refuse area. All other waste products must be disposed of in a disposal facility approved by the Division of Waste Management. No petroleum products, acids, solvents or their storage containers or any other material that may be considered hazardous shall be disposed of within the permitted area.
 - C. For the purposes of this permit, the Division of Land Resources considers the following materials to be "mining refuse" (in addition to those specifically listed under G.S. 74-49 (14) of the N.C. Mining Act of 1971):
 1. on-site generated land clearing debris
 2. conveyor belts
 3. wire cables
 4. v-belts
 5. steel reinforced air hoses
 6. drill steel
 - D. If mining refuse is to be permanently disposed within the mining permit boundary, the following information must be provided to and approved by the Division of Land Resources prior to commencement of such disposal:
 1. the approximate boundaries and size of the refuse disposal area;
 2. a list of refuse items to be disposed;
 3. verification that a minimum of 4 feet of cover will be provided over the refuse;
 4. verification that the refuse will be disposed at least 4 feet above the seasonally high water table; and,
 5. verification that a permanent vegetative groundcover will be established.

12. An Annual Reclamation Report shall be submitted on a form supplied by the Department by February 1 of each year until reclamation is completed and approved.
13. The operator shall notify the Department in writing of the desire to delete, modify or otherwise change any part of the mining, reclamation, or erosion/sediment control plan contained in the approved application for a mining permit or any approved revision to it. Approval to implement such changes must be obtained from the Department prior to on-site implementation of the revisions.
14. The security, which was posted pursuant to N.C.G.S. 74-54 in the form of a \$79,500.00 Irrevocable Standby Letter of Credit, is sufficient to cover the operation as indicated in the approved application. This security must remain in force for this permit to be valid. The total affected land shall not exceed the bonded acreage.
15.
 - A. Authorized representatives of the Division of Archives and History shall be granted access to the site to determine the presence of significant archaeological resources.
 - B. Pursuant to N. C. G. S. 70 Article 3, "The Unmarked Human Burial and Human Skeletal Remains Protection Act," should the operator or any person in his employ encounter human skeletal remains, immediate notification shall be provided to the county medical examiner and the chief archaeologist, North Carolina Division of Archives and History.

APPROVED RECLAMATION PLAN

The Mining Permit incorporates this Reclamation Plan, the performance of which is a condition on the continuing validity of that Mining Permit. Additionally, the Reclamation Plan is a separable obligation of the permittee, which continues beyond the terms of the Mining Permit.

The approved plan provides:

Minimum Standards As Provided By G.S. 74-53

1. The final slopes in all excavations in soil, sand, gravel and other unconsolidated materials shall be at such an angle as to minimize the possibility of slides and be consistent with the future use of the land.
2. Provisions for safety to persons and to adjoining property must be provided in all excavations in rock.
3. All overburden and spoil shall be left in a configuration which is in accordance with accepted conservation practices and which is suitable for the proposed subsequent use of the land.
4. No small pools of water shall be allowed to collect or remain on the mined area that are, or are likely to become noxious, odious or foul.
5. The revegetation plan shall conform to accepted and recommended agronomic and reforestation practices as established by the North Carolina Agricultural Experiment Station and the North Carolina Forest Service.
6. Permittee shall conduct reclamation activities pursuant to the Reclamation Plan herein incorporated. These activities shall be conducted according to the time schedule included in the plan, which shall to the extent feasible provide reclamation simultaneous with mining operations and in any event, provide reclamation at the earliest practicable time after completion or termination of mining on any segment of the permit area and shall be completed within two years after completion or termination of mining.

RECLAMATION CONDITIONS:

1. Provided further, and subject to the Reclamation schedule, the planned reclamation shall be to restore the mine excavation to a lake area and to grade and revegetate the adjacent disturbed areas.
2. The specifications for surface gradient restoration to a surface suitable for the planned future use are as follows:
 - A. The lake area shall be excavated to maintain a minimum water depth of four feet measured from the low water table elevation.

- B. The side slopes to the lake excavation shall be graded to a 3 horizontal to 1 vertical or flatter to the water line and 2 horizontal to 1 vertical or flatter below the water line.
- C. Any areas used for wastepiles, screening, stockpiling or other processing shall be leveled and smoothed.
- D. No contaminants shall be permanently disposed of at the mine site. On-site disposal of waste shall be in accordance with Operating Condition Nos. 10A through 10D.
- E. The affected land shall be graded to prevent the collection of noxious or foul water.

3. Revegetation Plan:

After site preparation, all disturbed land areas shall be revegetated as per the Revegetation Plan approved by Mr. Dwane Hinson, District Conservationist with the Albemarle Soil and Water Conservation District on June 4, 2007.

Whenever possible, disturbed areas should be vegetated with native warm season grasses such as switch grass, Indian grass, bluestem and gamma grass.

In addition, the permittee shall consult with a professional wildlife biologist with the N.C. Wildlife Resources Commission to enhance post-project wildlife habitat at the site.

4. Reclamation Plan:

Reclamation shall be conducted simultaneously with mining to the extent feasible. In any event, reclamation shall be initiated as soon as feasible after completion or termination of mining of any mine segment under permit. Final reclamation, including revegetation, shall be completed within two years of completion or termination of mining.

Permit issued this 15th day of July, 2010.

By: 

James D. Simons, Director
Division of Land Resources
By Authority of the Secretary
Of the Department of Environment and Natural Resources

NOTICE OF ISSUANCE OF
MINING PERMIT

You have previously expressed an interest and/or are listed as an adjoining landowner in the application for a mining permit filed by Bonney G. Bright to conduct mining activities off US Highway 17 in Camden County. The mining permit (no. 15-12) was issued on July 15, 2010.

North Carolina law allows persons aggrieved by the issuance of a mining permit to contest the decision by filing a petition for a contested case in the Office of Administrative Hearings pursuant to N.C.G.S. 150B-23 of the Administrative Procedure Act (APA).

If you believe that you are an aggrieved party within the meaning of the APA, a petition for a contested case must be filed in the Office of Administrative Hearings within sixty (60) days of the mailing of this notice to you.

If you file a contested case petition, it must be in writing and in the form prescribed by N.C. General Statutes 150B-23. File the original petition and one copy with the Office of Administrative Hearings, 6714 Mail Service Center, Raleigh, NC 27699-6714.

Any questions about filing a petition may be directed to the Clerk of the Office of Administrative Hearings by telephoning (919) 733-0926.

You must serve the **Department of Environment and Natural Resources** by mailing a copy of the petition to Ms. Mary Penny Thompson, Registered Agent and General Counsel, Department of Environment and Natural Resources, 1601 Mail Service Center, Raleigh, NC 27699-1601.



James D. Simons
Director
Division of Land Resources
North Carolina Department of
Environment and Natural
Resources

This notice was mailed on 7/17/2010



Brenda Harris
Mining Program Secretary

**U.S. ARMY CORPS OF ENGINEERS
WILMINGTON DISTRICT**

Action Id. SAW-2011-01138 County: Camden U.S.G.S. Quad: VA-LAKE DRUMMOND SE

GENERAL PERMIT (REGIONAL AND NATIONWIDE) VERIFICATION

Permittee: B&M Investments, LLC.
Bonnev Bright
Address: 5563 Buzzards Neck Road
Virginia Beach, VA, 23457

Telephone Number: (757)721-5823

Size (acres) 113.89
Nearest Waterway Dismal Swamp Canal-ICW
USGS HUC 03010205

Nearest Town South Mills
River Basin Pasquotank
Coordinates Latitude: 36.548001
Longitude: -76.321851

Location description: The project is located on an approximately 115 acres east of US17 on Ponderosa Drive near the town of South Mills, in Camden County, North Carolina.

Description of projects area and activity: Project will involve the mining of an undeveloped upland parcel and the installation of a dewatering outfall structure within the waters of the US.

Applicable Law: Section 404 (Clean Water Act, 33 USC 1344)
 Section 10 (Rivers and Harbors Act, 33 USC 403)

Authorization: Regional General Permit Number or Nationwide Permit Number: NWP 7 , NWP 13
SEE ATTACHED RGP or NWP GENERAL, REGIONAL AND SPECIAL CONDITIONS

Your work is authorized by the above referenced permit provided it is accomplished in strict accordance with the attached conditions and your submitted application and attached information dated July 28, 2016. Any violation of the attached conditions or deviation from your submitted plans may subject the permittee to a stop work order, a restoration order, a Class I administrative penalty, and/or appropriate legal action.

This verification will remain valid until the expiration date identified below unless the nationwide authorization is modified, suspended or revoked. If, prior to the expiration date identified below, the nationwide permit authorization is reissued and/or modified, this verification will remain valid until the expiration date identified below, provided it complies with all requirements of the modified nationwide permit. If the nationwide permit authorization expires or is suspended, revoked, or is modified, such that the activity would no longer comply with the terms and conditions of the nationwide permit, activities which have commenced (i.e., are under construction) or are under contract to commence in reliance upon the nationwide permit, will remain authorized provided the activity is completed within twelve months of the date of the nationwide permit's expiration, modification or revocation, unless discretionary authority has been exercised on a case-by-case basis to modify, suspend or revoke the authorization.

Activities subject to Section 404 (as indicated above) may also require an individual Section 401 Water Quality Certification. You should contact the NC Division of Water Quality (telephone 919-807-6300) to determine Section 401 requirements.

For activities occurring within the twenty coastal counties subject to regulation under the Coastal Area Management Act (CAMA), prior to beginning work you must contact the N.C. Division of Coastal Management in Elizabeth City, NC, at (252) 264-3901.

This Department of the Army verification does not relieve the permittee of the responsibility to obtain any other required Federal, State or local approvals/permits.

If there are any questions regarding this verification, any of the conditions of the Permit, or the Corps of Engineers regulatory program, please contact Krvstynka Stvgar at 910-251-4619 or Krvstynka.B.Stvgar@usace.army.mil.

Corps Regulatory Official: _____ Date: July 28, 2016
Expiration Date of Verification: March 18, 2017

SAW-2011-01138

Determination of Jurisdiction:

- A. Based on preliminary information, there appear to be waters of the US including wetlands within the above described project area. This preliminary determination is not an appealable action under the Regulatory Program Administrative Appeal Process (Reference 33 CFR Part 331).
- B. There are Navigable Waters of the United States within the above described project area subject to the permit requirements of Section 10 of the Rivers and Harbors Act and Section 404 of the Clean Water Act. Unless there is a change in the law or our published regulations, this determination may be relied upon for a period not to exceed five years from the date of this notification.
- C. There are waters of the US and/or wetlands within the above described project area subject to the permit requirements of Section 404 of the Clean Water Act (CWA)(33 USC § 1344). Unless there is a change in the law or our published regulations, this determination may be relied upon for a period not to exceed five years from the date of this notification.
- D. The jurisdictional areas within the above described project area have been identified under a previous action. Please reference jurisdictional determination issued August 1, 2011. Action ID: SAW-2011-01138.

Basis for Determination: This site exhibits wetland criteria as defined in the 1987 Corps Wetland Delineation Manual and appropriate Regional Supplement.

Remarks:

E. Attention USDA Program Participants

This delineation/determination has been conducted to identify the limits of Corps' Clean Water Act jurisdiction for the particular site identified in this request. The delineation/determination may not be valid for the wetland conservation provisions of the Food Security Act of 1985. If you or your tenant are USDA Program participants, or anticipate participation in USDA programs, you should request a certified wetland determination from the local office of the Natural Resources Conservation Service, prior to starting work.

F. Appeals Information (This information applies only to approved jurisdictional determinations as indicated in B and C above).

This correspondence constitutes an approved jurisdictional determination for the above described site. If you object to this determination, you may request an administrative appeal under Corps regulations at 33 CFR Part 331. Enclosed you will find a Notification of Appeal Process (NAP) fact sheet and request for appeal (RFA) form. If you request to appeal this determination you must submit a completed RFA form to the following address:

US Army Corps of Engineers
South Atlantic Division
Attn: Jason Steele, Review Officer
60 Forsyth Street SW, Room 10M15
Atlanta, Georgia 30303-8801
Phone: (404) 562-5137

In order for an RFA to be accepted by the Corps, the Corps must determine that it is complete, that it meets the criteria for appeal under 33 CFR part 331.5, and that it has been received by the Division Office within 60 days of the date of the NAP. Should you decide to submit an RFA form, it must be received at the above address by September 20, 2016.

It is not necessary to submit an RFA form to the Division Office if you do not object to the determination in this correspondence.

Corps Regulatory Official: _____
Krystynka Stygar

Date of JD: July 22, 2016

Expiration Date of JD: July 22, 2021

SAW-2011-01138

The Wilmington District is committed to providing the highest level of support to the public. To help us ensure we continue to do so, please complete our customer Satisfaction Survey online at <http://regulatory.usacesurvey.com/>.

Copy furnished:

Agent: Harold Jones
Sigma Environmental Services, Inc.
Address: 1513 Sandbridge Road
Virginia Beach, VA, 23456
Telephone Number: (757)615-9974

Action ID Number: SAW-2011-01138 County: Camden

Permittee: B&M Investments, LLC.
Bonney Bright

Project Name: Bright-Meiggs Tract/Camden/JD

Date Verification Issued: July 22, 2016

Project Manager: Krystynka Stygar

Upon completion of the activity authorized by this permit and any mitigation required by the permit, sign this certification and return it to the following address:

US ARMY CORPS OF ENGINEERS
WILMINGTON DISTRICT
Washington Field Office
2407 West 5th Street
Washington, NC 27889
Attn: Krystynka Stygar

Please note that your permitted activity is subject to a compliance inspection by a U. S. Army Corps of Engineers representative. Failure to comply with any terms or conditions of this authorization may result in the Corps suspending, modifying or revoking the authorization and/or issuing a Class I administrative penalty, or initiating other appropriate legal action.

I hereby certify that the work authorized by the above referenced permit has been completed in accordance with the terms and condition of the said permit, and required mitigation was completed in accordance with the permit conditions.

Signature of Permittee

Date

**NOTIFICATION OF ADMINISTRATIVE APPEAL OPTIONS AND PROCESS AND
REQUEST FOR APPEAL**

Applicant: **B&M Investments, LLC.
Bonney Bright**

File Number: **SAW-2011-01138**

Date: **July 28, 2016**

Attached is:

See Section below

<input type="checkbox"/>	INITIAL PROFFERED PERMIT (Standard Permit or Letter of permission)	A
<input type="checkbox"/>	PROFFERED PERMIT (Standard Permit or Letter of permission)	B
<input type="checkbox"/>	PERMIT DENIAL	C
<input checked="" type="checkbox"/>	APPROVED JURISDICTIONAL DETERMINATION	D
<input type="checkbox"/>	PRELIMINARY JURISDICTIONAL DETERMINATION	E

SECTION I - The following identifies your rights and options regarding an administrative appeal of the above decision. Additional information may be found at or <http://www.usace.army.mil/Missions/CivilWorks/RegulatoryProgramandPermits.aspx> or the Corps regulations at 33 CFR Part 331.

A: INITIAL PROFFERED PERMIT: You may accept or object to the permit.

- **ACCEPT:** If you received a Standard Permit, you may sign the permit document and return it to the district engineer for final authorization. If you received a Letter of Permission (LOP), you may accept the LOP and your work is authorized. Your signature on the Standard Permit or acceptance of the LOP means that you accept the permit in its entirety, and waive all rights to appeal the permit, including its terms and conditions, and approved jurisdictional determinations associated with the permit.
- **OBJECT:** If you object to the permit (Standard or LOP) because of certain terms and conditions therein, you may request that the permit be modified accordingly. You must complete Section II of this form and return the form to the district engineer. Your objections must be received by the district engineer within 60 days of the date of this notice, or you will forfeit your right to appeal the permit in the future. Upon receipt of your letter, the district engineer will evaluate your objections and may: (a) modify the permit to address all of your concerns, (b) modify the permit to address some of your objections, or (c) not modify the permit having determined that the permit should be issued as previously written. After evaluating your objections, the district engineer will send you a proffered permit for your reconsideration, as indicated in Section B below.

B: PROFFERED PERMIT: You may accept or appeal the permit

- **ACCEPT:** If you received a Standard Permit, you may sign the permit document and return it to the district engineer for final authorization. If you received a Letter of Permission (LOP), you may accept the LOP and your work is authorized. Your signature on the Standard Permit or acceptance of the LOP means that you accept the permit in its entirety, and waive all rights to appeal the permit, including its terms and conditions, and approved jurisdictional determinations associated with the permit.
- **APPEAL:** If you choose to decline the proffered permit (Standard or LOP) because of certain terms and conditions therein, you may appeal the declined permit under the Corps of Engineers Administrative Appeal Process by completing Section II of this form and sending the form to the division engineer. This form must be received by the division engineer within 60 days of the date of this notice.

C: PERMIT DENIAL: You may appeal the denial of a permit under the Corps of Engineers Administrative Appeal Process by completing Section II of this form and sending the form to the division engineer. This form must be received by the division engineer within 60 days of the date of this notice.

D: APPROVED JURISDICTIONAL DETERMINATION: You may accept or appeal the approved JD or provide new information.

- **ACCEPT:** You do not need to notify the Corps to accept an approved JD. Failure to notify the Corps within 60 days of date of this notice, means that you accept the approved JD in its entirety, and waive all rights to appeal the approved JD.
- **APPEAL:** If you disagree with the approved JD, you may appeal the approved JD under the Corps of Engineers Administrative Appeal Process by completing Section II of this form and sending the form to the district engineer. This form must be received by the division engineer within 60 days of the date of this notice.

E: PRELIMINARY JURISDICTIONAL DETERMINATION: You do not need to respond to the Corps regarding the preliminary JD. The Preliminary JD is not appealable. If you wish, you may request an approved JD (which may be appealed), by contacting the Corps district for further instruction. Also you may provide new information for further consideration by the Corps to reevaluate the JD.

SECTION II - REQUEST FOR APPEAL or OBJECTIONS TO AN INITIAL PROFFERED PERMIT

REASONS FOR APPEAL OR OBJECTIONS: (Describe your reasons for appealing the decision or your objections to an initial proffered permit in clear concise statements. You may attach additional information to this form to clarify where your reasons or objections are addressed in the administrative record.)

ADDITIONAL INFORMATION: The appeal is limited to a review of the administrative record, the Corps memorandum for the record of the appeal conference or meeting, and any supplemental information that the review officer has determined is needed to clarify the administrative record. Neither the appellant nor the Corps may add new information or analyses to the record. However, you may provide additional information to clarify the location of information that is already in the administrative record.

POINT OF CONTACT FOR QUESTIONS OR INFORMATION:

If you have questions regarding this decision and/or the appeal process you may contact:
District Engineer, Wilmington Regulatory Division, Attn: Krystynka Stygar

If you only have questions regarding the appeal process you may also contact:
Mr. Jason Steele, Administrative Appeal Review Officer
CESAD-PDO
 U.S. Army Corps of Engineers, South Atlantic Division
 60 Forsyth Street, Room 10M15
 Atlanta, Georgia 30303-8801
 Phone: (404) 562-5137

RIGHT OF ENTRY: Your signature below grants the right of entry to Corps of Engineers personnel, and any government consultants, to conduct investigations of the project site during the course of the appeal process. You will be provided a 15 day notice of any site investigation, and will have the opportunity to participate in all site investigations.

Signature of appellant or agent.	Date:	Telephone number:
----------------------------------	-------	-------------------

For appeals on Initial Proffered Permits send this form to:

District Engineer, Wilmington Regulatory Division, Attn: Krystynka Stygar, 2407 West 5th Street, Washington, NC 27889

For Permit denials, Proffered Permits and approved Jurisdictional Determinations send this form to:

Division Engineer, Commander, U.S. Army Engineer Division, South Atlantic, Attn: Mr. Jason Steele, Administrative Appeal Officer, CESAD-PDO, 60 Forsyth Street, Room 10M15, Atlanta, Georgia 30303-8801
Phone: (404) 562-5137

Σ SIGMA ENVIRONMENTAL SERVICES, Inc.

July 19, 2016

Ms. Krystynka B. Styger
Regulatory Branch
US Army Corps of Engineers
Washington Regional Office
2407 W. 5th Street
Washington, North Carolina 27889

**Subject: Request for Wetland Determination/Delineation Re-Confirmation and
Jurisdictional Determination**

Dear Ms. Styger:

Pursuant to our field discussions and your follow-up email, enclosed please find a completed Jurisdictional Request Form and a 11 x 17 inch map of the subject site.

If you need any additional information to complete your re-confirmation of wetland delineation and Notification of Jurisdictional Determination, please do not hesitate to contact by email at: rharoldjones@aol.com, phone: 757 615-9974, or the letterhead address.

Thank you in advance for your efforts on this request.

Sincerely,

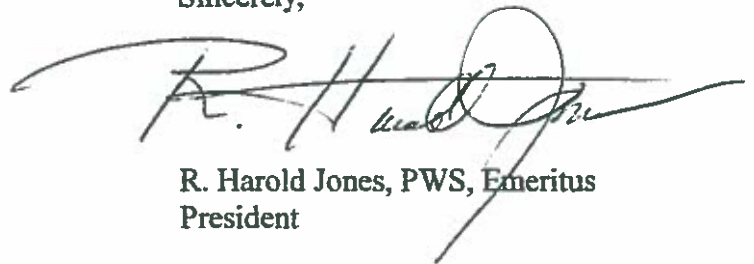

R. Harold Jones, PWS, Emeritus
President

Bonney G. Bright, Co-Owner
Enclosures

1513 SANDBRIDGE ROAD, VIRGINIA BEACH, VIRGINIA 23456
Business Cell (757) 615-9974. FAX (757) 426-5145. Email: Rharoldjones@aol.com

Jurisdictional Determination Request

A. PARCEL INFORMATION

Street Address: PONDEROSA DRIVE
 City, State: SOUTH MILLS, NC
 County: CAMDEN
 Directions: FROM INTERSECTION OF US RT 17 HEADING NORTH - TURN RIGHT ON PONDEROSA DRIVE AND TRAVEL 2.7 MILES - SITE LOCATED ON LEFT (NORTH SIDE) OF THE ROAD
 Parcel Index Number(s) (PIN): 01-7082-00-68-8936-0000

B. REQUESTOR INFORMATION

Name: R. HAROLD JONES, PWS, EMERITUS
 Mailing Address: 1513 SAND BRIDGE RD, VA BEACH, VA
 Telephone Number: 757-615-9974 23456
 Electronic Mail Address¹: R.HAROLDJONES@AOL.COM

Select one:

- I am the current property owner.
- I am an Authorized Agent or Environmental Consultant²
- Interested Buyer or Under Contract to Purchase
- Other, please explain.

C. PROPERTY OWNER INFORMATION

Name: BONNEY B. BRIGHT
 Mailing Address: 5513 BUZZARD NECK RD. VIRGINIA BEACH, VA 23457
 Telephone Number: 757-721-5823
 Electronic Mail Address³: — —

Proof of Ownership Attached (e.g. a copy of Deed, County GIS/Parcel/Tax Record data)
D.B. 247, P.6.35; PB-6, SL-28
SOUTH MILLS TOWNSHIP

¹ If available

² Must attach completed Agent Authorization Form

³ If available

Jurisdictional Determination Request

D. PROPERTY OWNER CERTIFICATION⁴

I, the undersigned, a duly authorized owner of record of the property/properties identified herein, do authorize representatives of the Wilmington District, U.S. Army Corps of Engineers (Corps) to enter upon the property herein described for the purpose of conducting on-site investigations and issuing a determination associated with Waters of the U.S. subject to Federal jurisdiction under Section 404 of the Clean Water Act and/or Section 10 of the Rivers and Harbors Act of 1899.

BOHNEY G. BRIGHT
Property Owner (please print)

7-18-2016
Date

Bonney G. Bright
Property Owner Signature

E. JURISDICTIONAL DETERMINATION TYPE

Select One:

- I am requesting that the Corps provide a preliminary JD for the property identified herein. This request does include a delineation.
- I am requesting that the Corps provide a preliminary JD for the property identified herein. This request does NOT include a delineation.
- I am requesting that the Corps investigate the property/project area for the presence or absence of WoUS⁵ and provide an approved JD for the property identified herein. This request does NOT include a request for a verified delineation.
- I am requesting that the Corps delineate the boundaries of all WoUS on a property/project area and provide an approved JD (this may or may not include a survey plat).
- I am requesting that the Corps evaluate and approve a delineation of WoUS (conducted by others) on a property/project area and provide an approved JD (may or may not include a survey plat).

⁴ For NCDOT requests following the current NCDOT/USACE protocols, skip to Part E.

⁵ Waters of the United States

Jurisdictional Determination Request

F. ALL REQUESTS

- Map of Property or Project Area (attached). This Map must clearly depict the boundaries of the area of evaluation.
- Size of Property or Project Area 113.89 acres
- I verify that the property (or project) boundaries have recently been surveyed and marked by a licensed land surveyor OR are otherwise clearly marked or distinguishable.

G. JD REQUESTS FROM CONSULTANTS OR AGENCIES

(1) Preliminary JD Requests:

- Completed and signed Preliminary Jurisdictional Determination Form⁶.
- Project Coordinates: _____ Latitude _____ Longitude

Maps (no larger than 11x17) with Project Boundary Overlay:

- Large and small scale maps that depict, at minimum: streets, intersections, towns
- Aerial Photography of the project area
- USGS Topographic Map
- Soil Survey Map
- Other Maps, as appropriate (e.g. National Wetland Inventory Map, Proposed Site Plan, previous delineation maps, LIDAR maps, FEMA floodplain maps)

⁶ See Appendix A of this Form. From Regulatory Guidance Letter No. 08-02, dated June 26, 2008

Jurisdictional Determination Request

Delineation Information (when applicable)⁷:

Wetlands:

Wetland Data Sheets⁸

Upland Data Sheets

Landscape Photos, if taken

Field Sketch overlain on legible Map that includes:

- All aquatic resources (for sites with multiple resources, label and identify)
- Locations of wetland data points and/or tributary assessment reaches
- Locations of photo stations
- Approximate acreage/linear footage of aquatic resources

Tributaries:

USACE Assessment Forms

Other Assessment Forms
(when appropriate)

(2) Approved JDs including Verification of a Delineation:

Project Coordinates: 36.54505³ Latitude 76.323⁴ Longitude

Maps (no larger than 11x17) with Project Boundary Overlay:

Large and small scale maps that depict, at minimum: streets, intersections, towns

Aerial Photography of the project area

USGS Topographic Map

Soil Survey Map

Other Maps, as appropriate (e.g. National Wetland Inventory Map, Proposed Site Plan, previous delineation maps)

⁷ 1987 Manual Regional Supplements and Data forms can be found at:

http://www.usace.army.mil/Missions/CivilWorks/RegulatoryProgramandPermits/reg_supp.aspx

Wetland and Stream Assessment Methodologies can be found at:

http://portal.nceenr.org/c/document_library/get_file?uuid=76f3c58b-dab8-4960-ba43-45b7faf06f4c&groupId=38364 and,

http://www.saw.usace.army.mil/Portals/59/docs/regulatory/publicnotices/2013/NCSAM_Draft_User_Manual_130318.pdf

⁸ Delineation information must include, at minimum, one wetland data sheet for each wetland/community type.

Jurisdictional Determination Request

Delineation Information (when applicable):

Wetlands:

Wetland Data Sheets⁹

Upland Data Sheets

Landscape Photos, if taken

Field Sketch overlain on legible Map that includes:

- All aquatic resources (for sites with multiple resources, label and identify)
- Locations of wetland data points and/or tributary assessment reaches
- Locations of photo stations
- Approximate acreage/linear footage of aquatic resources

Tributaries:

USACE Assessment Forms

Other Assessment Forms
(when appropriate)

Supporting Jurisdictional Information (for Approved JDs only)

Approved Jurisdictional Determination Form(s) (also known as “Rapanos Form(s)”)

Map(s) depicting the potential (or lack of potential) hydrologic connection(s), adjacency, etc. to navigable waters.

⁹ Delineation information must include, at minimum, one wetland data sheet for each wetland/community type.

Jurisdictional Determination Request

I. REQUESTS FOR CORPS APPROVAL OF SURVEY PLAT

Prior to final production of a Plat, the Wilmington District recommends that the Land Surveyor electronically submit a draft of a Survey Plat to the Corps project manager for review.

Due to storage limitations of our administrative records, the Corps requires that all hard-copy submittals include at least one original Plat (to scale) that is no larger than 11"x17" (the use of match lines for larger tracts acceptable). Additional copies of a plat, including those larger than 11"x17", may also be submitted for Corps signature as needed. The Corps also accepts electronic submittals of plats, such as those transmitted as a Portable Document Format (PDF) file. Upon verification, the Corps can electronically sign these plats and return them via e-mail to the requestor.

(1) PLATS SUBMITTED FOR APPROVAL

- Must be sealed and signed by a licensed professional land surveyor
- Must be to scale (all maps must include both a graphic scale and a verbal scale)
- Must be legible
- Must include a North Arrow, Scale(s), Title, Property Information
- Must include a legible WoUS Delineation Table of distances and bearings/metres and bounds/GPS coordinates of all surveyed delineation points
- Must clearly depict surveyed property or project boundaries
- Must clearly identify the known surveyed point(s) used as reference (e.g. property corner, USGS monument)
- When wetlands are depicted:
 - Must include acreage (or square footage) of wetland polygons
 - Must identify each wetland polygon using an alphanumeric system

Jurisdictional Determination Request

- When tributaries are depicted:
- Must include either a surveyed, approximate centerline of tributary with approximate width of tributary OR surveyed Ordinary High Water Marks (OHWM) of tributary
 - Must identify each tributary using an alphanumeric system
 - Must include linear footage of tributaries and calculated area (using approximate widths or surveyed OHWM)
 - Must include name of tributary (based on the most recent USGS topographic map) or, when no USGS name exists, identify as “unnamed tributary”
- all depicted WoUS (wetland polygons and tributary lines) must intersect or tie-to surveyed project/property boundaries
- Must include the location of wetland data points and/or tributary assessment reaches
- Must include, label accordingly, and depict acreage of all waters not currently subject to the requirements of the CWA (e.g. “isolated wetlands”, “non-jurisdictional waters”). NOTE: An approved JD must be conducted in order to make an official Corps determination that a particular waterbody or wetland is not jurisdictional.
- Must include and survey all existing conveyances (pipes, culverts, etc.) that transport WoUS

Jurisdictional Determination Request

(2) CERTIFICATION LANGUAGE

When the entire actual Jurisdictional Boundary is depicted:

include the following Corps Certification language:

"This certifies that this copy of this plat accurately depicts the boundary of the jurisdiction of Section 404 of the Clean Water Act as determined by the undersigned on this date. Unless there is a change in the law or our published regulations, the determination of Section 404 jurisdiction may be relied upon for a period not to exceed five (5) years from this date. The undersigned completed this determination utilizing the appropriate Regional Supplement to the 1987 U.S. Army Corps of Engineers Wetlands Delineation Manual."

Regulatory Official: _____

Title: _____

Date: _____

USACE Action ID No.: _____

When uplands may be present within a depicted Jurisdictional Boundary:

include the following Corps Certification language:

"This certifies that this copy of this plat identifies all areas of waters of the United States regulated pursuant to Section 404 of the Clean Water Act as determined by the undersigned on this date. Unless there is change in the law or our published regulations, this determination of Section 404 jurisdiction may be relied upon for a period not to exceed five years from this date. The undersigned completed this determination utilizing the appropriate Regional Supplement to the 1987 U.S. Army Corps of Engineers Wetlands Delineation Manual."

Regulatory Official: _____

Title: _____

Date: _____

USACE Action ID No.: _____

Jurisdictional Determination Request

(3) GPS SURVEYS

For Surveys prepared using a Global Positioning System (GPS), the Survey must include all of the above, as well as:

- be at sub-meter accuracy at each survey point.
- include an accuracy verification:
One or more known points (property corner, monument) shall be located with the GPS and cross-referenced with the existing traditional property survey (metes and bounds).
- include a brief description of the GPS equipment utilized.

MINING DEVELOPMENT PLAN FOR BRIGHT MINE - MEIGGS TRACT SOUTH MILLS TOWNSHIP CAMDEN COUNTY NORTH CAROLINA

OWNER/MANAGER/DEVELOPER: BONNEY G. BRIGHT
5513 BUZZARD NECK RD.
VIRGINIA BEACH, VA 23457
757-721-5823 (Office)

ENGINEER: Bissell Professional Group
Mark S. Bissell, P.E.
P.O. Box 1068
Kitty Hawk, N.C. 27949
(252) 261-3265
fax: (252) 261-1760
email: m_rmark@bissellprofessionalgroup.com

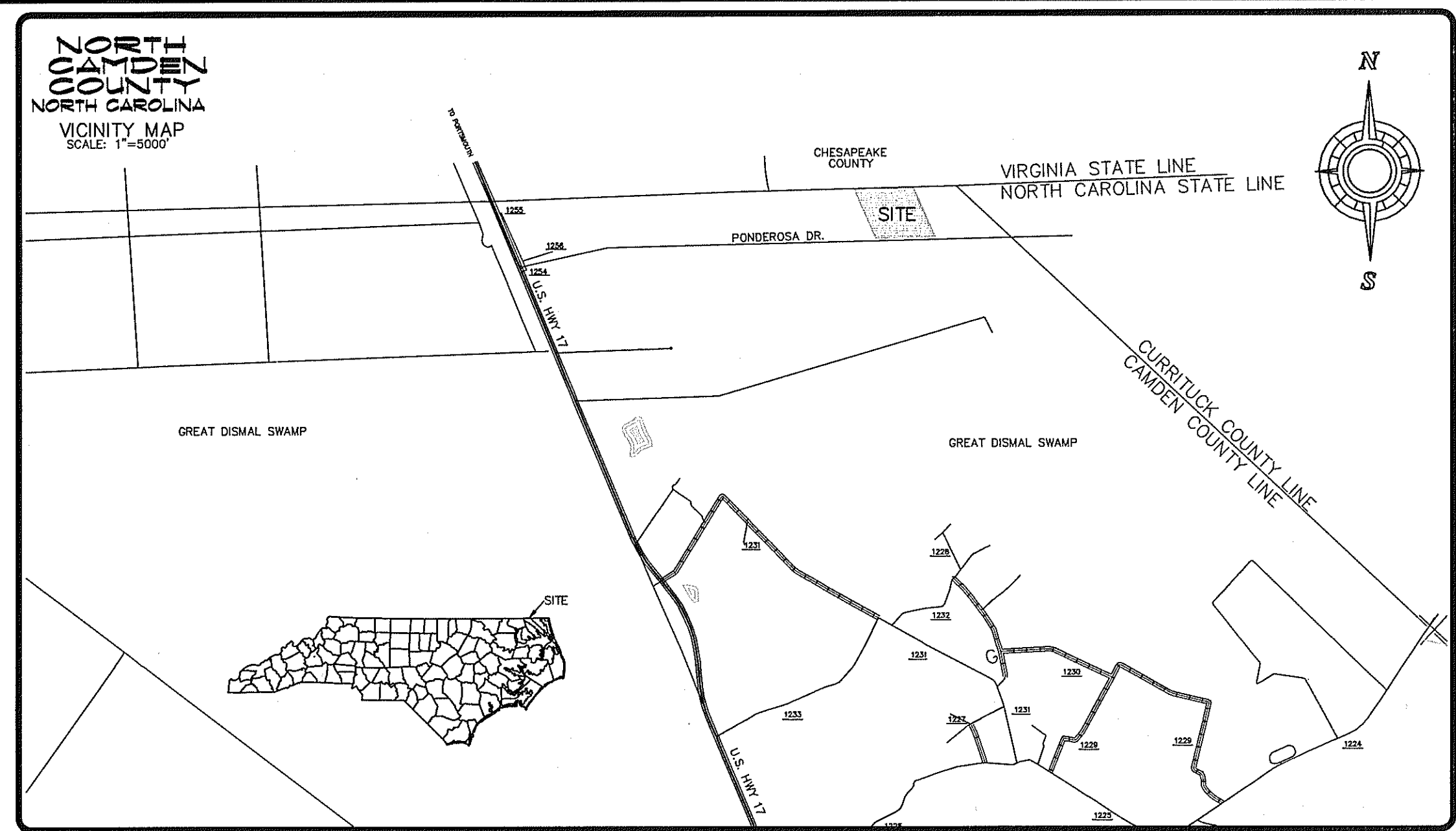

- NOTES:**
- DEVELOPER/MANAGER: B & M INVESTMENTS OF NORTH CAROLINA, LLC
5015 BUZZARD NECK RD
VIRGINIA BEACH, VA 23457
757-721-5823 (Office)
 - SUBJECT PROPERTY: A 113.89 AC. TRACT OF LAND LOCATED ALONG THE NORTH SIDE OF PONDEROSA DR. APPROX 2.7 MILES EAST OF US HWY 17 AT THE VIRGINIA/NORTH CAROLINA BORDER. P.N.# 01-7082-00-66-9936-0000 AS RECORDED: D.B.241, PG.35, PB.6, SL. 28 SOUTH MILLS TOWNSHIP, CAMDEN COUNTY, NORTH CAROLINA.
- SUBJECT PARCEL BOUNDARIES BASED ON "RECOMBINATION PLAT DRAWN FOR W.E. MEIGGS & SON LOGGING COMPANY, INC." PREPARED BY SCOTT L. TEMPLE, L-3768, DATED 3-15-07, PROJECT # 2007-047, P.B. 6, SL. 28, CAMDEN COUNTY. ADJOINING PARCEL BOUNDARIES BASED ON THE FOLLOWING REFERENCES RECORDED W/ CAMDEN COUNTY REGISTER OF DEEDS: "SAVNER STATE LINE FARM", PREPARED BY ANDREW W. PEARCE, L-729, DATED 10-22-1979, PB. 72, PG. 6-A; "CHARLES A. & MARY L. ROBERTS", PREPARED BY S. ELMO WILLIAMS, L-609, DATED 3-31-1993, PG. 2, SL. 48-B; "REMOVE PARCEL BOUNDARIES BASED ON READING MATTER", PREPARED BY J. GARY CULP, L-2950, DATED 9-27-2001, PG. 3, SL. 100-B; CAMDEN COUNTY, NC - GPS CONTROL SYSTEM FOR REFERENCE ONLY, ACCURACY IS NOT GUARANTEED. TOPOGRAPHIC INFORMATION BASED ON N.C.D.O.T. CONTOURS & SURVEY BY BISSELL PROFESSIONAL GROUP ON 4-18-2007.
 - TOTAL PARCEL AREA : 4,961,104 SQ. FT. (113.89 AC.)
 - SITE ZONING : I-1, LIGHT INDUSTRIAL (TO BE REZONED W/ MINING OVERLAY DISTRICT)
 - LAND USE - EXISTING USE: AGRICULTURAL (14.100)
PROPOSED USE: MINING QUARRY OPERATIONS (14.200)

TRACT DEVELOPMENT SUMMARY:

ENTRANCE, PARKING, & OFFICE AREA = 13,000 SQ. FT. (0.30 AC.)
STOCKPILE/PROCESSING AREA = 175,981 SQ. FT. (4.04 AC.)
PROPOSED HAUL ROAD = 216,768 SQ. FT. (5.02 AC.)
PROPOSED SETTLING POND AREA = 5,484 SQ. FT. (0.22 AC.)
PROPOSED EXCAVATED AREA = 3,821,133 SQ. FT. (80.02 AC.)
PROPOSED MISC. DISTURBED AREA = 210,454 SQ. FT. (4.83 AC.)
EXISTING GRAVEL ROAD AREA = 68,660 SQ. FT. (1.57 AC.)
TOTAL AFFECTED AREA = 4,617,360 S.F. (106 AC.)
% MINING COVERAGE OF PARCEL (EXCAVATION ONLY) = 79.0%

 - TOTAL PERMITTED AREA : 5,070,821 SQ. FT. (116.4 AC.)
 - BUFFER YARD REQUIREMENTS:
PROPOSED LAND USE: MINING & QUARRY OPERATIONS (14.200)

ADJONER	ADJACENT USE	BUFFER
NORTH	AGRICULTURAL	TYPE "B"
EAST	AGRICULTURAL (14.100)	TYPE "B"
SOUTH	PRIVATE R/W	TYPE "A"
WEST	SINGLE FAMILY (1.100)	TYPE "A"

TYPE "A" BUFFER - OPAQUE - LANDSCAPING THAT IS OPAQUE FROM THE GROUND TO A HEIGHT OF 6', W/ INTERMITTENT VISUAL OBSTRUCTION FROM ABOVE THE OPAQUE PORTION TO A HEIGHT OF AT LEAST 20'. AN OPAQUE LANDSCAPING IS INTENDED TO COMPLETELY ALL VISUAL CONTACT BETWEEN USES AND TO CREATE A STRONG IMPRESSION OF SPATIAL SEPARATION.

TYPE "B" BUFFER - SEMI-OPAQUE - LANDSCAPING THAT IS 50% OPAQUE FROM THE GROUND TO A HEIGHT OF 3', W/ INTERMITTENT VISUAL OBSTRUCTION FROM ABOVE THE OPAQUE PORTION TO A HEIGHT OF AT LEAST 20'. THE SEMI-OPAQUE LANDSCAPING IS INTENDED TO PARTIALLY BLOCK VISUAL CONTACT BETWEEN USES AND TO CREATE A STRONG IMPRESSION OF THE SEPARATION OF SPACES.

 - BASED UPON AERIAL PHOTOGRAPHY, TOPOGRAPHY, SURROUNDING DRAINAGE MEASURES, AND THE HISTORICAL USE OF THE LAND IT HAS BEEN ASSUMED THAT THERE ARE NO WELLS LOCATED ON SITE.
 - FEMA DATA: FIRM PANEL 370042 7083 CAMDEN COUNTY, NORTH CAROLINA, ADOPTED 12/16/05. ALL PROPOSED DEVELOPMENT WITHIN ZONE X (FLOOD ZONES SUBJECT TO CHANGE BY FEMA) USE OF LAND WITHIN A SPECIAL FLOOD HAZARD AREA IS SUBSTANTIALLY RESTRICTED BY SECTIONS 191.200 - 191.397 OF THE CAMDEN COUNTY ZONING ORDINANCE.
 - WHERE TWO OR MORE ACCESSES TO THE MINING OPERATION EXIST, TRAFFIC SHALL BE ROUTED TO THE ACCESS HAVING THE LEAST NEGATIVE IMPACT ON ADJOINING PROPERTIES.
 - MINE MATERIALS SHALL NOT BE STORED IN EXCESS OF TWENTY-FIVE (25) FEET IN HEIGHT.
 - ALL TRUCKS HAULING MINED MATERIAL, (I.E. SAND, CLAY, TOPSOIL) SHALL BE COVERED WITH A TARPULAIN.
 - NO BULK WASTE, HAZARDOUS WASTE, COMMERCIAL WASTE, GARBAGE, CONSTRUCTION OR DEMOLITION WASTE SHALL BE PLACED ON SITE.
 - NO TRESPASSING SIGNS SHALL BE POSTED AROUND THE SITE BEING MINED AT A MINIMUM DISTANCE OF 250' APART INDICATING THAT A MINING OPERATION IS BEING CONDUCTED ON THE PROPERTY.
 - DRAINAGE PATTERNS SHALL NOT BE ALTERED AS TO CAUSE FLOODING OFF-SITE WHILE THE PERMIT IS VALID AND AFTER RECLAMATION.
 - NO MINING ACTIVITIES SHALL ADVERSELY AFFECT SURROUNDING IN USE WELLS. ANY PERSON OWNING OR OPERATING A MINING SITE IN A MANNER THAT ADVERSELY AFFECTS AN IN USE WELL THROUGH CONTAMINATION OR DIMINUTION OF GROUNDWATER SHALL PROVIDE THE WELL OWNER WITH A REPLACEMENT WATER SUPPLY OF EQUAL QUANTITY & QUALITY.
 - APPLICANT WILL MAKE AVAILABLE ANY POND AREAS TO THE LOCAL VOLUNTEER FIRE DEPARTMENT FOR INSTALLATION OF A DRY HYDRANT, IF REQUESTED BY THE LOCAL VFD. ALL ASSOCIATED COSTS FOR INSTALLATION WILL BE THE RESPONSIBILITY OF THE LOCAL VFD.

THE MINING OPERATION CONSISTS OF A 102 ACRE MINE FOR THE EXCAVATION AND DISTRIBUTION OF SAND. THE SITE IS LOCATED OFF OF (US HWY. 17) WITHIN THE SOUTH MILLS TOWNSHIP OF CAMDEN COUNTY, NORTH CAROLINA. THE FOLLOWING DESCRIBES THE OPERATIONAL SUMMARY OF THE PROPOSED OPERATION:

OPERATION SUMMARY:

- THE ANTICIPATED AVERAGE DAILY TRAFFIC LOAD COUNT IS 100 LOADS, WITH ONE TRUCK LEAVING APPROXIMATELY EVERY SIX MINUTES. AN OCCASIONAL LARGE JOB WILL INCREASE THE TRAFFIC LOAD TO APPROXIMATELY 200 LOADS PER DAY, WITH ONE TRUCK LEAVING EVERY THREE MINUTES.
- THE EXCAVATOR WILL EITHER TEMPORARILY STOCKPILE MATERIAL IN THOSE AREAS SPECIFIED OR PLACE THE MATERIAL DIRECTLY INTO DUMP TRUCKS WHICH WILL HAUL MATERIAL TO OTHER LOCATIONS WITHIN THE PROPOSED MINING AREA.
- LOADING OF SAND ON DELIVERY DUMP TRUCKS WILL BE DONE BY A RUBBER TIRE FRONT-END LOADER AND AN EXCAVATOR OPERATING AT THE MINING AREA ENTRANCE.
- TRUCKS ENTERING THE MINING AREA WILL BE REQUIRED TO STOP AT THE OFFICE TRAILER TO RECEIVE LOAD TICKETS AND INSTRUCTIONS UPON ENTERING AND EXITING THE MINING AREA. SPEED LIMITS WILL BE POSTED ALONG ROAD TO THE MINING AREA AND WILL BE STRICTLY ENFORCED. ALL TRUCKS EXITING THE SITE WITH MINED MATERIAL SHALL BE COVERED WITH A TARPULAIN.
- A DEWATERING PUMP WILL BE PROVIDED TO LOWER THE STATIC GROUND WATER TABLE AS MINING PROGRESSES. DISCHARGE FROM THE PUMP WILL BE DIRECTED TO A PROPOSED SETTLING BASIN LOCATED ADJACENT TO THE ENTRANCE OF THE MINE. THIS SETTLING BASIN IS PROVIDED TO REDUCE THE AMOUNT OF SUSPENDED SOLID GROUNDWATER PRIOR TO BEING RELEASED INTO THE ADJOINING CANAL LOCATED ALONG THE SOUTH SIDE OF PONDEROSA DR. THIS CANAL IS LINKED TO SEVERAL OTHER EXISTING DRAINAGE CANALS IN THE AREA AND IS DIRECTLY CONNECTED TO THE DISMAL SWAMP CANAL LOCATED ALONG THE WEST SIDE OF US HWY 17. THE DISMAL SWAMP CANAL SERVES AS A PORTION OF THE INTERCOASTAL WATERWAY AND IS CLASSIFIED AS C, SW.
- A MOTOR GRADER WILL BE PROVIDED AND OPERATED TO MAINTAIN THE MINE'S ENTRANCE ROAD AND PORTIONS OF THE EXISTING PONDEROSA DR. GRAVEL ROAD AS DEEMED NECESSARY.
- IT IS PROJECTED THAT THE NUMBER OF EMPLOYEES OPERATING AT THIS FACILITY WILL BE 15.
- THE HOURS OF OPERATION OF ALL MINING RELATED FACILITIES AND ACTIVITIES ON THE MINING SITE SHALL BE ESTABLISHED BY THE CAMDEN COUNTY BOARD OF COMMISSIONERS. IN NO CASE SHALL THE HOURS OF OPERATION BE BEYOND DAWN TO DUSK NOR SHALL MINING ACTIVITY OCCUR ON SUNDAYS.

CONSTRUCTION SEQUENCE:

THE MINING OPERATION WILL CONSIST OF ENTRANCE, HAUL ROAD, & SETTLING BASIN CONSTRUCTION. STRIPPING OF OVERBURDEN, EXCAVATION, AND DEWATERING OF THE MINING AREA. EXCESS MINE MATERIAL WILL BE STOCKPILED IN THE DESIGNATED SITE AREA FOR TRANSPORT FOR OFF-SITE USE. RESTORED AREAS UNAFFECTED BY THE DAILY MINING OPERATION WILL BE ESTABLISHED WITH A VEGETATIVE COVER WITHIN 21 DAYS OF DISTURBANCE. THE DURATION OF THE MINING OPERATION IS ANTICIPATED TO LAST FOR APPROXIMATELY 10 YEARS AT WHICH TIME RECLAMATION WILL TAKE PLACE.

RECLAMATION SUMMARY:

WHEN POSSIBLE, RECLAMATION SHALL BE CONDUCTED SIMULTANEOUSLY WITH THE MINING OPERATIONS. ANNUAL RECLAMATION REPORTS SHALL BE SUBMITTED TO THE PLANNING & INSPECTORS DEPARTMENT WITHIN 10 DAYS OF STATE SUBMISSION.

THE BULK OF THE RECLAMATION WILL COMMENCE UPON THE COMPLETION OF THE MINING OPERATION, OR AT THE END OF A 10-15 YEAR PERIOD. THE EXCAVATED MINING AREA WILL BE UTILIZED AS A FUTURE LAKE FOR AGRICULTURAL AND RECREATIONAL PURPOSES. ALL STOCKPILE, OVERBURDEN, & SETTLING BASIN AREAS WILL BE GRADED LEVEL AND STABILIZED W/ PERMANENT VEGETATION. THE HAUL ROAD WILL BE KEPT INTACT TO PROVIDE FUTURE LAKE ACCESS. RECLAMATION WILL PROCEED AT THE COMPLETION OF THE OPERATION WITHOUT ANY PROVISIONS FOR STAGING OF RECLAMATION.

AT COMPLETION OF RECLAMATION, IT IS ANTICIPATED THAT THE PROPERTY WILL REMAIN UNDER CURRENT OWNERSHIP ASSUMING RESPONSIBILITY FOR ANY ON-SITE ENVIRONMENTAL POLLUTION THAT MAY OCCUR AFTER EXCAVATION ACTIVITIES ARE COMPLETE.

LEGEND

These standard symbols will be found in the drawing.

—○—	POWER POLE
—	RIGHT-OF-WAY
—+—	EXISTING GRADE CONTOUR
—	C/L OF ROAD
---	EDGE OF PAVEMENT/GRAVEL
---	PROPOSED TOP OF SLOPE/TOE OF SLOPE
---	PROPOSED WATER SURFACE
---	MINE OVERLAY DISTRICT/DISTURBANCE LIMITS
---	EXISTING TREELINE
---	EXISTING DRAINAGE
---	PROPOSED CULVERT (SIZE AS DENOTED)
---	PERMIT BOUNDARY LIMITS
---	PROPOSED SEDIMENT FENCE
○	EXISTING PRIVATE WATER SUPPLY WELL
○	PROPOSED GRAVEL ENTRANCE
○	PROPOSED HAUL RD.
○	PROPOSED STOCKPILE AREA
○	EXISTING GRAVEL RD. (PONDEROSA DR.)
○	EXISTING CANAL/LAKE WATER SURFACE
○	EXISTING VEGETATIVE SCREEN

SHEET INDEX

SHEET	DESCRIPTION
1	SITE LOCATION OVERVIEW
2	MINE DEVELOPMENT/RECLAMATION PLAN
3	CONSTRUCTION DETAILS

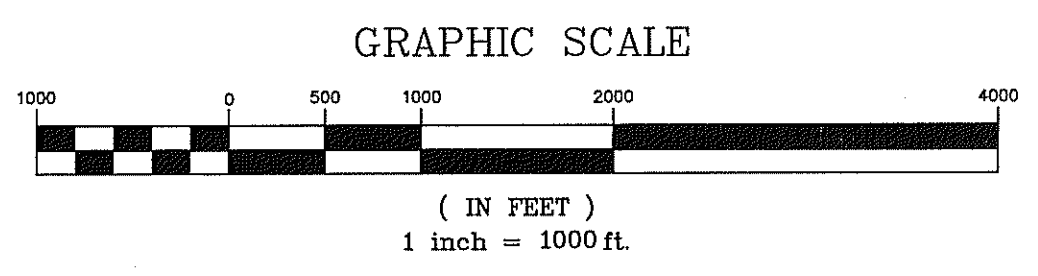
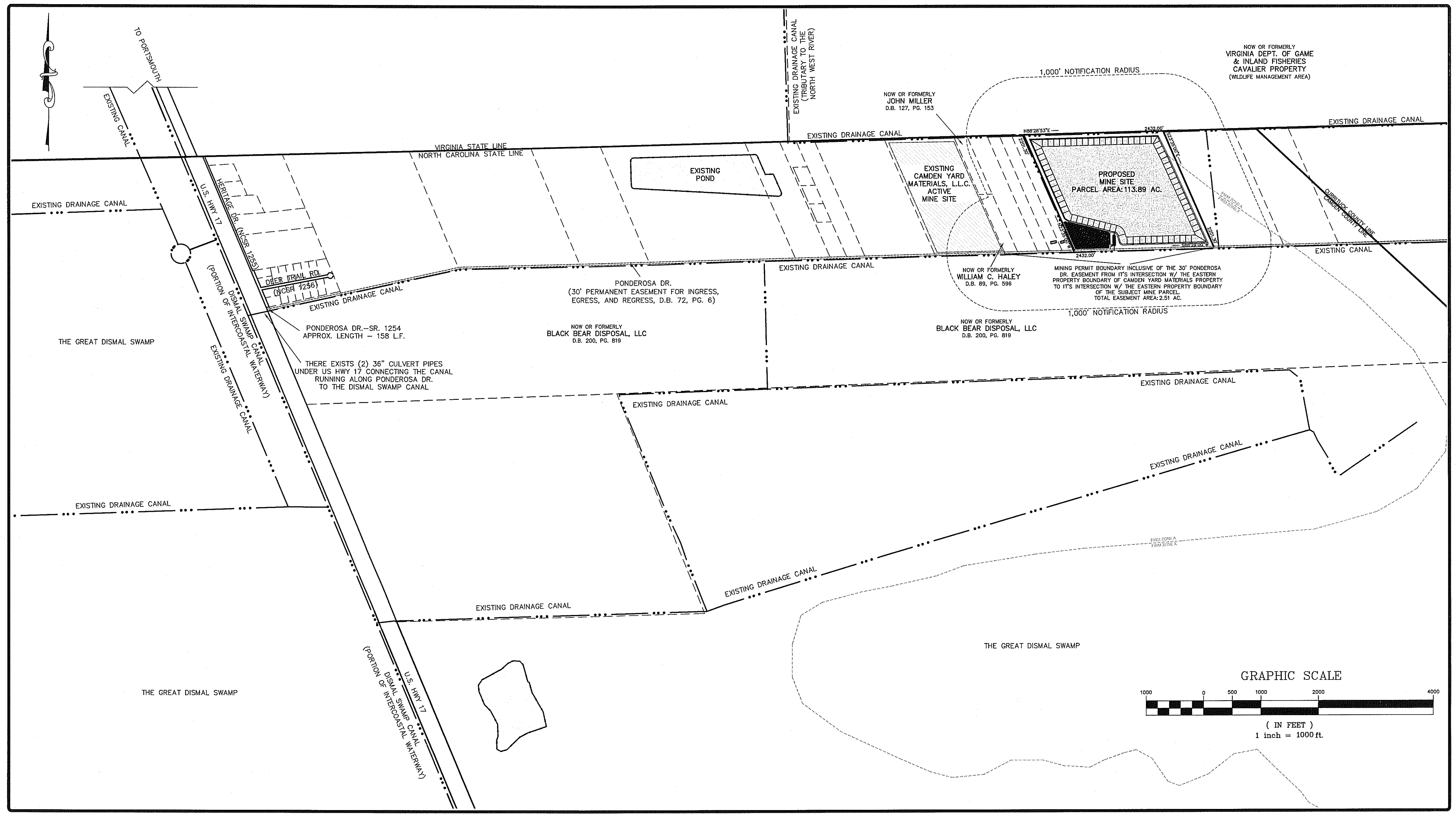

Bissell Professional Group
10000 Old Dominion Highway
P.O. Box 1068
Kitty Hawk, North Carolina 27949
FAX (252) 261-1760

BISSELL PROFESSIONAL GROUP
Engineers, Planners, Surveyors
and Environmental Specialists

SITE LOCATION OVERVIEW

THIS DOCUMENT IS THE SOLE PROPERTY OF BPG, INC. OF KITTY HAWK, NORTH CAROLINA. THE REPRODUCTION, IN WHOLE OR IN PART, OF THIS DOCUMENT WITHOUT THE EXPRESS WRITTEN CONSENT OF BPG, INC. IS PROHIBITED. BISSSELL, PRINCIPAL OF BPG, INC. COPYRIGHT © 2005.

BRIGHT MINE - MEIGGS TRACT

MINE DEVELOPMENT/RECLAMATION PLAN

NORTH CAROLINA
CAMDEN
SOUTH MILLS TOWNSHIP

PROJECT NO.: 435800M1

REVISIONS

NO.	DATE	DESCRIPTION	BY	CHK
1	7/2/2010	INITIAL DESIGN	DMK	MSB
2	7/2/2010	REVISED PER STATE COMMENTS	DMK	MSB
3	7/2/2010	REVISED PER STATE COMMENTS	DMK	MSB

APPROVED

DATE: 7/2/2010

SCALE: 1" = 1000'

CREATED: BPG
DRAWN: DMK
CHECKED: MSB
APPROVED: MSB

SHEET: 1 OF 3

CAD FILE: 435800M1

PROJECT NO: 4358

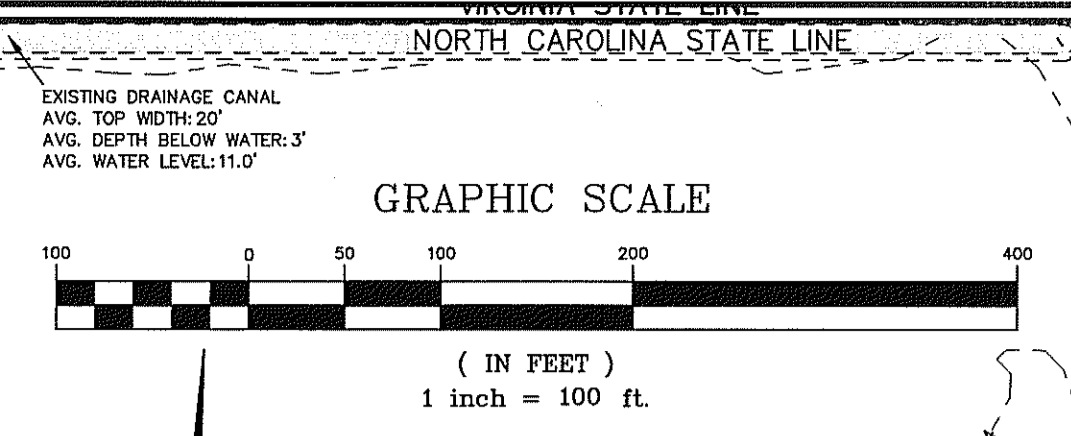
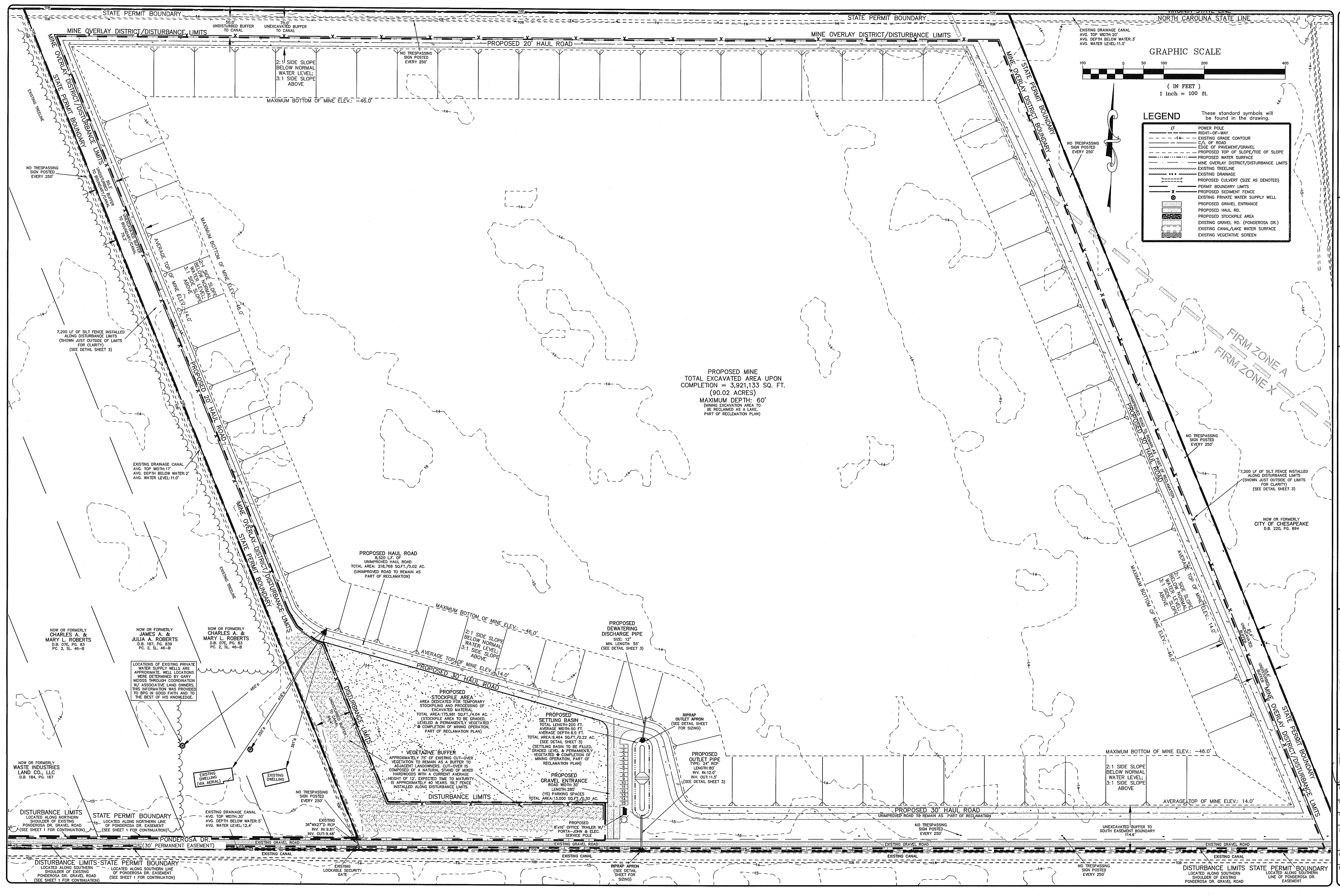

LEGEND

These standard symbols will be found in the drawing.

—P—	POWER POLE
—R—	RIGHT-OF-WAY
—E—	EXISTING GRADE CONTOUR
—C—	C/L OF ROAD
—P—	EDGE OF PAVEMENT/GRAVEL
—T—	PROPOSED TOP OF SLOPE/TOE OF SLOPE
—W—	PROPOSED WATER SURFACE
—M—	MINE OVERLAY DISTRICT/DISTURBANCE LIMITS
—T—	EXISTING TREETLINE
—D—	EXISTING DRAINAGE
—C—	PROPOSED CULVERT (SIZE AS DENOTED)
—B—	PERMIT BOUNDARY LIMITS
—X—	PROPOSED SEDIMENT FENCE
—W—	EXISTING PRIVATE WATER SUPPLY WELL
—E—	PROPOSED GRAVEL ENTRANCE
—H—	PROPOSED HAIL RD.
—S—	PROPOSED STOCKPILE AREA
—G—	EXISTING GRAVEL RD. (PONDEROSA DR.)
—W—	EXISTING CANAL/LAKE WATER SURFACE
—V—	EXISTING VEGETATIVE SCREEN

PROPOSED MINE
TOTAL EXCAVATED AREA UPON
COMPLETION = 3,921,133 SQ. FT.
(90.02 ACRES)
MAXIMUM DEPTH: 60'
(MINING EXCAVATION AREA TO
BE RECLAIMED AS A LAKE,
PART OF RECLAMATION PLAN)

Bissell Professional Group
302 North Graham Highway
Kitty Hawk, North Carolina 27949
TEL: (252) 261-1760
FAX: (252) 261-1760

BISSELL
PROFESSIONAL GROUP

Engineers, Planners, Surveyors
and Environmental Specialists

MINING PLAN
RECLAMATION PLAN

THIS DOCUMENT IS THE SOLE PROPERTY OF BRG, INC. OF KITTY HAWK, NORTH CAROLINA. THE REPRODUCTION, IN WHOLE OR IN PART, OF THIS DOCUMENT WITHOUT THE EXPRESS WRITTEN CONSENT OF BRG, INC. IS PROHIBITED.
BISSELL, PRINCIPAL OF BRG, INC., COPYRIGHT 2005.

BRIGHT MINE - MEIGGS TRACT
NORTH CAROLINA
CAMDEN
SOUTH MILLS TOWNSHIP

MINE DEVELOPMENT/RECLAMATION PLAN

NO.	DATE	DESCRIPTION	BY	CHKD.
1	12/14/07	ISSUED FOR PERMIT	DMK	DMK
2	1/17/07	REVISED TO ADD SILT FENCE & BUFFER TOE OF SLOPE	DMK	DMK
3	1/27/07	REVISED TO ADD EXISTING DRAINAGE	DMK	DMK
4	2/1/07	REVISED TO ADD SILT FENCE & BUFFER TOE OF SLOPE	DMK	DMK
5	2/1/07	REVISED TO ADD SILT FENCE & BUFFER TOE OF SLOPE	DMK	DMK
6	2/1/07	REVISED TO ADD SILT FENCE & BUFFER TOE OF SLOPE	DMK	DMK
7	2/1/07	REVISED TO ADD SILT FENCE & BUFFER TOE OF SLOPE	DMK	DMK
8	2/1/07	REVISED TO ADD SILT FENCE & BUFFER TOE OF SLOPE	DMK	DMK
9	2/1/07	REVISED TO ADD SILT FENCE & BUFFER TOE OF SLOPE	DMK	DMK
10	2/1/07	REVISED TO ADD SILT FENCE & BUFFER TOE OF SLOPE	DMK	DMK
11	2/1/07	REVISED TO ADD SILT FENCE & BUFFER TOE OF SLOPE	DMK	DMK
12	2/1/07	REVISED TO ADD SILT FENCE & BUFFER TOE OF SLOPE	DMK	DMK
13	2/1/07	REVISED TO ADD SILT FENCE & BUFFER TOE OF SLOPE	DMK	DMK
14	2/1/07	REVISED TO ADD SILT FENCE & BUFFER TOE OF SLOPE	DMK	DMK
15	2/1/07	REVISED TO ADD SILT FENCE & BUFFER TOE OF SLOPE	DMK	DMK
16	2/1/07	REVISED TO ADD SILT FENCE & BUFFER TOE OF SLOPE	DMK	DMK
17	2/1/07	REVISED TO ADD SILT FENCE & BUFFER TOE OF SLOPE	DMK	DMK
18	2/1/07	REVISED TO ADD SILT FENCE & BUFFER TOE OF SLOPE	DMK	DMK
19	2/1/07	REVISED TO ADD SILT FENCE & BUFFER TOE OF SLOPE	DMK	DMK
20	2/1/07	REVISED TO ADD SILT FENCE & BUFFER TOE OF SLOPE	DMK	DMK

DATE: 03-07-07 SCALE: 1"=100'

DESIGNED: BPG CHECKED: MSB

DRAWN: DMK APPROVED: MSB

SHEET: 2 OF 3

CAD FILE: 435800M1

PROJECT NO.: 4358

NOTES:
 1) THOSE AREAS, AS DENOTED ON THE PLAN, INDICATE THE PROPOSED REGION TO BE RECLAIMED. THE RECLAMATION PROCESS WILL BE AS FOLLOWS:
 2) STOCKPILE AND PROCESSING AREA, SETTLING BASIN, AND BERMS TO BE LEVELED, GRADED AND STABILIZED W/ PERMANENT VEGETATION. ALL SLOPES ASSOCIATED WITH THE EXCAVATED AREA OF THE MINE SHALL BE STABILIZED AND VEGETATED W/ PERMANENT VEGETATION WITHIN 21 DAYS OF COMPLETION
 3) ANY DISTURBED LAND NOT ASSOCIATED WITH THE DAILY OPERATION OF THE MINE SHALL BE STABILIZED AND VEGETATED W/ PERMANENT VEGETATION WITHIN 21 DAYS OF DISTURBANCE.
SEEDING NOTES:
 The minimum requirement for reclamation is that all disturbed areas must be stabilized with a permanent ground cover. It is recommended that due to the close proximity of the proposed mine to the Wildlife Management Area close attention should be taken in the seeding of disturbed lands. Plants should provide erosion control, forage, and cover for a variety of wildlife as well as allow enable native grasses to regenerate over time.
 Staged seeding is generally the most economical and efficient reclamation practice.
 The following table provides seeding specifications for the Coastal Plain Region:
Seeding Mixture

Species	(lbs./ac.)
Korean or Kobe Lespedeza	30
Common Bermudagrass	10
German Millet	10
Rye (grain)	40

Seeding Notes:
 Where a neat appearance is desired, omit Korean or Kobe Lespedeza
 Use Common Bermudagrass only in isolated areas where it cannot become a pest. Bermudagrass may be replaced with 5 Centipedegrass (5 lbs./ac.)
Nurse Plants:
 Prior to May 1 or after August 15, (temporary winter seeding)
 Seeding of Rye (grain) @ 40 lbs./ac.
Seeding Dates:
 Aug 15-May 1,
 (see nurse plants above)
 Apr 1-Aug 15,
 Seeding of German Millet @ 10 lbs./ac.
Year Round:
 Seeding of Korean or Kobe Lespedeza @ 30 lbs./ac.
Soil Amendments:
 Apply lime and fertilizer according to soil tests, or apply 3,000 lb./ac. ground agricultural limestone and 500 lb./ac. 10-10-10 fertilizer.
Mulch:
 Apply 4,000-5,000 lb./ac. grain straw or equivalent cover of another suitable mulching material. Anchor mulch by locking with asphalt, roving, or netting, or by crimping with a mulch-anchoring tool. A disk with blades set nearly straight can be used as a mulch-anchoring tool.
Maintenance:
 Fertilize the following April with 50 lb./ac. nitrogen. Repeat, as growth requires. May be mowed only once a year.
 Where a neat appearance is desired, omit Sericea Lespedeza and mow as often as needed.

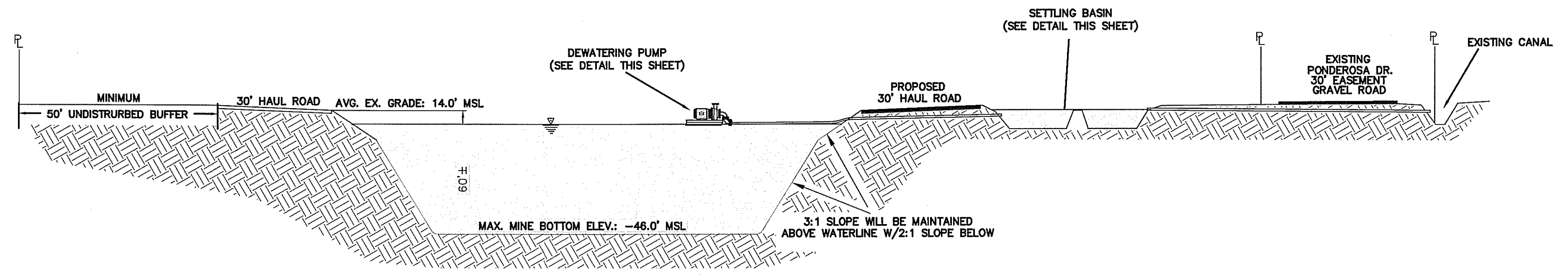

TYPICAL MINE SECTION
 NOT TO SCALE

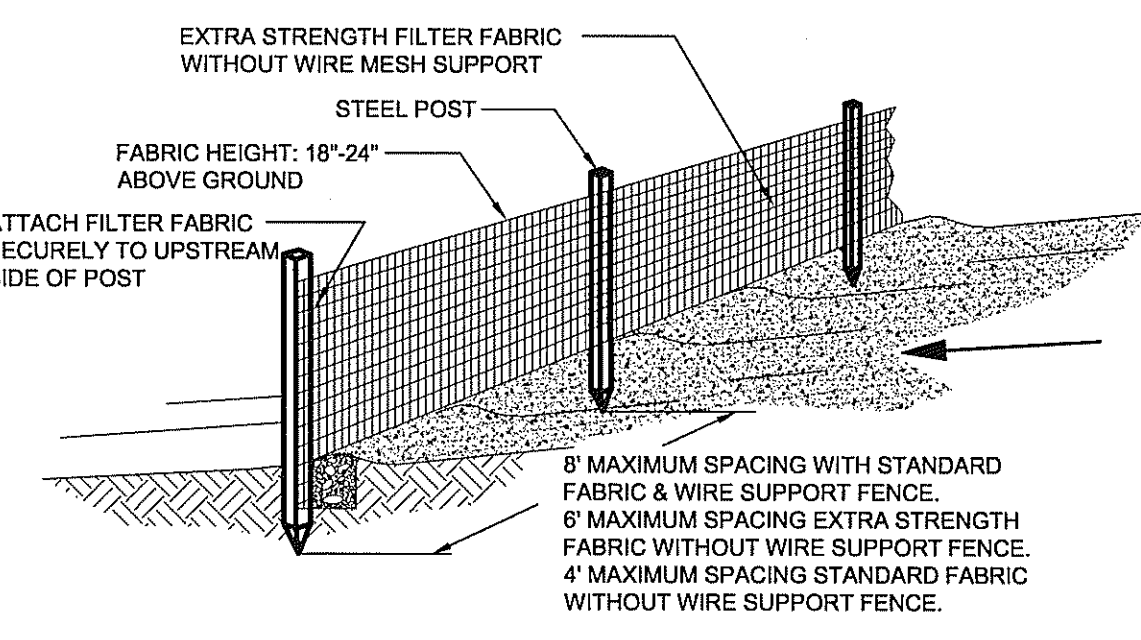

SILT FENCE INSTALLATION
 NOT TO SCALE

SILT FENCE INSTALLATION SPECIFICATIONS:
 1. USE SYNTHETIC FILTER FABRIC OF AT LEAST 85% BY WEIGHT OF POLYOLEFINS OR POLYESTER, WHICH IS CERTIFIED BY THE MANUFACTURER AS CONFORMING TO THE REQUIREMENTS IN ASTM D 6413. FILTER FABRIC SHALL CONTAIN ULTRAVIOLET RAY INHIBITORS AND STABILIZERS TO PROVIDE A MINIMUM OF 6 MONTHS OF EXPECTED USABLE CONSTRUCTION LIFE AT A TEMPERATURE RANGE OF 0 TO 120°F.
 2. FENCE POSTS SHALL BE A MINIMUM OF 1.33 LB/LINEAR FT STEEL AND A MINIMUM LENGTH OF 3 FT. WITH PROJECTIONS TO FACILITATE FASTENING THE FABRIC. WOOD POSTS ARE NO LONGER ACCEPTABLE. POSTS SHALL BE DRIVEN A MINIMUM OF 24" INTO THE GROUND.
 3. CONSTRUCT THE SEDIMENT BARRIER OF EXTRA STRENGTH SYNTHETIC FILTER FABRIC. ENSURE THAT THE HEIGHT OF THE SEDIMENT FENCE DOES NOT EXCEED 24 INCHES ABOVE THE GROUND SURFACE.
 4. CONSTRUCT THE FILTER FABRIC FROM A CONTINUOUS ROLL OUT TO THE LENGTH OF THE BARRIER TO AVOID JOINTS. WHEN JOINTS ARE NECESSARY, SECURELY FASTEN THE FILTER CLOTH ONLY AT A SUPPORT POST WITH 4 FT MINIMUM OVERLAP TO THE NEXT POST.
 5. SYNTHETIC FILTER FABRIC SHALL BE FASTENED SECURELY TO EACH FENCE POST WITH MIN. 50 LB. TENSILE STRENGTH WIRE OR ZIP TIES AT TOP, MID-SECTION AND BOTTOM. FABRIC HEIGHT SHALL BE BETWEEN 18" MIN. TO 24" MAX. ABOVE GROUND LEVEL ON THE UPSLOPE SIDE OF THE POSTS. EXTRA STRENGTH FILTER FABRIC W/ POST SPACING AND SHALL SECURELY FASTENED DIRECTLY TO POSTS. WIRE OR PLASTIC ZIP TIES SHOULD HAVE MINIMUM 50# TENSILE STRENGTH.
 6. 12 INCHES OF FILTER FABRIC SHALL BE BURIED IN AN EXCAVATED TRENCH APPROXIMATELY 4 INCHES WIDE AND 8 INCHES DEEP ALONG THE PROPOSED LINE OF POSTS AND UPSLOPE FROM THE BARRIER. BACKFILL TRENCH WITH MECHANICALLY COMPACTED SOIL PLACED OVER THE FILTER FABRIC. DO NOT ATTACH FILTER FABRIC TO TREES.
 7. SILT FENCE SHALL BE INSPECTED AT LEAST ONCE A WEEK & AFTER EACH RAINFALL EVENT. MAKE ANY REPAIRS IMMEDIATELY. SHOULD THE FABRIC COLLAPSE, TEAR, DECOMPOSE OR BECOME INEFFECTIVE, REPLACE IT PROMPTLY.
 8. REMOVE SEDIMENT DEPOSITS AS NECESSARY TO PROVIDE ADEQUATE STORAGE VOLUME FOR THE NEXT RAIN AND TO REDUCE PRESSURE ON THE FENCE. TAKE CARE TO AVOID UNDOING THE FENCE DURING CLEANOUT.
 9. REMOVE ALL FENCING MATERIALS AND UNSTABLE SEDIMENT DEPOSITS AND BRING THE AREA TO GRADE AND STABILIZE IT AFTER THE CONTRIBUTING DRAINAGE AREA HAS BEEN PROPERLY STABILIZED.

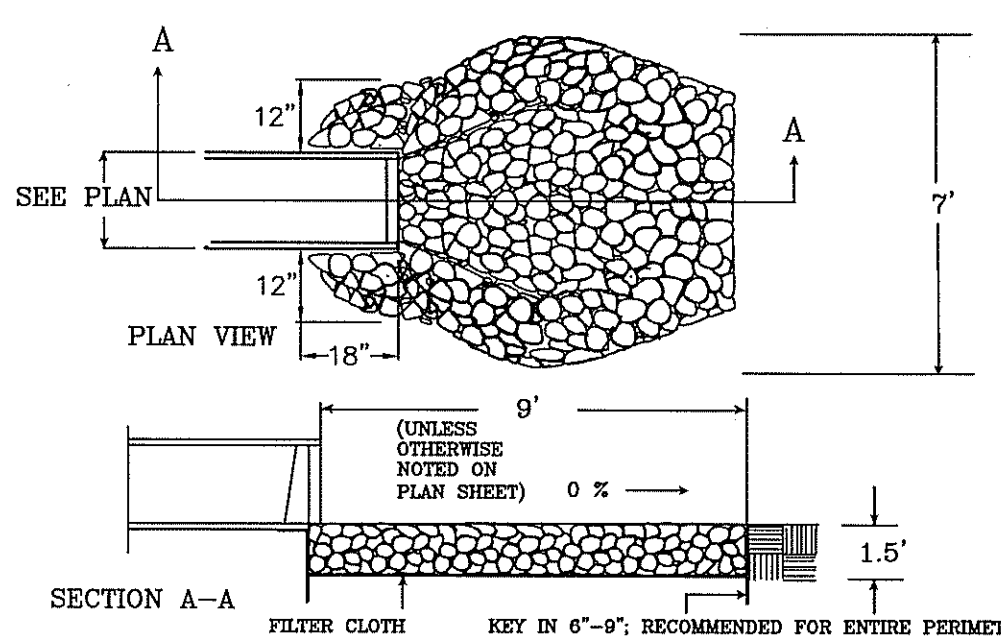

DEWATERING DISCHARGE OUTLET APRON
 NOT TO SCALE
 (LOCATIONS AND SIZE AS DENOTED ON PLAN SHEET)

1. APRON LINING MATERIAL IS RIP-RAP
2. La = THE LENGTH OF THE RIPRAP APRON
3. Wa = THE WIDTH OF THE RIPRAP APRON
4. d = THE STONE DIAMETER IS 8"

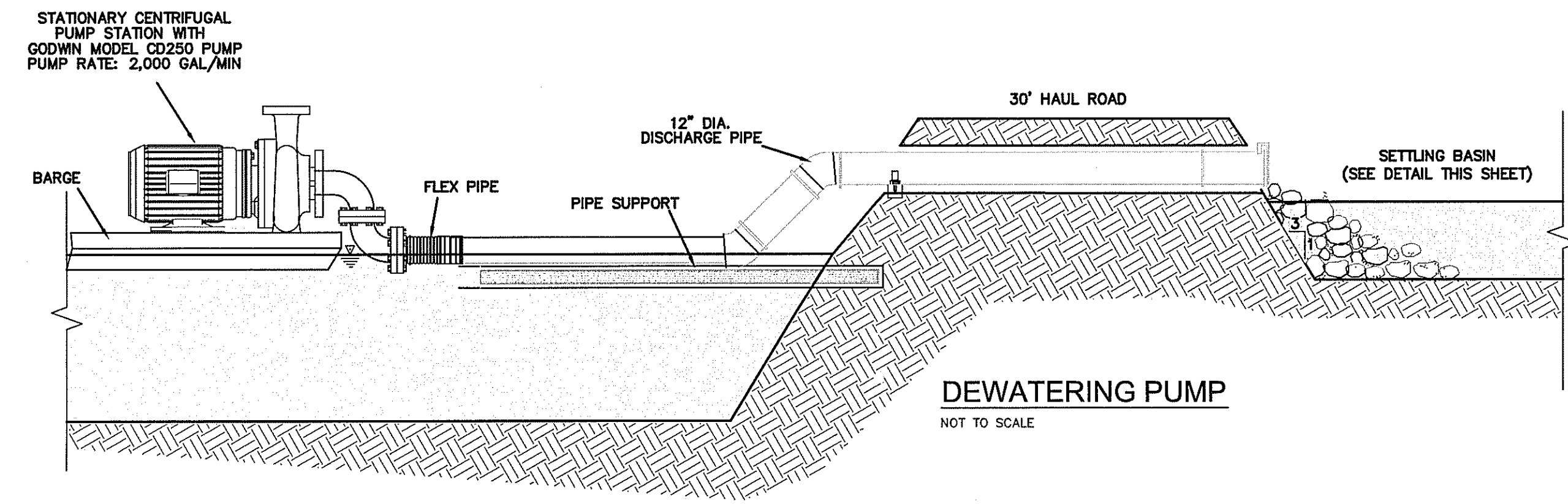

DEWATERING PUMP
 NOT TO SCALE

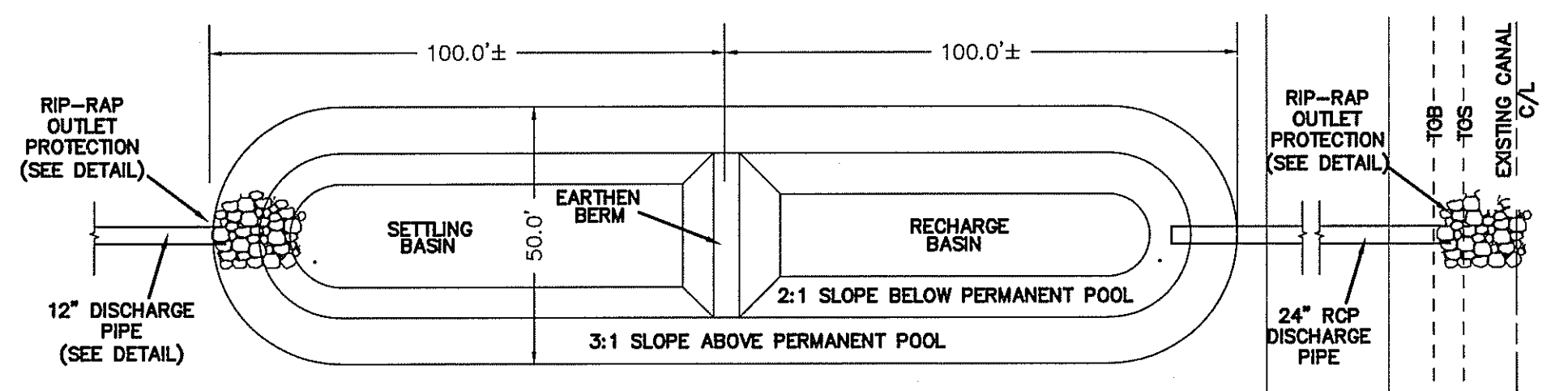

SETTLING BASIN PLAN
 NOT TO SCALE

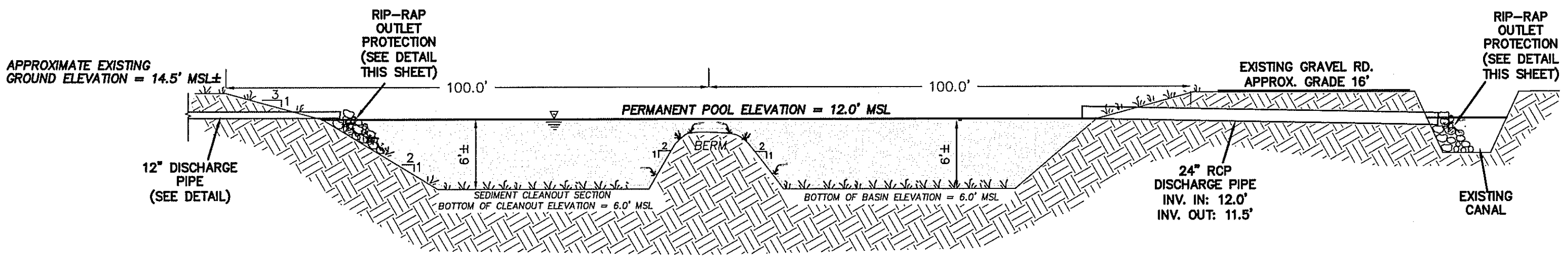

SETTLING BASIN SECTION
 NOT TO SCALE

BRSSELL PROFESSIONAL GROUP
 10000 Old Dominion Highway
 Kitty Hawk, North Carolina 27949
 P.O. Box 10000
 FAX (252) 261-1760

CONSTRUCTION DETAILS
 THIS DOCUMENT IS THE SOLE PROPERTY OF BRG, INC. OF KITTY HAWK, NORTH CAROLINA. THE REPRODUCTION, IN WHOLE OR IN PART, WITHOUT THE EXPRESS WRITTEN CONSENT OF BRG, INC. IS PROHIBITED. BRG, INC. IS NOT RESPONSIBLE FOR ANY ERRORS OR OMISSIONS. BRG, INC. IS NOT RESPONSIBLE FOR ANY CONSEQUENCES ARISING FROM THE USE OF THIS DOCUMENT.
 BRG, INC. PRINCIPAL OF BRG, INC. COPYRIGHT 2005.

BRIGHT MINE - MEIGGS TRACT
 NORTH CAROLINA
 SOUTH MILLS TOWNSHIP
 CAMDEN
MINE DEVELOPMENT/RECLAMATION PLAN

NO.	DATE	DESCRIPTION	BY	CHK
1	03-07-07	ISSUED FOR PERMIT COMMENTS	DMK	MSB

DATE: 03-07-07
 SCALE: NO SCALE
 DESIGNED: BFG
 CHECKED: DMK
 SHEET: 3 OF 3
 CAD FILE: 435800M1
 PROJECT NO: 4358



CAMDENCOUNTY

new energy. new vision.

Board of Commissioners AGENDA ITEM SUMMARY SHEET

New Business

Item Number: 6.A
Meeting Date: March 06, 2017

Submitted By: Stephanie Humphries, Finance Director
Finance
Prepared by: Stephanie Humphries

Item Title **FY 15-16 Audit by Greg Allison of Thompson, Price, Scott, Adams, & Co., PA**

Attachments: Presentation - Camden County - 2016 (PPTX)
2015-2016 Camden County Audit (PDF)
15-16 Balance Sheet (PDF)

Presentation by: Greg Allison
Thompson, Price, Scott, Adams & Co, PA

Summary: FY 2015-2016 Audit presentation



County of Camden
Audit Presentation
For the Year Ended June 30, 2016

County of Camden

Board Meeting

- Presentation of Audit Results
- I. General Comments
- II. Required Communications
- III. Audit Results
- IV. Questions and Comment
- V. Close

County of Camden Required Communications

Area

1 Responsibilities Under Generally Accepted Auditing Standards, Government Auditing Standards, OMB Circular A-133, and the State Single Audit Implementation Act.

Express opinions on these financial statements in conformity with generally accepted auditing standards and *Government Auditing Standards*.

Plan and perform the audit to obtain reasonable, but not absolute, assurance that the financial statements are free of material misstatement and in compliance with government regulations.

Evaluate internal control over financial reporting.

Determine the nature, timing and extent of audit procedures based on risk assessments and our evaluation of internal control.

Perform all planned procedures and have complete access to both management and required information.

Communicate significant deficiencies in the internal control.

Comments

- Accomplished. No material error noted.
- Completed. Our work was not limited in any way.

County of Camden

Required Communications (*continued*)

<u>Area</u>	<u>Comments</u>
<p>2 Adoption or Change in Accounting Policies</p> <p>Communicate the initial adoption of or a change in an accounting principle which had or is expected to have a significant effect on the financial statements.</p>	<ul style="list-style-type: none"> • None noted.
<p>3 Management Judgment and Accounting Estimates</p> <p>Assess methodologies used and basis of evidence for matters requiring judgments and estimates.</p>	<ul style="list-style-type: none"> • Methods used and evidence considered appear to have led to reasonable amounts being included in the financial statements.
<p>4 Financial statement disclosures</p>	<ul style="list-style-type: none"> • The financial statement disclosures are neutral, consistent, and clear.
<p>5 Significant Audit Adjustments or Unrecorded Differences</p> <p>Communicate significant recorded and unrecorded differences.</p>	<ul style="list-style-type: none"> • Certain year-end reclassifications and adjustments based on subsequent information and/or audit testing. None out of the normal course.

County of Camden

Required Communications (*continued*)

<u>Area</u>	<u>Comments</u>
<p>6 Disagreements with Management</p> <p>Communicate any disagreements on financial or reporting matters that, if not satisfactorily resolved, would cause a modification of our report.</p>	<ul style="list-style-type: none"> • None.
<p>7 Management Representations</p>	<ul style="list-style-type: none"> • Management provided a management representation letter dated October 25, 2016.
<p>8 Consultation with Other Accountants</p> <p>Communicate consultation that took place with other accountants.</p>	<ul style="list-style-type: none"> • None to our knowledge.
<p>9 Prior to Retention Issues</p> <p>Communicate any major issues that management discussed with the auditor in connection with the retention of the auditor, including the application of accounting principles and auditing standards.</p>	<ul style="list-style-type: none"> • None.

County of Camden

Required Communications (*continued*)

<u>Area</u>	<u>Comments</u>
10 Difficulties Encountered Performing the Audit	<ul style="list-style-type: none"> • None noted.
<p>Any serious difficulties the auditor encountered in dealing with management such as unreasonable delays in providing needed information, unreasonable timetable set by management, or unavailability of client personnel.</p>	
11 Irregularities and Illegal Acts	<ul style="list-style-type: none"> • None noted.
<p>Communicate the existence of any material irregularities and/or illegal acts determined during the audit.</p>	
12 Other Findings or Issues	<ul style="list-style-type: none"> • No other findings or issues were discussed with, or communicated to management.

County of Camden General Fund

Dear Board Members:		
Below is a summarization of some of the key items in the audit report.		
		<u>2016</u>
Cash and cash equivalents	\$	13,844,084
Total General Fund Revenues	\$	11,885,397
Total General Fund Expenditures	\$	12,183,876
Other Financing Sources	\$	(857,680)
Net Change for year	\$	(1,156,159)
Net position, beginning of year	\$	8,309,353
Net position, end of year	\$	7,153,194
Unassigned Fund Balance as a Percentage of General Fund Expenditures		53.9%

County of Camden

Analysis of cash and cash equivalents by year

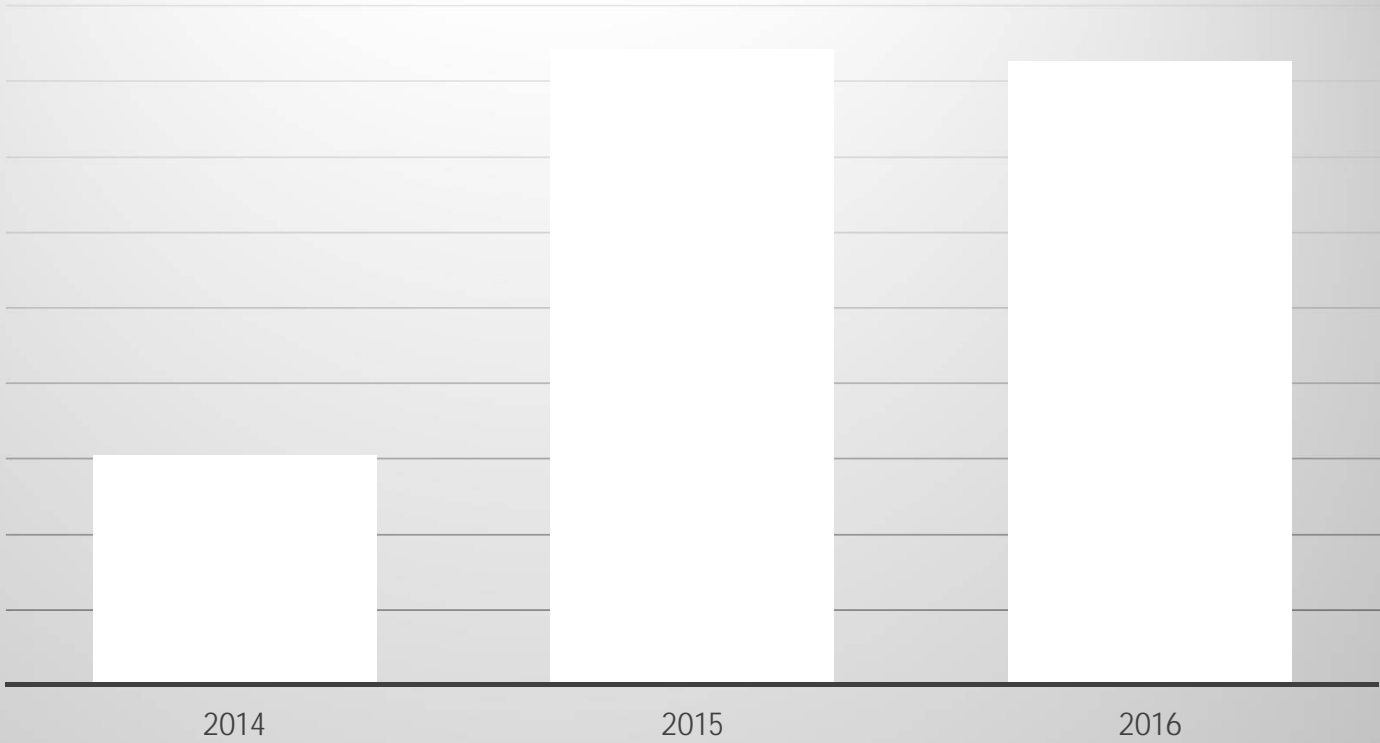

County of Camden

Analysis of Total General Fund Balance to General Fund Expenditures

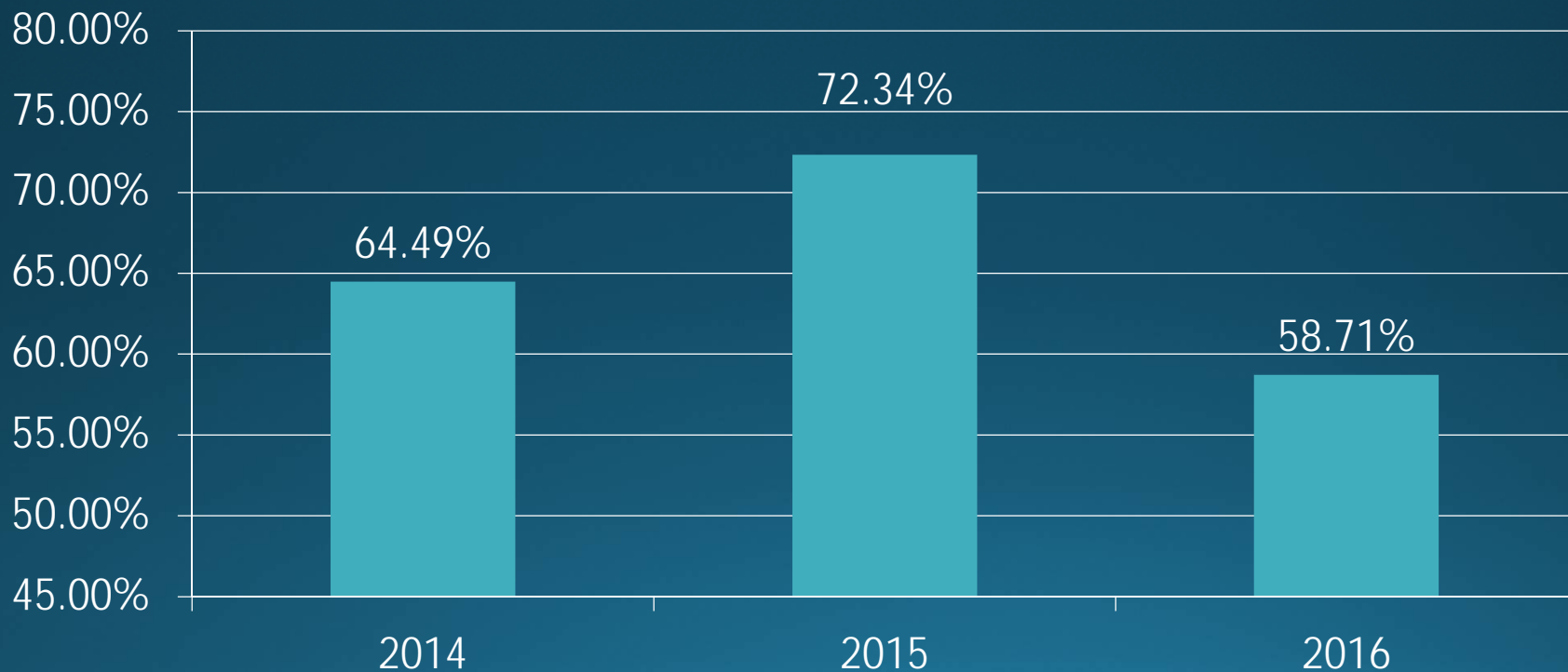

County of Camden Ad Valorem Tax Collections

	<u>Total</u>	<u>Excluding Motor Vehicle</u>	<u>Motor Vehicle Only</u>
Current Year	97.49%	97.24%	100.00%
Statewide	96.47%		

Thank You for the
Opportunity to Work
With You!

CAMDEN COUNTY, NORTH CAROLINA
ANNUAL FINANCIAL REPORT
Year Ended June 30, 2016

BOARD OF COMMISSIONERS

P. Michael McLain, Chairman

Sandy Duckwall, Vice Chairman

Garry Meiggs

Tom White

Clayton Riggs

OFFICIALS

County Manager

Michael Renshaw

Clerk to the Board

Angela Wooten

Finance Officer

Stephanie Humphries

Register of Deeds

Tammie Krauss

Tax Administrator

Lisa Anderson

Sheriff

Tony E. Perry

County Attorney

John Morrison

CAMDEN COUNTY
TABLE OF CONTENTS
June 30, 2016

Exhibit

	Financial Section	
	Independent Auditor's Report	1 - 3
	Management's Discussion and Analysis	4 - 13
	Basic Financial Statements:	
	Government-Wide Financial Statements:	
1	Statement of Net Position	14
2	Statement of Activities	15
	Fund Financial Statements:	
3	Balance Sheet-Governmental Funds	16
	Reconciliation of Governmental Funds Balance Sheet to the Statement of Net Position	
4	Statement of Revenues, Expenditures, and Changes in Fund Balances - Governmental funds	17 - 18
	Reconciliation of the Statement of Revenues, Expenditures, and Changes in Fund Balances of Governmental Funds to the Statement of Activities	
5	Statement of Revenues, Expenditures, and Changes in Fund Balance - Budget and Actual - General, Courthouse and Shiloh FD, & Special Capital Funds	19 - 21
6	Statement of Fund Net Position - Proprietary Fund	22
7	Statement of Revenues, Expenses, and Changes in Fund Net Position - Proprietary Fund	23
8	Statement of Cash Flows - Proprietary Fund	24
9	Statement of Fiduciary Net Position - Fiduciary Fund	25
	Notes to the Financial Statements	26 - 51

Required Supplemental Financial Data:

Other Postemployment Benefits - Schedule of Funding Progress	52
Other Postemployment Benefits - Schedule of Employer Contributions	53
Schedule of the Proportionate Share of the Net Pension Liability – Local Government Employees’ Retirement System	54
Schedule of County Contributions – Local Government Employees’ Retirement System	55
Schedule of the Proportionate Share of the Net Pension Asset – Register of Deeds'	56
Schedule of County Contributions – Register of Deeds'	57
Combining and Individual Fund Statements and Schedules:	
Schedule of Revenues, Expenditures, and Changes in Fund Balances - Budget and Actual -	
General Fund	58 - 62
Fire District Funds- Courthouse and Shiloh	63
Special Capital Fund	64
Combining Balance Sheet for Non-Major Governmental Funds	65
Combining Statement of Revenues, Expenditures, and Changes in Fund Balances for Non-Major Governmental Funds	66
Schedules of Revenues, Expenditures, and Changes in Fund Balances - Budget and Actual:	
Automation Enhancement and Preservation Fund	67
Watershed Fund	68
Dismal Swamp Visitor Center Fund	69
School Capital Fund	70
South Mills Fire District	71
Joyce Creek Drainage District	72
Community Park Trust Fund	73
Eco Dev Fund	74
School Fund	75
Revaluation Fund	76
Scattered Housing Capital Project Fund	77
Enterprise Fund - South Camden Water & Sewer District	78 - 79
Water and Sewer Capital Project Funds	80 - 81
Combining Statement of Fiduciary Assets and Liabilities-Agency Funds	82

Other Schedules:

Schedule of Ad Valorem Taxes Receivable	83
Analysis of Current Tax Levy County-Wide Levy	84
Secondary Market Disclosures	85
Schedule of Ten Largest Taxpayers	86

Compliance Section:

Report on Internal Control Over Financial Reporting and on Compliance and Other matters Based on an Audit of Financial Statements performed in Accordance With <i>Government Auditing Standards</i>	87 - 88
Report on Compliance With Requirements Applicable to Each Major Federal Program and Internal Control Over Compliance in Accordance with OMB Uniform Guidance and the State Single Audit Implementation Act	89 - 90
Report on Compliance With Requirements Applicable to Each Major State Program and Internal Control Over Compliance in Accordance with OMB Uniform Guidance and the State Single Audit Implementation Act	91 - 92
Schedule of Findings and Questioned Costs	93 - 95
Corrective Action Plan	96
Summary Schedule of Prior Audit Findings	97
Schedule of Federal and State Financial Assistance	98 - 101

FINANCIAL SECTION

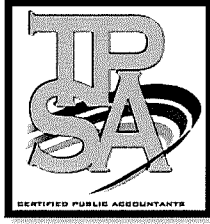

Thompson, Price, Scott, Adams & Co., P.A.
 4024 Oleander Drive Suite 3
 Wilmington, North Carolina 28403
 Telephone (910) 791-4872
 Fax (910) 395-4872

Independent Auditors' Report

To the Board of County Commissioners
 Camden County, North Carolina

Report on the Financial Statements

We have audited the accompanying financial statements of the governmental activities, the business-type activities, the discretely presented component units, each major fund, and the aggregate remaining fund information of Camden County, North Carolina, as of and for the year then ended June 30, 2016, and the related notes to the financial statements, which collectively comprise Camden County's basic financial statements as listed in the table of contents.

Management's Responsibility for the Financial Statements

Management is responsible for the preparation and fair presentation of these financial statements in accordance with accounting principles generally accepted in the United States of America; this includes the design, implementation, and maintenance of internal control relevant to the preparation and fair presentation of financial statements that are free from material misstatement, whether due to fraud or error.

Auditors' Responsibility

Our responsibility is to express opinions on these financial statements based on our audit. We did not audit the financial statements of Camden County ABC Board. Those statements were audited by other auditors whose report has been furnished to us, and our opinion, insofar as it relates to the amounts included for the Camden County ABC Board is based solely on the report of the other auditors. We conducted our audit in accordance with auditing standards generally accepted in the United States of America and the standards applicable to financial audits contained in *Government Auditing Standards*, issued by the Comptroller General of the United States. Those standards require that we plan and perform the audit to obtain reasonable assurance about whether the financial statements are free from material misstatement. The financial statements of Camden County ABC Board and the Camden County TDA were not audited in accordance with *Governmental Auditing Standards*.

An audit involves performing procedures to obtain audit evidence about the amounts and disclosures in the financial statements. The procedures selected depend on the auditors'

Members

American Institute of CPAs – N.C. Association of CPAs – AICPA Division of Firms

judgment, including the assessment of the risks of material misstatement of the financial statements, whether due to fraud or error. In making those risk assessments, the auditors consider internal control relevant to the entity's preparation and fair presentation of the financial statements in order to design audit procedures that are appropriate in the circumstances, but not for the purpose of expressing an opinion on the effectiveness of the entity's internal control. Accordingly we express no such opinion. An audit also includes evaluating the appropriateness of accounting policies used and the reasonableness of significant accounting estimates made by management, as well as evaluating the overall presentation of the financial statements.

We believe that the audit evidence we have obtained is sufficient and appropriate to provide a basis for our audit opinions.

Opinions

In our opinions, based on our audit and the report of the other auditors, the financial statements referred to above present fairly, in all material respects, the respective financial position of the governmental activities, business-type activities, the discretely presented component units, each major fund, and the aggregate remaining fund information of Camden County, North Carolina as of June 30, 2016, and the respective changes in financial position and cash flows, where applicable, thereof and the respective budgetary comparison for the General Fund, Courthouse and Shiloh FD, and Special Capital Fund for the year then ended in accordance with accounting principles generally accepted in the United States of America.

Other Matters

Required Supplementary Information

Accounting principles generally accepted in the United States of America require that the Management's Discussion and Analysis and the Other Postemployment Benefits' Schedules of Funding Progress and Employer Contributions, and the Local Government Employees' Retirement System Schedules of the County's Proportionate Share of Net Pension Liability and County Contributions, and the Register of Deeds' Supplemental Pension Fund Schedule of the County's Proportionate Share of the Net Pension Asset and Schedule of County Contributions be presented to supplement the basic financial statements. Such information, although not a part of the basic financial statements, is required by the Governmental Accounting Standards Board who considers it to be an essential part of financial reporting for placing the basic financial statements in an appropriate operational, economic, or historical context. We and other auditors have applied certain limited procedures to the required supplementary information in accordance with auditing standards generally accepted in the United States of America, which consisted of inquiries of management about the methods of preparing the information and comparing the information for consistency with management's responses to our inquiries, the basic financial statements, and other knowledge we obtained during our audit of the basic financial statements. We do not express an opinion or provide any assurance on the information because the limited procedures do not provide us with sufficient evidence to express an opinion or provide any assurance.

Supplementary and Other Information

Our audit was conducted for the purpose of forming opinions on the financial statements that collectively comprise the basic financial statements of Camden County, North Carolina. The combining and individual fund statements, budgetary schedules, other schedules as well as the accompanying Schedule of Expenditures of Federal and State Awards, *Title 2 U.S. Code of Federal Regulations (CFR) Part 200*, Uniform Administrative Requirements, Cost Principles, and Audit Requirements for Federal Awards and the *State Single Audit Implementation Act* are presented for purposes of additional analysis and are not a required part of the basic financial statements.

The combining and individual fund financial statements, budgetary schedules, other schedules and the Schedule of Expenditures of Federal and State Awards are the responsibility of management and were derived from and relate directly to the underlying accounting and other records used to prepare the basic financial statements. Such information has been subjected to the auditing procedures applied in the audit of the basic financial statements and certain additional procedures, including comparing and reconciling such information directly to the underlying accounting and other records used to prepare the basic financial statements or to the basic financial statements themselves, and other additional procedures in accordance with auditing standards generally accepted in the United States of America by us and other auditors. In our opinion, based on our audit, the procedures performed as described above, and the report of the other auditors, the combining and individual fund financial statements, budgetary schedules, other schedules, and the Schedule of Expenditures of Federal and State Awards are fairly stated, in all material respects, in relation to the basic financial statements as a whole.

Other Reporting Required by Government Auditing Standards

In accordance with *Government Auditing Standards*, we have also issued our report dated December 20, 2016 on our consideration of Camden County's internal control over financial reporting and on our tests of its compliance with certain provisions of laws, regulations, contracts, and grant agreements and other matters. The purpose of the report is to describe the scope of our testing of internal control over financial reporting and compliance and the results of that testing, and not to provide an opinion on internal control over financial reporting or on compliance. That report is an integral part of an audit performed in accordance with *Government Auditing Standards* in considering Camden County's internal control over financial reporting and compliance.

Thompson, Price, Scott, Adams & Co., P.A.

Thompson, Price, Scott, Adams & Co., P.A
Wilmington, North Carolina
December 20, 2016

MANAGEMENT'S DISCUSSION AND ANALYSIS

Management's Discussion and Analysis

As management of Camden County, we offer readers of Camden County's (the "County") financial statements this narrative overview and analysis of the financial activities of the County for the fiscal year ended June 30, 2016. We encourage readers to read the information presented here in conjunction with additional information that we have furnished in the County's financial statements, which follow this narrative.

Financial Highlights

- On the government-wide statements, the assets and deferred outflows of resources of the County's governmental activities exceeded its liabilities and deferred inflows of resources at the close of the fiscal year by \$36,385,666 (*net position*). The County's net assets are impacted considerably by qualified zone academy bonds (QZAB) that the County has issued on behalf of the Camden County Board of Education. The assets are not reflected in the County's financial statements, but the full amount of the long-term debt related to school construction is reflected in the County's financial statements.
- At the end of the fiscal year, fund balance (before any reserves or designations) for the General Fund was \$7,153,194 or 59% total General Fund expenditures for the current fiscal year. Approximately \$6,563,885 remains as unassigned fund balance.
- The County's combined governmental funds reported ending fund balances of \$11,803,303, a decrease of \$1,709,162 related to \$1.5 million investment in two water and sewer infrastructure projects and a new Fire Response Vehicle.
- The County's Net Position increased by \$777,368 for the fiscal year ending June 30, 2016.
- The County's total debt decreased during the fiscal year by \$770,114 from normal principal payments made timely and partial forgiveness of a QZAB loan.

Overview of the Financial Statements

This discussion and analysis is intended to serve as an introduction to Camden County's basic financial statements. The County's basic financial statements consist of three components: 1) government-wide financial statements, 2) fund financial statements, and 3) notes to the financial statements (see Figure 1). The basic financial statements present two different views of the County through the use of government-wide statements and fund financial statements. In addition to the basic financial statements, this report contains other supplemental information that will enhance the reader's understanding of the financial condition of the Camden County.

Required Components of Annual Financial Report

Figure 1

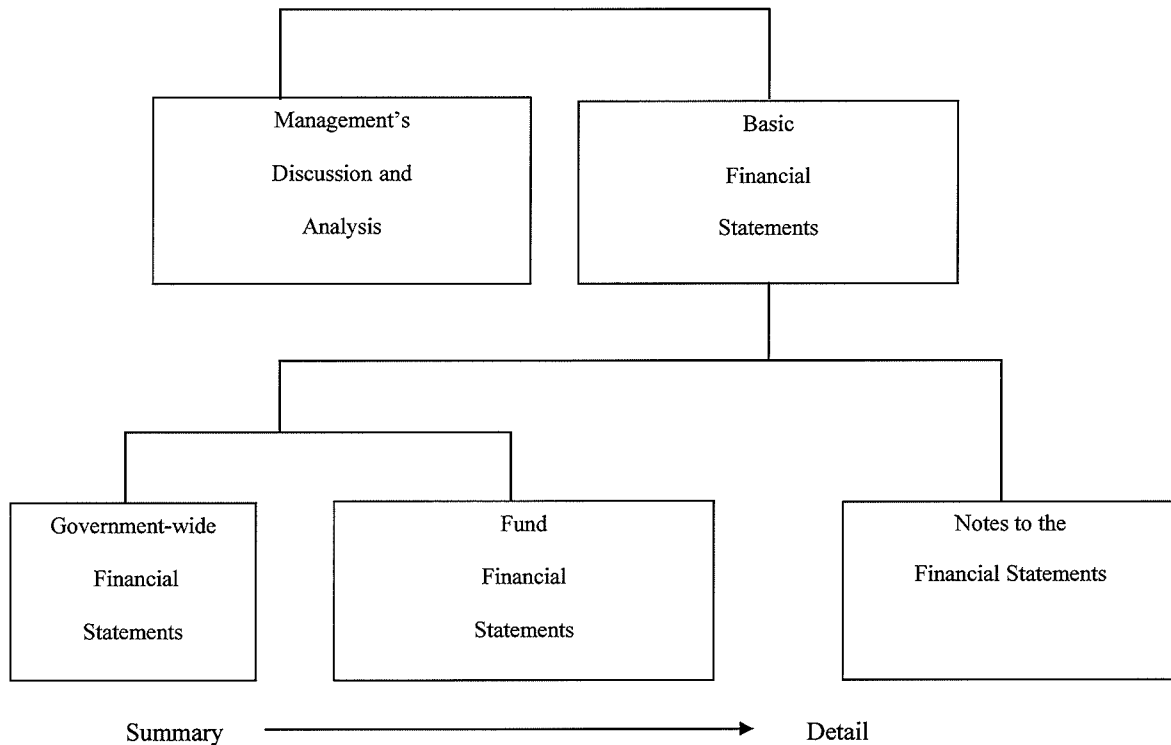

Basic Financial Statements

The first two statements (Exhibits 1&2) in the basic financial statements are the **Government-wide Financial Statements**. They provide both short and long-term information about the County's financial status.

The next statements (Exhibits 3-8) are **Fund Financial Statements**. These statements focus on the activities of the individual parts of the County's government. These statements provide more detail than the government-wide statements. There are four parts to the Fund Financial Statements: 1) the government fund statements; 2) the budgetary comparison statements; 3) the proprietary governmental funds statements; 4) the agency fund statements.

The next section of the basic financial statements is the **notes**. The notes to the financial statements explain in detail some of the data contained in those statements. After the notes, **supplemental information** is provided to show details about the County's major and non-major governmental funds, all of which are added together in one column on the basic financial statements. Budgetary information required by the General Statutes also can be found in this part of the statements.

Following the Notes is the required supplemental information. This section contains funding information about the County's Other Post Employment Benefit Plan and Pension Plans.

Attachment: 2015-2016 Camden County Audit (1494 : FY 15-16 Audit by Greg Allison of Thompson, Price, Scott, Adams, & Co., PA)

Government-Wide Financial Statements

The government-wide financial statements are designed to provide the reader with a broad overview of the County's finances, similar in format to a financial statement of a private-sector business. The government-wide statements provide short and long-term information about the County's financial status as a whole.

The two government-wide statements report the County's net position and how it has changed. Net position is the difference between the County's total assets and total liabilities and deferred inflows of resources. Measuring net position is one way to gauge the County's financial condition.

The government-wide statements are divided into three categories: 1) governmental activities; 2) business-type activities; and 3) component units. The governmental activities include most of the County's basic services such as general administration, taxation and records, human services, education, and public safety. Property taxes, other taxes, and state and federal grant funds finance most of these activities. The business-type activities are those where services are provided and customers are charged for those services. These include the water & sewer services offered by the County. The final category is the component units. The Camden ABC Board and Camden TDA are such units.

The government-wide financial statements are on Exhibits 1 and 2 of this report.

Fund Financial Statements

The Fund Financial Statements (see Figure 1) provide a more detailed look at the County's most significant activities. A fund is a grouping of related accounts that is used to maintain control over resources that have been segregated for specific activities or objectives. Camden County, like all other governmental entities in North Carolina, uses fund accounting to ensure and reflect compliance (or non-compliance) with finance-related legal requirements, such as the North Carolina General Statutes or the County's budget ordinance. All of the funds of the County can be divided into three categories: governmental funds, proprietary funds, and fiduciary fund.

Governmental Funds – Governmental funds are used to account for those functions reported as governmental activities in the government-wide financial statements. Most of the County's basic services are accounted for in the governmental funds. These funds focus on how assets can readily be converted into cash flow in and out, and what monies are left at year-end that will be available for spending in the next year. Governmental funds are reported using an accounting method called *modified accrual accounting* which provides a current financial focus. As a result, the governmental fund financial statements give the reader a detailed short-term view that helps him or her determine if there are more or less financial resources available to finance the County's programs. The relationship between government activities (reported in the Statement of Net Position and the Statement of Activities) and governmental funds is described in a reconciliation that is a part of the fund financial statements.

The County adopts an annual budget for its General Fund, as required by the General Statutes. The budget is a legally adopted document that incorporates input from the citizens of the County, the management of the County, and the decisions of the Board about which services to provide and how to pay for them. It also authorizes the County to obtain funds from identified sources to finance these current period activities. The budgetary statement provided for the General Fund demonstrates how well the County complied with the budget ordinance and whether or not the County succeeded in providing the services as planned when the budget was adopted. The budgetary comparison statement uses the budgetary basis of accounting and is presented using the same format, language, and classifications as the legal budget document. The statement shows four columns: 1) the original budget as adopted by the Board; 2) the final budget as amended by the Board; 3) the actual resources, charges to appropriations, and ending balances in the General Fund; and 4) the difference or variance between the final budget and the actual resources and charges.

Proprietary Funds - The County has one kind of proprietary fund. Enterprise funds are used to report the same functions presented as business-type activities in the government-wide financial statements. The County uses enterprise funds to account for the South Camden Water & Sewer District operations. This fund is the same as those functions shown in the business-type activities in the Statement of Net Position and the Statement of Activities.

Fiduciary Funds - Fiduciary funds are used to account for resources held for the benefit of parties outside the government. The County has four agency funds. These are the funds for Social Services clients, School Tax Fund, Motor Vehicle Tax Fund, and the Nancy M. and H. Clay Ferebee III Camden County Courthouse Trust.

Notes to the Financial Statements - The notes provide additional information that is essential to a full understanding of the data provided in the government-wide and fund financial statements.

Other Information - In addition to the basic financial statements and accompanying notes, this report includes certain required supplementary information concerning Camden County's progress in funding its obligation to provide pension benefits to its employees.

Government-Wide Financial Analysis
Camden County's Net Position
Figure 2

	Governmental Activities		Business-Type Activities		Total	
	2016	2015	2016	2015	2016	2015
Current and other assets	\$ 12,377,909	\$ 14,701,612	\$ 2,633,236	\$ 1,173,629	\$ 15,011,145	\$ 15,875,241
Restricted Cash	249,772	-	-	-	249,772	-
Capital assets	14,181,373	13,640,403	21,949,188	22,178,480	36,130,561	35,818,883
Deferred outflows of resources	239,261	247,713	20,532	22,054	259,793	269,767
Total assets	27,048,315	28,589,728	24,602,956	23,374,163	51,651,271	51,963,891
Long-term liabilities outstanding	10,958,904	11,325,809	2,190,844	2,371,288	13,149,748	13,697,097
Other liabilities	1,585,189	1,552,957	404,370	399,277	1,989,559	1,952,234
Deferred inflows of resources	119,788	640,844	6,510	65,418	126,298	706,262
Total liabilities	12,663,881	13,519,610	2,601,724	2,835,983	15,265,605	16,355,593
Net Position:						
Net investment						
in capital assets	13,004,914	9,198,455	19,577,901	19,583,769	32,582,815	28,782,224
Restricted	1,632,873	2,235,135	-	-	1,632,873	2,235,135
Unrestricted	(253,353)	3,636,528	2,423,331	954,411	2,169,978	4,590,939
Total net position	\$ 14,384,434	\$ 15,070,118	\$ 22,001,232	\$ 20,538,180	\$ 36,385,666	\$ 35,608,298

As noted earlier, net position may serve over time as one useful indicator of a government's financial condition. The assets and deferred outflows of resources of the County exceeded liabilities and deferred inflows of resources by \$36,385,666 as of June 30, 2016. The County's Net Position increased by \$777,368 for the fiscal year ending June 30, 2016. At June 30, 2016, the increase in this category of net position is due to repayment of long-term debt and the purchase of capital assets from funds provided by grants.

Management Discussion and Analysis
Camden County

Net position is reported in three net categories: Net investment in capital assets of \$32,582,815, Restricted assets of \$1,632,873, and Unrestricted net position of \$2,169,978. The amount Net investment in capital assets category is defined as the County's investment in County owned capital assets (e.g. land, buildings, automotive equipment, office and other equipment, and infrastructure) less any related debt still outstanding that was issued to acquire those items. The County uses these capital assets to provide services to citizens; consequently, these assets are not available for future spending. Although the County's investment in its capital assets is reported net of the outstanding related debt, the resources needed to repay that debt must be provided by other sources since the capital assets cannot be used to liquidate these liabilities.

The second category of net position is restricted net position. Restricted resources decreased by \$602,262 for a total of \$1,632,873 at June 30, 2016. Constraints on use are externally imposed by creditors (such as through debt covenants), grantors, contributors, or can be imposed by law through constitutional provisions or legislation.

The final category of net position is unrestricted net position. This balance may be used to meet the government's ongoing obligations to citizens and creditors. At June 30, 2016, the total unrestricted net position decreased to \$2,420,961. The decrease is primarily attributable the retirement of qualified zone academy bonds that were issued on behalf of the school system. Under North Carolina law, the County is responsible for providing capital funding for the school system. The County has chosen to meet its legal obligation to provide the school system capital funding by using a mixture of County funds, earmarked Local Sales Tax collections, loans, and Qualified Zone Academy Bonds. The assets are funded by the County; however, they are utilized by the school system. Since the County, as the issuing government, acquires no capital assets, the County has incurred a liability without a corresponding increase in assets. At the end of the fiscal year, approximately \$14 million of the outstanding debt on the County's financial statements was related to assets included in the school system's financial statements. The school debt is collateralized by a deed of trust granting, among other things, a first lien of record on the Project, including the land constituting a part of the Project, all other buildings, structures, improvement and fixtures thereon, and all appurtenances thereto of any nature whatsoever, excluding mobile or modular classrooms located on the site at any time, subject to permitted encumbrances. Accordingly, the County makes installment payments under the Installment Financing Agreement for payment of the debt. The County's obligation to make payments under the Installment Financing Agreement constitutes a pledge of the County's faith and credit within the meaning of any constitutional provision. Principal and interest requirements will be provided by an appropriation in the year in which they become due.

The impact of the inclusion of the school system debt without the corresponding assets was offset by the following positive operational initiatives and results:

- Camden County has adopted a minimum fund balance policy for the general fund which instructs management to conduct the business of the County in such a manner that available fund balance is at least equal to or greater than 25% of budgeted expenditures.
- Continued diligence in the collection of property taxes (excluding motor vehicles) resulted in maintaining a collection percentage in excess of 97.24%.

Camden County
Changes in Net Position
Figure 3

	Governmental Activities		Business-Type Activities		Total	
	2016	2015	2016	2015	2016	2015
Revenues:						
Program Revenues						
Charges for Services	\$ 1,632,395	\$ 1,120,881	\$ 1,948,548	\$ 1,222,116	\$ 3,580,943	\$ 2,342,997
Operating grants and contributions	1,279,575	1,799,845	-	-	1,279,575	1,799,845
Capital grants and contributions	-	-	-	867,823	-	867,823
General revenues:						
Property taxes	7,384,757	7,536,187	-	-	7,384,757	7,536,187
Other taxes	4,045,616	4,293,940	-	-	4,045,616	4,293,940
Investment earnings	70,606	76,880	6,096	7,378	76,702	84,258
Other	-	45,118	-	-	-	45,118
Total revenues	14,412,949	14,872,851	1,954,644	2,097,317	16,367,593	16,970,168
Expenses:						
General government	3,144,256	2,586,080	-	-	3,144,256	2,586,080
Public Safety	3,897,993	3,553,202	-	-	3,897,993	3,553,202
Economic and physical development	1,277,327	923,131	-	-	1,277,327	923,131
Human services	1,430,698	1,319,313	-	-	1,430,698	1,319,313
Cultural and recreation	513,157	1,019,327	-	-	513,157	1,019,327
Education	2,670,474	2,311,348	-	-	2,670,474	2,311,348
Interest on long-term debt	419,527	429,225	-	-	419,527	429,225
Environmental protection	588,201	541,863	-	-	588,201	541,863
Water	-	-	1,648,592	1,525,819	-	1,525,819
Total expenses	13,941,633	12,683,489	1,648,592	1,525,819	13,941,633	14,209,308
Increase (decrease) in net position before transfers and special items	471,316	2,189,362	306,052	571,498	2,425,960	2,760,860
Transfers	(1,157,000)	(135,018)	1,157,000	135,018	-	-
Increase (decrease) in net position	(685,684)	2,054,344	1,463,052	706,516	777,368	2,760,860
Net position, beginning	15,070,118	13,015,774	20,538,180	19,831,664	35,608,298	32,847,438
Net position, June 30, ending	\$ 14,384,434	\$ 15,070,118	\$ 22,001,232	\$ 20,538,180	\$ 36,385,666	\$ 35,608,298

Governmental activities: Governmental activities decreased the County's net position by \$685,684.

Business-type activities: Business-type activities increased the County's net position by \$1,463,052.

Attachment: 2015-2016 Camden County Audit (1494 : FY 15-16 Audit by Greg Allison of Thompson, Price, Scott, Adams, & Co., PA)

Financial Analysis of the County's Funds

As noted earlier, the County uses fund accounting to ensure and demonstrate compliance with finance-related legal requirements.

Governmental Funds. The focus of the County's governmental funds is to provide information on near-term inflows, outflows, and balances of usable resources. Such information is useful in assessing the Camden County's financing requirements. Specifically, fund balance available for appropriation can be a useful measure of a government's net resources available for spending at the end of the fiscal year.

The general fund is the chief operating fund of the County. At the end of the current fiscal year, the County's fund balance available in the General Fund was \$6,563,885 while total fund balance reached \$7,153,194. The County currently has an unassigned fund balance of 54% of GF expenditures while total fund balance represents 59% of the same amount.

At June 30, 2016, the governmental funds of the County reported a combined fund balance of \$11,803,303, a 13% decrease over last year.

General Fund Budgetary Highlights:

During the fiscal year, the County revised the budget on several occasions. Generally, budget amendments fall into one of three categories: 1) amendments made to adjust the estimates that are used to prepare the original budget ordinance once exact information is available; 2) amendments made to recognize new funding amounts from external sources, such as Federal and State grants; and 3) increases in appropriations that become necessary to maintain services. The total amendments to the General Fund increased revenues by \$197,250 (2%) of the original budget. None of the appropriated Fund Balance was needed to offset the expenditures.

Proprietary Funds: The County's proprietary funds provide the same type of information found in the government-wide statements but in more detail. The total increase in net position was \$1,463,052.

Capital Asset and Debt Administration

Capital assets. The Camden County's investment in capital assets for its governmental and business-type activities as of June 30, 2016, totals \$36,130,561 (net of accumulated depreciation). These assets include land, buildings, automotive equipment, office and other equipment, and water and sewer lines.

Major capital assets transactions during the year include:

- Construction and equipment in the water district.
- Construction and equipment in the governmental funds.

**Camden County's Capital Assets
(net of depreciation)
Figure 4**

	Governmental Activities		Business-Type Activities		Total	
	2016	2015	2016	2015	2016	2015
Land	\$ 5,015,871	\$ 5,015,871	\$ 1,050,394	\$ 768,380	\$ 6,066,265	\$ 5,784,251
Buildings	3,555,924	3,709,139	-	-	3,555,924	3,709,139
Furniture, fixtures and equipment, vehicles	1,833,344	1,046,366	43,789	54,985	1,877,133	1,101,351
Other improvements	3,776,234	3,421,237	20,824,405	21,355,115	24,600,639	24,776,352
Construction in Progress	-	447,790	30,600	-	30,600	447,790
Total	\$ 14,181,373	\$ 13,640,403	\$ 21,949,188	\$ 22,178,480	\$ 36,130,561	\$ 35,818,883

Additional information on the County's capital assets can be found in Note III(a)5 of the Basic Financial Statements.

Long-term Debt: As of June 30, 2016, the South Camden Water & Sewer District had total bonded debt outstanding of \$2,371,287. Other outstanding loans include: Drinking Water State Revolving Loan, \$244,074; State Clean Water Bond Loan, \$505,960. Camden County has \$11,198,273 in outstanding debt that is related to the capital improvement and additional schools built on behalf of the Camden County School Board. The County has several installment notes outstanding as well. A summary of total long-term debt as of June 30, 2016 is shown below:

**Camden County's Outstanding Debt
Figure 5**

	Governmental Activities		Business-type Activities		Total	
	2016	2015	2016	2015	2016	2015
General Obligation Debt	\$ -	\$ -	\$ 2,371,287	\$ 2,594,711	\$ 2,371,287	\$ 2,594,711
Installment Purchases	11,198,273	11,744,963	-	-	11,198,273	11,744,963
Total	\$ 11,198,273	\$ 11,744,963	\$ 2,371,287	\$ 2,594,711	\$ 13,569,560	\$ 14,339,674

The State of North Carolina limits the amount of general obligation debt that a unit of government can issue to 8 percent of the total assessed value of taxable property located within that government's boundaries. The debt margin required by local Resolution is 2%. The current debt margin for Camden County (as calculated on assessed real property only) is 1.5% or \$13,569,559. Well below the allowable debt limit for the County. Additional information regarding the County's long-term debt can be found in Note 6 of this report.

Attachment: 2015-2016 Camden County Audit (1494 : FY 15-16 Audit by Greg Allison of Thompson, Price, Scott, Adams, & Co., PA)

Economic Factors and Next Year's Budgets and Rates

- The unemployment rate in the County was at 5.6% on June 30, 2016, compared with a federal rates of 4.9% and a State rate of 4.9%. The rate for Camden County was 6.2% at the end of the prior fiscal year.
- New residential unit construction permits were 37 units this year. Total new residential construction permits increased to \$9,384,900 for this fiscal year.

Budget Highlights for the Fiscal Year Ending June 30, 2017

Governmental Activities

The County has approved an \$12.6 general budget for the fiscal year 2017. This will be accomplished with an expected increase in Sales Tax Revenues, county ad valorem tax growth, and a portion of Appropriated Fund Balance to increase the funding appropriated to the Camden County Board of Education. Budgeted expenditures for education in the General Fund for 2017 increased to \$2.3 million through a General Fund appropriation. Capital outlay for the schools is budgeted at \$298,758 through General Fund appropriation and the debt service payments, related to school construction and renovation, are budgeted at \$692,844 and will be funded from the School Capital Reserve Fund which gets its revenue from an earmarked portion of the sales tax, and General Fund appropriations as needed.

Several factors will positively affect the economic outlook of the county over the next several fiscal years. Economic forecasts indicate growth in coming years which, while modest, are positive indicators for prospective commercial growth in the county. The County has applied for grants for a \$2.3 million Water Treatment Plant. The federal Economic Development Commission grant request along with a Golden LEAF grant and matching County funds will provide funding for a new plant that will allow for commercial expansion along Hwy 158. We have already seen an increase in interest from the retail sectors to locate in Camden County with the recent construction of a Dollar General and a Hardee's as well as the planned Towne Center project; all of which will expand the tax base and provide employment

Factors that may negatively affect the economic position of the county include the unexpected change to the sales tax restructuring. While the change provides additional funds for school capital and economic development, an unrestricted allocation would have been more promising. Another limiting factor is changes that may occur in the state and federal political arena. These changes could create local impacts which causes a large amount of uncertainty for Local Government and Camden County.

Business-type Activities

The South Camden Water District is currently completing a Fresh Water Well project that required \$400,000 in County contributions in 2015-2016. The County has allocated an additional \$1.1 million in funds for engineering, design and construction of a second wastewater treatment plant to be located in the Courthouse Township. As both of these projects are completed, the SCWD expects to be in a better position to provide adequate water and sewer with Camden County. The return on this investment is expected to come from the ability to market adequate capacity for commercial development.

Requests for Information

This report is designed to provide an overview of the County's finances for those with an interest in this area. Questions concerning any of the information found in this report or requests for additional information should be directed to the Finance Officer, Camden County, 330 East Hwy. 158, P.O. Box 190, Camden, NC 27921. You can also call 1-252-338-6363 for more information.

BASIC FINANCIAL STATEMENTS

Camden County, North Carolina
Statement of Net Position
June 30, 2016

	Primary Government			Component Units	
	Governmental Activities	Business-type Activities	Total	Camden County ABC Board	Camden County TDA
ASSETS					
Cash and cash equivalents	\$ 11,110,413	\$ 2,483,899	\$ 13,594,312	\$ 102,865	\$ 94,340
Restricted cash	249,772	-	249,772	-	-
Taxes receivable, net	273,398	-	273,398	-	-
Accounts receivable, net	881,802	149,337	1,031,139	-	2,086
Inventories	-	-	-	126,048	-
Prepaid expenses	-	-	-	7,782	-
Accrued interest on taxes receivable	90,223	-	90,223	-	-
Net pension asset	22,073	-	22,073	-	-
Capital assets:					
Land, non-depreciable improvements, and construction in progress	5,015,871	1,080,994	6,096,865	25,405	-
Other capital assets, net of depreciation	9,165,502	20,868,194	30,033,696	113,737	-
Total assets	<u>26,809,054</u>	<u>24,582,424</u>	<u>51,391,478</u>	<u>375,837</u>	<u>96,426</u>
DEFERRED OUTFLOWS OF RESOURCES	<u>239,261</u>	<u>20,532</u>	<u>259,793</u>	<u>11,597</u>	<u>-</u>
LIABILITIES					
Accounts payable and accrued liabilities	426,256	63,461	489,717	120,859	8
Accrued interest payable	93,420	-	93,420	-	-
Compensated absences payable	79,662	11,389	91,051	-	-
Other postemployment benefits	431,861	83,300	515,161	-	-
Current-portion of long-term liabilities	553,990	225,324	779,314	-	-
Long-term liabilities					
Net pension liability - LGERS	196,545	21,838	218,383	4,398	-
Compensated absences payable	118,076	23,043	141,119	-	-
Due in more than one year	10,644,283	2,145,963	12,790,246	-	-
Total liabilities	<u>12,544,093</u>	<u>2,574,318</u>	<u>15,118,411</u>	<u>125,257</u>	<u>8</u>
DEFERRED INFLOWS OF RESOURCES					
Pension deferrals	107,360	6,510	113,870	2,286	-
Prepaid taxes	12,428	-	12,428	-	-
Total deferred inflows of resources	<u>119,788</u>	<u>6,510</u>	<u>126,298</u>	<u>2,286</u>	<u>-</u>
NET POSITION					
Net investment in capital assets	13,004,914	19,577,901	32,582,815	139,142	-
Stabilization by State Statute	884,339	-	884,339	-	2,086
Register of Deeds	11,363	-	11,363	-	-
Fire Protection	487,962	-	487,962	-	-
School Capital	249,209	-	249,209	-	-
Capital Improvement	-	-	-	-	-
Unrestricted	(253,353)	2,423,331	2,169,978	120,749	94,332
Total net position	<u>\$ 14,384,434</u>	<u>\$ 22,001,232</u>	<u>\$ 36,385,666</u>	<u>\$ 259,891</u>	<u>\$ 96,418</u>

The notes to the financial statements are an integral part of this statement.

Exhibit 2

Camden County, North Carolina
Statement of Activities
For the Year Ended June 30, 2016

Functions/Programs	Program Revenues				Net (Expense) Revenue and Changes in Net Position			Component Unit	
	Expenses	Charges for Services	Operating Grants and Contributions	Capital Grants and Contributions	Primary Government		Camden County ABC Board	Camden County TDA	
					Governmental Activities	Business-type Activities	Total		
Primary government:									
Governmental Activities:									
General government	\$ 3,144,256	\$ 304,765	\$ -	\$ -	\$ (2,839,491)	\$ -	\$ (2,839,491)		
Public safety	3,897,993	553,501	134,155	-	(3,210,337)	-	(3,210,337)		
Cultural and recreation	513,157	-	142,857	-	(370,300)	-	(370,300)		
Economic and physical development	1,277,327	227,492	-	-	(1,049,835)	-	(1,049,835)		
Human services	1,430,698	-	965,506	-	(465,192)	-	(465,192)		
Education	2,670,474	448,783	-	-	(2,221,691)	-	(2,221,691)		
Environmental protection	588,201	97,854	37,057	-	(453,290)	-	(453,290)		
Interest on long-term debt	419,527	-	-	-	(419,527)	-	(419,527)		
Total governmental activities	13,941,633	1,632,395	1,279,575	-	(11,029,663)	-	(11,029,663)		
Business-type activities:									
Water	1,648,592	1,948,548	-	-	-	299,956	299,956		
Total business-type activities	1,648,592	1,948,548	-	-	-	299,956	299,956		
	\$ 15,590,225	\$ 3,580,943	\$ 1,279,575	\$ -	\$ (11,029,663)	\$ 299,956	\$ (10,729,707)		
Component units:									
TDA	\$ 28,670	\$ -	\$ -	\$ -			\$ -	\$ (28,670)	
ABC Board	1,360,640	1,362,653	-	-			2,013	-	
Total component units	\$ 1,360,640	\$ 1,362,653	\$ -	\$ -			\$ 2,013	\$ (28,670)	
General revenues:									
Taxes:									
Property taxes, levied for general purpose					7,384,757	-	7,384,757	-	
Local option sales tax					1,047,860	-	1,047,860	-	
Other taxes and licenses					2,997,756	-	2,997,756	35,741	
Grants and contributions not restricted to specific programs					-	-	-	-	
Investment earnings, unrestricted					70,606	6,096	76,702	20	
Miscellaneous, unrestricted					-	-	-	41	
Transfer to component unit					-	-	-	-	
Transfers					(1,157,000)	1,157,000	-	-	
Total general revenues, special items, and transfers					10,343,979	1,163,096	11,507,075	20	
Change in net position					(685,684)	1,463,052	777,368	2,033	
Net position, beginning					15,070,118	20,538,180	35,608,298	257,858	
Net position-ending					\$ 14,384,434	\$ 22,001,232	\$ 36,385,666	\$ 259,891	

The notes to the financial statements are an integral part of this statement.

15

**Camden County, North Carolina
Balance Sheet
Governmental Funds
June 30, 2016**

	Major			NonMajor Other	Total Governmental Funds
	General Fund	Courthouse and Shiloh FD	Special Capital Fund	Governmental Funds	
ASSETS					
Cash, including time deposits	\$ 6,858,036	\$ 233,670	\$ 2,580,996	\$ 1,437,711	\$ 11,110,413
Restricted cash	-	-	-	249,772	249,772
Accounts receivable, net	858,593	11,635	-	284,972	1,155,200
Due from other funds	119,500	-	-	-	119,500
Total assets	<u>\$ 7,836,129</u>	<u>\$ 245,305</u>	<u>\$ 2,580,996</u>	<u>\$ 1,972,455</u>	<u>\$ 12,634,885</u>
LIABILITIES AND FUND BALANCES					
Liabilities:					
Accounts payable and accrued liabilities	401,223	731	-	24,302	426,256
Due to other funds	-	119,500	-	-	119,500
Unearned revenue	-	-	-	-	-
Total liabilities	<u>401,223</u>	<u>120,231</u>	<u>-</u>	<u>24,302</u>	<u>545,756</u>
DEFERRED INFLOWS OF RESOURCES					
Property taxes receivable	269,284	2,537	-	1,577	273,398
Prepaid taxes	12,428	-	-	-	12,428
Total deferred inflows of resources	<u>281,712</u>	<u>2,537</u>	<u>-</u>	<u>1,577</u>	<u>285,826</u>
Fund balances:					
Restricted					
Stabilization by State Statute	589,309	11,635	-	283,395	884,339
Register of Deeds	-	-	-	11,363	11,363
Fire Protection	-	110,902	-	377,060	487,962
School Capital	-	-	-	249,209	249,209
Committed					
Capital Reserve	-	-	2,580,996	-	2,580,996
Tax Revaluation	-	-	-	359,890	359,890
Economic Development	-	-	-	665,659	665,659
Unassigned	6,563,885	-	-	-	6,563,885
Total fund balances	<u>7,153,194</u>	<u>122,537</u>	<u>2,580,996</u>	<u>1,946,576</u>	<u>11,803,303</u>
Total liabilities, deferred inflows of resources and fund balances	<u>\$ 7,836,129</u>	<u>\$ 245,305</u>	<u>\$ 2,580,996</u>	<u>\$ 1,972,455</u>	

Amounts reported for governmental activities in the statement of net position (Exhibit 1) are different because:

Net pension asset.	22,073
Contributions to the pension plan in the current fiscal year are deferred outflows of resources on the Statement of Net Position.	239,261
Liabilities for earned revenues considered deferred inflows of resources in fund statements.	273,398
Other assets are not available to pay for current-period expenditures and therefore are not accrued as income in the funds.	90,223
Capital assets used in governmental activities are not financial resources and therefore are not reported in the funds.	14,181,373
Pension related deferrals.	(107,360)
Long-term debt included as net position below (includes the addition of long-term debt and principal payments during the year.)	(11,921,292)
Net pension liability.	(196,545)
Net position of governmental activities	<u>\$ 14,384,434</u>

Camden County, North Carolina
Statement of Revenues, Expenditures, and Changes in Fund Balance
Governmental Funds
For the Year Ended June 30, 2016

	Major			Non Major Other	Total Governmental Funds
	General Fund	Courthouse and Shiloh FD	Special Capital Fund	Governmental Funds	
REVENUES					
Ad valorem taxes	\$ 7,325,931	\$ 66,572	\$ -	\$ 61,052	\$ 7,453,555
Other taxes and licenses	2,489,181	261,765	428,919	730,149	3,910,014
Unrestricted intergovernmental	81,630	-	-	-	81,630
Restricted intergovernmental	1,129,080	2,000	-	400,349	1,531,429
Local Contributions	-	-	-	488,783	488,783
Permits and fees	672,557	9,373	-	103,351	785,281
Sales and services	95,271	-	-	30,722	125,993
Investment earnings	44,386	1,361	14,957	9,902	70,606
Miscellaneous	47,361	50	-	859	48,270
Total revenues	<u>11,885,397</u>	<u>341,121</u>	<u>443,876</u>	<u>1,825,167</u>	<u>14,495,561</u>
EXPENDITURES					
Current:					
General government	1,918,590	-	970,846	220,294	3,109,730
Public safety	3,683,203	688,048	-	132,620	4,503,871
Environmental protection	568,034	-	-	9,685	577,719
Economic and physical development	795,946	-	-	439,558	1,235,504
Culture and recreation	594,078	-	-	-	594,078
Human services	1,387,965	-	-	-	1,387,965
Intergovernmental:					
Education	2,371,725	-	-	298,748	2,670,473
Debt service:					
Principal	469,649	-	-	77,042	546,691
Interest	394,686	-	-	27,006	421,692
Total expenditures	<u>12,183,876</u>	<u>688,048</u>	<u>970,846</u>	<u>1,204,953</u>	<u>15,047,723</u>
Excess (deficiency) of revenues over expenditures	<u>(298,479)</u>	<u>(346,927)</u>	<u>(526,970)</u>	<u>620,214</u>	<u>(552,162)</u>
OTHER FINANCING SOURCES					
Proceeds of long-term debt	-	-	-	-	-
Transfer to component unit	-	-	-	-	-
Transfers to other funds	(857,680)	-	-	(624,320)	(1,482,000)
Transfers from other funds	-	-	325,000	-	325,000
Total other financing sources and uses	<u>(857,680)</u>	<u>-</u>	<u>325,000</u>	<u>(624,320)</u>	<u>(1,157,000)</u>
Net change in fund balance	(1,156,159)	(346,927)	(201,970)	(4,106)	(1,709,162)
Fund balances-beginning	8,309,353	469,464	2,782,966	1,950,682	13,512,465
Fund balances-ending	<u>\$ 7,153,194</u>	<u>\$ 122,537</u>	<u>\$ 2,580,996</u>	<u>\$ 1,946,576</u>	<u>\$ 11,803,303</u>

Camden County, North Carolina
Statement of Revenues, Expenditures, and Changes in Fund Balance
Governmental Funds
For the Year Ended June 30, 2016

Amounts reported for governmental activities in the statement of activities are different because:

Net changes in fund balance - total government funds \$ (1,709,162)

Governmental funds report capital outlays as expenditures. However, in the Statement of Activities the cost of those assets is allocated over their estimated useful lives and reported as depreciation expense. This is the amount by which capital outlays increases exceeded the book value of capital outlay decreases in fiscal year.

Capital outlay expenditures which were capitalized	1,198,963	
Depreciation expense for governmental assets	<u>(644,179)</u>	554,784

Cost of asset disposed of during the year		30,890
-------------------------------------------	--	--------

Contributions to the pension plan in the current fiscal year are not included on the Statement of Activities		190,683
--------------------------------------------------------------------------------------------------------------	--	---------

Revenues in the statement of activities that do not provide current financial resources are not reported as revenues in the funds:		(117,106)
------------------------------------------------------------------------------------------------------------------------------------	--	-----------

The issuance of long-term debt provides current financial resources to governmental funds, while the repayment of the principal of long-term debt consumes the current financial resources of governmental funds. Neither transaction has any effect on net position. This amount is the net effect of these differences in the treatment of long-term debt and related items.		546,691
--------------------------------------------------------------------------------------------------------------------------------------------------------------------------------------------------------------------------------------------------------------------------------------------------------------------------------------------------------------------------------	--	---------

Some expenses reported in the Statement of Activities do not require the use of current financial resources and therefore, are not reported as expenditures in governmental funds.

Accrued interest	2,165	
Compensated absences	11,047	
Pension expense	(127,269)	
Other postemployment benefits	<u>(68,407)</u>	(182,464)

Total changes in net position of governmental activities		<u>\$ (685,684)</u>
----------------------------------------------------------	--	---------------------

The notes to the financial statements are an integral part of this statement.

Camden County, North Carolina
Statement of Revenues, Expenditures, and Changes in Fund Balances -
Budget and Actual
For the Year Ended June 30, 2016

	General Fund			Variance With Final Positive (Negative)
	Original Budget	Final Budget	Actual	
Revenues:				
Ad valorem taxes	\$ 7,133,570	\$ 7,226,231	\$ 7,325,931	\$ 99,700
Other taxes and licenses	2,486,000	2,486,000	2,489,181	3,181
Unrestricted intergovernmental revenues	76,800	81,216	81,630	414
Restricted intergovernmental revenues	1,162,250	1,188,686	1,129,080	(59,606)
Permits and fees	642,290	699,726	672,557	(27,169)
Sales and services	82,600	89,850	95,271	5,421
Local contributions	-	-	-	-
Investment earnings	47,178	47,178	44,386	(2,792)
Miscellaneous	19,000	28,051	47,361	19,310
Total revenues	<u>11,649,688</u>	<u>11,846,938</u>	<u>11,885,397</u>	<u>38,459</u>
Expenditures				
Current:				
General government	2,022,510	2,144,775	1,918,590	226,185
Public safety	3,604,577	3,703,945	3,683,203	20,742
Economic and physical development	704,797	708,712	568,034	140,678
Environmental protection	770,520	816,817	795,946	20,871
Human Services	1,468,122	1,567,215	1,387,965	179,250
Cultural and recreational	626,958	628,034	594,078	33,956
Intergovernmental:				
Education	2,396,725	2,371,725	2,371,725	-
Debt service:				
Principal retirement	469,649	469,649	469,649	-
Interest	394,686	394,686	394,686	-
Total expenditures	<u>12,458,544</u>	<u>12,805,558</u>	<u>12,183,876</u>	<u>621,682</u>
Revenues over (under) expenditures	(808,856)	(958,620)	(298,479)	660,141
Other financing sources (Uses)				
Proceeds from installment purchases	-	-	-	-
Transfers from other funds	-	1,723,393	715,949	(1,007,444)
Transfers to other funds	-	(1,573,629)	(1,573,629)	-
Fund Balance Appropriated	808,856	808,856	-	(808,856)
Total other financing sources and uses	<u>808,856</u>	<u>958,620</u>	<u>(857,680)</u>	<u>(1,816,300)</u>
Net change in fund balance	<u>\$ -</u>	<u>\$ -</u>	(1,156,159)	<u>\$ (1,156,159)</u>
Fund Balances - Beginning			8,309,353	
Fund Balances - Ending			<u>\$ 7,153,194</u>	

The notes to the financial statements are an integral part of this statement.

Camden County, North Carolina
Statement of Revenues, Expenditures, and Changes in Fund Balances -
Budget and Actual
For the Year Ended June 30, 2016

	Courthouse and Shiloh FD			Variance With Final Positive (Negative)
	Original Budget	Final Budget	Actual	
Revenues:				
Ad valorem taxes	\$ 60,863	\$ 60,863	\$ 66,572	\$ 5,709
Other taxes and licenses	243,453	243,453	261,765	18,312
Unrestricted intergovernmental revenues	-	-	-	-
Restricted intergovernmental revenues	30,000	30,000	2,000	(28,000)
Permits and fees	9,000	9,000	9,373	373
Sales and services	-	-	-	-
Local contributions	219,500	219,500	-	(219,500)
Investment earnings	3,000	3,000	1,361	(1,639)
Miscellaneous	-	-	50	50
Total revenues	<u>565,816</u>	<u>565,816</u>	<u>341,121</u>	<u>(224,695)</u>
Expenditures				
Current:				
General government	-	-	-	-
Public safety	785,778	829,775	688,048	141,727
Economic and physical development	-	-	-	-
Environmental protection	-	-	-	-
Human Services	-	-	-	-
Cultural and recreational	-	-	-	-
Intergovernmental:				
Education	-	-	-	-
Debt service:				
Principal retirement	-	-	-	-
Interest	-	-	-	-
Total expenditures	<u>785,778</u>	<u>829,775</u>	<u>688,048</u>	<u>141,727</u>
Revenues over (under) expenditures	(219,962)	(263,959)	(346,927)	(82,968)
Other financing sources (Uses)				
Proceeds from installment purchases	-	-	-	-
Transfers from other funds	-	-	-	-
Transfers to other funds	-	-	-	-
Fund Balance Appropriated	219,962	263,959	-	(263,959)
Total other financing sources and uses	<u>219,962</u>	<u>263,959</u>	<u>-</u>	<u>(263,959)</u>
Net change in fund balance	<u>\$ -</u>	<u>\$ -</u>	(346,927)	<u>\$ (346,927)</u>
Fund Balances - Beginning			469,464	
Fund Balances - Ending			<u>\$ 122,537</u>	

The notes to the financial statements are an integral part of this statement.

Camden County, North Carolina
Statement of Revenues, Expenditures, and Changes in Fund Balances -
Budget and Actual
For the Year Ended June 30, 2016

	Special Capital Fund			Variance With Final Positive (Negative)
	Original Budget	Final Budget	Actual	
Revenues:				
Ad valorem taxes	\$ -	\$ -	\$ -	\$ -
Other taxes and licenses	300,000	300,000	428,919	128,919
Unrestricted intergovernmental revenues	-	-	-	-
Restricted intergovernmental revenues	-	-	-	-
Permits and fees	-	-	-	-
Sales and services	-	-	-	-
Local contributions	-	-	-	-
Investment earnings	20,000	20,000	14,957	(5,043)
Miscellaneous	-	-	-	-
Total revenues	<u>320,000</u>	<u>320,000</u>	<u>443,876</u>	<u>123,876</u>
Expenditures				
Current:				
General government	1,722,083	1,722,083	970,846	751,237
Public safety	-	-	-	-
Economic and physical development	-	-	-	-
Environmental protection	-	-	-	-
Human Services	-	-	-	-
Cultural and recreational	-	-	-	-
Intergovernmental:				
Education	-	-	-	-
Debt service:				
Principal retirement	-	-	-	-
Interest	-	-	-	-
Total expenditures	<u>1,722,083</u>	<u>1,722,083</u>	<u>970,846</u>	<u>751,237</u>
Revenues over (under) expenditures	(1,402,083)	(1,402,083)	(526,970)	875,113
Other financing sources (Uses)				
Proceeds from installment purchases	-	-	-	-
Transfers from other funds	325,000	325,000	325,000	-
Transfers to other funds	-	-	-	-
Fund Balance Appropriated	<u>1,077,083</u>	<u>1,077,083</u>	<u>-</u>	<u>(1,077,083)</u>
Total other financing sources and uses	<u>1,402,083</u>	<u>1,402,083</u>	<u>325,000</u>	<u>(1,077,083)</u>
Net change in fund balance	<u>\$ -</u>	<u>\$ -</u>	(201,970)	<u>\$ (201,970)</u>
Fund Balances - Beginning			2,782,966	
Fund Balances - Ending			<u>\$ 2,580,996</u>	

The notes to the financial statements are an integral part of this statement.

Camden County, North Carolina
Statement of Fund Net Position
Proprietary Fund
June 30, 2016

	Major
	South Camden Water & Sewer District
Assets	
Current Assets:	
Cash and cash equivalents	\$ 2,483,899
Accounts receivable, net	149,337
Total Current Assets	2,633,236
Noncurrent assets:	
Capital assets:	
Land and non-depreciable assets	1,080,994
Other capital assets, net of depreciation	20,868,194
Capital assets (net)	21,949,188
Total noncurrent assets	21,949,188
Total Assets	24,582,424
Deferred Outflows of Resources	
Contributions to pension plan in current fiscal year	20,532
Total deferred outflows of resources	20,532
Liabilities	
Current Liabilities:	
Accounts payable & accrued liabilities	63,461
Current portion of long-term debt	225,324
Compensated absences	11,389
Accrued Interest	20,896
Due to other funds	-
Total Current Liabilities	321,070
Noncurrent liabilities:	
Compensated absences	23,043
Other postemployment benefits	83,300
Net pension liability	21,838
Long term obligations payable	2,145,963
Total noncurrent liabilities	2,274,144
Total Liabilities	2,595,214
Deferred Inflows of Resources	
Pension deferrals	6,510
Total deferred inflows of resources	6,510
Net Position	
Net investment in capital assets	19,577,901
Unrestricted	2,423,331
Total Net Position	\$ 22,001,232

The notes to the financial statements are an integral part of this statement.

Camden County, North Carolina
Statement of Revenues and Expenditures and
Changes in Fund Net Position
Proprietary Fund
For The Year Ended June 30, 2016

	Major South Camden Water & Sewer District
Operating revenues:	
Charges for Services - Water	\$ 1,049,348
Charges for Services - Sewer	373,752
Hook-up connection fees and taps	42,350
Penalties	40,800
Miscellaneous	442,298
Total Operating Revenues	1,948,548
Operating expenses:	
Reverse osmosis plant	394,928
Water distribution	399,463
Wastewater operations	249,289
Depreciation	541,905
Total operating expenses	1,585,585
Total Operating Income (Loss)	362,963
Nonoperating Revenues(Expenses):	
Interest income	6,096
Interest expense	(63,007)
Total Nonoperating Revenues (Expenses)	(56,911)
Capital Contributions	-
Transfers from other funds	1,157,000
Changes in net position	1,463,052
Net Position - Beginning of Year	20,538,180
Total net position, Ending	\$ 22,001,232

Attachment: 2015-2016 Camden County Audit (1494 : FY 15-16 Audit by Greg Allison of Thompson, Price, Scott, Adams, & Co., PA)

Camden County, North Carolina
Statement of Cash Flows
Proprietary Fund
For The Year Ended June 30, 2016

Exhibit 8

	Major
	South
	Camden
	Water &
	Sewer
	District
Cash Flows From Operating Activities:	
Cash Received from Customers/others	\$ 1,947,724
Cash paid to suppliers for goods and services	(514,874)
Cash paid to employees for services	(509,291)
Net cash provided by (used for) operating activities	923,559
Cash Flows from (use by) capital and related financing activities:	
Capital contributions	
Federal and State grants	-
Principal repayments on long-term debt	(223,424)
Acquisition of capital assets	(312,614)
Interest income	6,096
Interest expense	(63,007)
Net cash flows provided (used) by capital financing activities	(592,949)
Cash Flows from (used for) noncapital financing activities:	
Transfers in/out (net)	1,157,000
Net cash flows provided (used) by noncapital financing activities	1,157,000
Net increase (decrease) in cash and cash equivalents	1,487,610
Cash and cash equivalents, beginning of year	996,289
Cash and cash equivalents, end of year	\$ 2,483,899
Reconciliation of Operating Income (Loss) to Net Cash Provided (Used) by Operating Activities:	
Operating Income (Loss)	\$ 362,963
Adjustments to reconcile operating income to net cash provided (used) by operating activities:	
Depreciation expense	541,905
Changes in Assets and Liabilities:	
(Increase) decrease in accounts receivable	(824)
(Increase) decrease in net pension asset	28,827
Increase (decrease) in accounts payable and accrued liabilities	18,809
Increase (decrease) in net pension liability	21,838
(Increase) decrease in deferred outflows of resources for pensions	1,523
Increase (decrease) in deferred inflows of resources for pensions	(58,908)
Increase (decrease) in accrued vacation pay	7,426
Net cash provided (used) by operating activities	\$ 923,559

The notes to the financial statements are an integral part of this statement.

24

**Camden County, North Carolina
Statement of Fiduciary Net Position
June 30, 2016**

	Agency Funds
Assets	
Cash and cash equivalents	\$ <u>10,418</u>
Liabilities and Net Position	
Miscellaneous liabilities	<u>10,418</u>
Total liabilities	<u>10,418</u>
Net Position	\$ <u>-</u>

The notes to the financial statements are an integral part of this statement.

NOTES TO THE FINANCIAL STATEMENTS

CAMDEN COUNTY, NORTH CAROLINA
NOTES TO THE FINANCIAL STATEMENTS
For the Year Ended June 30, 2016

I. Summary of Significant Accounting Policies

The accounting policies of Camden County and its component units conform to generally accepted accounting principles as applicable to governments. The following is a summary of the more significant accounting policies:

A. Reporting Entity

The County, which is governed by a five-member board of commissioners, is one of the 100 counties established in North Carolina under North Carolina General Statute 153A-10. As required by generally accepted accounting principles, these financial statements present the County and its component units, legally separate entities for which the County is financially accountable. South Camden Water and Sewer District (*the District*) exists to provide and maintain a water system for the County residents within the District. The District is reported as an enterprise fund in the County's financial statements. The Camden County ABC Board (*the Board*) and Camden County TDA, which has a June 30 year-end, are presented as if they are separate proprietary funds of the County (discrete presentation). The blended presentation methods presents component units as a department or unit of the County, and offers no separate presentation as with the discrete method.

Component Unit	Reporting Method	Criteria for Inclusion	Separate Financial Statement
South Camden Water and Sewer District	Blended	Under State law [NCGS 162A-89], the County's board of commissioners also serve as the governing board for the District	None issued.
Camden County TDA	Discrete	The members of the TDA Board's governing board are appointed by the County.	Camden County Finance P.O. Box 190 Camden, NC 27921
Camden County ABC Board	Discrete	The members of the ABC Board's governing board are appointed by the County. The ABC Board is required by State statute to distribute its surpluses to the General Fund of the County	Camden County ABC Board P.O. Box 22 Camden, NC 27921

B. Basis of Presentation – Basis of Accounting

Basis of Presentation, Measurement Focus - Basis of Accounting

Government-wide Statements: The statement of net position and the statement of activities display information about the primary government (the County) and its component units. These statements include the financial activities of the overall government, except for fiduciary activities. Eliminations have been made to minimize the double counting of internal activities. These statements distinguish between the *governmental* and *business-type activities* of the County. Governmental activities generally are financed through taxes, intergovernmental revenues, and other non-exchange transactions. Business-type activities are financed in whole or in part by fees charged to external parties.

The statement of activities presents a comparison between direct expenses and program revenues for the different business-type activities of the County and for each function of the County's governmental activities. Direct expenses are those that are specifically associated with a program or function and, therefore, are clearly identifiable to a particular function. Indirect expense allocations that have been made in the funds have been reversed for the statement of activities. Program revenues include (a) fees and charges paid by the recipients of goods or services offered by the programs and (b) grants and contributions that are restricted to meeting the operational or capital requirements of a particular program. Revenues that are not classified as program revenues, including all taxes, are presented as general revenues.

Fund Financial Statements: The fund financial statements provide information about the County's funds, including its fiduciary funds and blended component units. Separate statements for each fund category – *governmental*, *proprietary*, and *fiduciary* – are presented. The emphasis of fund financial statements is on major governmental and enterprise funds, each displayed in a separate column. All remaining governmental and enterprise funds are aggregated and reported as nonmajor funds.

Proprietary fund operating revenues, such as charges for services, result from exchange transactions associated with the principal activity of the fund. Exchange transactions are those in which each party receives and gives up essentially equal values. Nonoperating revenues, such as subsidies, result from non-exchange transactions. Other non-operating items such as investment earnings are ancillary activities.

The County reports the following major governmental funds:

General Fund - This is the County's primary operating fund. It accounts for all financial resources of the general government, except those required to be accounted for in another fund.

Courthouse and Shiloh FD - This fund is used to account for the fire needs.

Special Capital Fund - This fund is used to account for the land, building, and infrastructure acquisitions.

The County reports the following major enterprise fund:

South Camden Water and Sewer District Fund: This fund is used to account for the operations of the water and sewer district within the County.

The County's non- major governmental funds are the Automation Enhancement and Preservation Fund, the Watershed Fund, the Dismal Swamp Visitor Center Fund, the South Mills VFD Fund, the Joyce Creek Drainage Fund, the Community Park Trust Fund, the Eco Dev Fund, the School Fund, the Revaluation Fund, and the Scattered Housing Grant Fund. These funds are used to report specific special revenues and capital projects.

The County reports the following fund types:

Agency Funds: Agency funds are custodial in nature and do not involve the measurement of operating results. Agency funds are used to account for assets the County holds on behalf of others. The County maintains the following Agency Funds: the Social Services Fund, which accounts for moneys deposited with the Department of Social Services for the benefit of certain individuals; the Nancy M and H. Clay Ferebee III Fund which holds donated monies by Mr. and Mrs. Ferebee to be used for the restoration of the Camden County Courthouse.

C. Measurement Focus, Basis of Accounting

In accordance with North Carolina General Statutes, all funds of the County are maintained during the year on the modified accrual basis of accounting.

Government-wide, Proprietary, and Fiduciary Fund Financial Statements - The government-wide, proprietary, and fiduciary fund financial statements are reported using the economic resources measurement focus, except for agency funds which have no measurement focus. The government-wide, proprietary fund, and fiduciary fund financial statements are reported using the accrual basis of accounting. Revenues are recorded when earned and expenses are recorded at the time liabilities are incurred, regardless of when the related cash flows take place. Non-exchange transactions, in which the County gives (or receives) value without directly receiving (or giving) equal value in exchange, include property taxes, grants, entitlements, and donations. On an accrual basis, revenue from property taxes is recognized in the fiscal year for which the taxes are levied. Revenue from grants, entitlements, and donations is recognized in the fiscal year in which all eligibility requirements have been satisfied.

Amounts reported as program revenues include (1) charges to customers or applicants for goods, services, or privileges provided, (2) operating grants and contributions, and (3) capital grants and contributions, including special assessments. Internally dedicated resources are reported as general revenues rather than as program revenues. Likewise, general revenues include all taxes.

Proprietary funds distinguish operating revenues and expenses from nonoperating items. Operating revenues and expenses generally result from providing services and producing and delivering goods in connection with a proprietary fund's principal ongoing operations. The principal operating revenues of the County enterprise funds are charges to customers for sales and services. The County also recognizes as operating revenue the portion of tap fees intended to recover the cost of connecting new customers to the water and sewer system. Operating expenses for enterprise funds include the cost of sales and services, administrative expenses, and depreciation on capital assets. All revenues and expenses not meeting this definition are reported as nonoperating revenues and expenses.

Governmental Fund Financial Statements - Governmental funds are reported using the current financial resources measurement focus and the modified accrual basis of accounting. Under this method, revenues are recognized when measurable and available.

Expenditures are recorded when the related fund liability is incurred, except for principal and interest on general long-term debt, claims and judgments, and compensated absences, which are recognized as expenditures to the extent they have matured. General capital asset acquisitions are reported as expenditures in governmental funds. Proceeds of general long-term debt and acquisitions under capital leases are reported as other financing sources.

The County considers all revenues available if they are collected within 90 days after year-end, except for property taxes. Ad valorem property taxes are not accrued as a revenue because the amount is not susceptible to accrual. At June 30, taxes receivable for property other than motor vehicles are materially past due and are not considered to be an available resource to finance the operations of the current year. As of September 1, 2013, State law altered the procedures for the assessment and collection of property taxes on registered motor vehicles in North Carolina. Effective with this change in the law, the State of North Carolina is responsible for billing and collecting the property taxes on registered motor vehicles on behalf of all municipalities and special tax districts. Property taxes are due when vehicles are registered. The billed taxes are applicable to the fiscal year in which they are received. Uncollected taxes that were billed in periods prior to September 1, 2013 and for limited registration plates are shown as a receivable in these financial statements and are offset by deferred inflows of resources.

Sales taxes and certain intergovernmental revenues, such as the beer and wine tax, collected and held by the State at year-end on behalf of the County, are recognized as revenue. Intergovernmental revenues and sales and services are not susceptible to accrual because generally they are not measurable until received in cash. All taxes, including those dedicated for specific purposes are reported as general revenues rather than program revenues. Expenditure-driven grants are recognized as revenue when the qualifying expenditures have been incurred and all other grant requirements have been satisfied.

Under the terms of grant agreements, the County funds certain programs by a combination of specific cost-reimbursement grants, categorical block grants, and general revenues. Thus when program expenses are incurred, there are both restricted and unrestricted net position available to finance the program. It is the County's policy to first apply cost-reimbursement grant resources to such programs, followed by categorical block grants, and then by general revenues.

D. Budgetary Data

The County's budgets are adopted as required by the North Carolina General Statutes. An annual budget is adopted for the General Fund, Fire Districts, and Special Capital Fund, and the Enterprise Funds. All annual appropriations lapse at the fiscal year-end. Project ordinances are adopted for Capital Projects Fund and the Enterprise Capital Projects Funds, which are consolidated with the enterprise operating fund for reporting purposes. All budgets are prepared using the modified accrual basis of accounting. Expenditures may not legally exceed appropriations at the functional level for all annually budgeted funds and at the project level for multi-year funds. Amendments are required for revisions that alter total expenditures of any fund or that change functional appropriations by more than \$5,000. The governing board must approve all amendments. During the year, several material amendments to the original budget were necessary. The budget ordinance must be adopted by July 1 of the fiscal year or the governing board must adopt an interim budget that covers that time until the annual ordinance can be adopted.

E. Assets, Liabilities, Deferred Outflow/Inflows of Resources and Fund Equity

1. Deposits and Investments

All deposits of the County, Camden County TDA, and Camden County ABC Board are made in board-designated official depositories and are secured as required by G.S. 159-31. The County, the TDA, and the ABC Board may designate, as an official depository, any bank or savings association whose principal office is located in North Carolina. Also, the County, the TDA, and the ABC Board may establish time deposit accounts such as NOW and SuperNOW accounts, money market accounts, and certificates of deposit.

State Law [G.S. 159-30(c)] authorizes the County, Camden County TDA, and the ABC Board to invest in obligations of the United States or obligations fully guaranteed both as to principal and interest by the United States; obligations of the State of North Carolina; bonds and notes of any North Carolina local government or public authority; obligations of certain non-guaranteed federal agencies; certain high quality issues of commercial paper and bankers' acceptances; and the North Carolina Capital Management Trust (NCCMT).

The County, Camden County TDA, and the ABC Board's investments with a maturity of more than one year at acquisition and non-money market investments are reported at fair values as determined by quoted market prices. The securities of the NCCMT Cash Portfolio, an SEC registered (2a-7) money market mutual fund, are valued at fair value, which is the NCCMT's share price. The NCCMT Term Portfolio's securities are valued at fair value.

2. Cash and Cash Equivalents

The County and the TDA pool moneys from several funds to facilitate disbursement and investment and to maximize investment income. Therefore, all cash and investments are essentially demand deposits and are considered cash and cash equivalents. The ABC Board considers demand deposits and investments purchased with an original maturity of three months or less, which are not limited as to use, to be cash and cash equivalents.

3. Restricted Assets

Money in the School Capital Projects Fund is classified as restricted assets because its use is restricted per North Carolina General Statute 159-18 through 22.

4. Ad Valorem Taxes Receivable

In accordance with State law [G.S. 105-347 and G.S. 159-13(a)], the County levies ad valorem taxes on property other than motor vehicles on July 1, the beginning of the fiscal year. The taxes are due on September 1 (lien date); however, penalties and interest do not accrue until the following January 6. These taxes are based on the assessed values as of January 1, 2015. As allowed by State law, the County has established a schedule of discounts that apply to taxes, which are paid prior to the due date. In the County's General Fund, ad valorem tax revenues are reported net of such discounts.

5. Allowance for Doubtful Accounts

All receivables that historically experience uncollectible accounts are shown net of an allowance for doubtful accounts. This amount is estimated by analyzing the percentage of receivables that were written off in prior years.

6. Inventories and Prepaid Items

The inventories of the ABC Board are valued at cost (first-in, first-out), which approximates market. The inventory of the ABC Board consists of materials and supplies held for consumption or resale. The cost of the inventory carried by the ABC Board is recorded as an expense as it is consumed or sold.

Certain payments to vendors reflect costs applicable to future accounting periods and are recorded as prepaid items in both government-wide and fund financial statements.

7. Capital Assets

Purchased or constructed capital assets are reported at cost or estimated historical cost. Donated capital assets are recorded at their estimated fair value at the date of donation. Minimum capitalization cost is \$3,000 for all capital assets. Donated capital assets received prior to June 15, 2015 are recorded at their estimated fair value at the date of donation. Donated capital assets received after June 15, 2015 are recorded at acquisition value. All other purchased or constructed capital assets are reported at cost or estimated historical cost. The costs of normal maintenance and repairs that do not add to the value of the asset or materially extend assets' lives are not capitalized.

The County holds title to certain Camden County Board of Education properties that have not been included in the County's capital assets. The properties have been deeded to the County to permit installment purchase financing of acquisition and construction costs and to permit the County to receive refunds of sales tax paid for construction costs. Agreements between the County and the Board of Education give the Board of Education full use of the facilities, full responsibility for maintenance of the facilities, and provide that the County will convey title to the property back to the Board of Education, once all restrictions of the financing agreements and all sales tax reimbursement requirements have been met. The properties are reflected as capital assets in the financial statements of the Camden County Board of Education.

Capital assets of the County are depreciated on a straight-line basis over the following estimated useful lives:

<u>Asset Class</u>	<u>Years</u>
Buildings	30
Improvements	25
Plant and Distribution	40
Furniture and equipment	10
Vehicles	5-10
Computer equipment	10

Capital assets of the ABC Board are depreciated over their useful lives on a straight-line basis as follows:

<u>Asset Class</u>	<u>Years</u>
Buildings	25
Furniture & Equipment	5-10

8. Deferred outflows/inflows of resources

In addition to assets, the statement of financial position will sometimes report a separate section for deferred outflow of resources. This separate financial statement element, *Deferred Outflows of Resources*, represents a consumption of net position that applies to a future period and so will not be recognized as an expense or expenditure until then. The County has one item that meets this criterion, contributions made to the pension plan in the current fiscal year.

In addition to liabilities, the statement of financial position can also report a separate section for deferred inflows of resources. This separate financial statement element, *Deferred Inflows of Resources*, represents an acquisition of net position that applies to a future period and so will not be recognized as revenue until then. The County has only two items that meet the criterion for this category - prepaid taxes and deferrals of pension expense that result from the implementation of GASB Statement 68.

9. Long-term Obligations

In the government-wide financial statements and in the proprietary fund types in the fund financial statements, long-term debt and other long-term obligations are reported as liabilities in the applicable governmental activities, business-type activities, or proprietary fund type statement of net position.

In the fund financial statements for governmental fund types, the face amount of debt issued is reported as an other financing source.

10. Compensated Absences

The vacation policies of the County, and the ABC Board, generally provides for the accumulation of up to 240 hours earned vacation leave with such leave being fully vested when earned. For the County's government-wide and proprietary funds, and the ABC Board, an expense and a liability for compensated absences and the salary-related payments are recorded as leave as earned. The TDA has no employees.

The sick leave policies of the County and the ABC Board provide for an unlimited accumulation of earned sick leave. Sick leave does not vest, but any unused sick leave accumulated at the time of retirement may be used in the determination of length of service for retirement benefit purposes. Since none of the entities have any obligation for the accumulated sick leave until it is taken, no accrual for sick leave has been made by the County or its component unit.

11. Restricted Assets

Money in the School Capital Projects Fund is classified as restricted assets because its use is restricted per North Carolina General Statute 159-18 through 22.

School Capital Projects Fund	
Monies	\$ 249,772
Total	<u>\$ 249,772</u>

12. Net Position/Fund Balances

Net Position

Net position in government-wide and proprietary fund financial statements are classified as net investment in capital assets; restricted; and unrestricted. Restricted net position represent constraints on resources that are either a) externally imposed by creditors, grantors, contributors, or laws or regulations of other governments or b) imposed by law through state statute.

Fund Balances

In the governmental fund financial statements, fund balance is composed of five classifications designed to disclose the hierarchy of constraints placed on how fund balance can be spent.

The governmental fund types classify fund balances as follows:

Nonspendable Fund Balance - This classification includes amounts that cannot be spent because they are either (a) not in spendable form or (b) legally or contractually required to be maintained intact.

Restricted Fund Balance - This classification includes amounts that are restricted to specific purposes externally imposed by creditors or imposed by law.

Restricted for Stabilization by State statute - portion of fund balance that is restricted by State Statute [G.S. 159-8(a)]

Restricted for School Capital- portion of fund balance that can only be used for School Capital per G.S. [159-18-22].

Committed Fund Balance - portion of fund balance that can only be used for specific purposes imposed by majority vote by quorum of Camden County's governing body (highest level of decision-making authority). The governing body can, by adoption of an ordinance prior to the end of the fiscal year, commit fund balance. Once adopted, the limitation imposed by the ordinance remains in place until a similar action is taken (the adoption of another ordinance) to remove or revise the limitation.

Committed for Tax Revaluation- portion of fund balance that can only be used for Tax Revaluation.

Assigned Fund Balance - portion of fund balance that the County intends to use for specific purposes.

Unassigned Fund Balance - the portion of fund balance that has not been restricted, committed, or assigned to specific purposes or other funds.

Camden County has also adopted a minimum fund balance policy for the general fund which instructs management to conduct the business of the County in such a manner that available fund balance is at least equal to or greater than 20% of budgeted expenditures. Any portion of the general fund balance in excess of 25% of budgeted expenditures may be appropriated for one-time expenditures and may not be used for any purpose that would obligate the County in a future budget.

The County of Camden has a revenue spending policy that provides guidance for programs with multiple revenue sources. The Finance Officer will use resources in the following hierarchy: bond proceeds, federal funds, State funds, local non-county funds, county funds. For purposes of fund balance classification expenditures are to be spent from restricted fund balance first, followed in-order by committed fund balance, assigned fund balance and lastly unassigned fund balance. The Finance Officer has the authority to deviate from this policy if it is in the best interest of the County.

13. Defined Benefit Pension Plans

The County participates in three cost-sharing, multiple-employer, defined benefit pension plans that are administered by the State; the Local Governmental Employees' Retirement System (LGERS) and the Register of Deeds' Supplemental Pension Fund (RODSPF) (collectively, the "state-administered defined benefit pension plans"). For purposes of measuring the net pension asset, deferred outflows of resources and deferred inflows of resources related to pensions, and pension expense, information about the fiduciary net positions of the state-administered defined benefit pension plans and additions to/deductions from the state-administered defined benefit pension plans' fiduciary net positions have been determined on the same basis as they are reported by the state-administered defined benefit pension plans. For this purpose, plan member contributions are recognized in the period in which the contributions are due. The County's employer contributions are recognized when due and the County has a legal requirement to provide the contributions. Benefits and refunds are recognized when due and payable in accordance with the terms of the state-administered defined benefit pension plans. Investments are reported at fair value.

Reconciliation of Government-wide & Fund Financial Statements**1. Explanation of certain differences between the governmental fund balance sheet and the government-wide statement of net position**

The governmental fund balance sheet includes a reconciliation between fund balance-total governmental funds and net position-governmental activities as reported in the government-wide statement of net position. The net adjustment of \$2,581,131 consists of the following elements as follows:

<u>Description</u>	<u>Amount</u>
Capital assets used in governmental activities are not financial resources and therefore not reported in the funds (total capital assets on government-wide statement in governmental activities column)	\$ 21,025,526
Less accumulated depreciation	<u>(6,844,153)</u>
Net capital assets	14,181,373
Net pension asset.	22,073
Contributions to the pension plan in the current fiscal year are deferred outflows of resources on the Statement of Net Position.	239,261
Liabilities for deferred inflows of resources reported in the fund statements but not the government-wide	273,398
Accrued interest receivable less the amount claimed as unearned revenue in the government-wide statements as these funds are unavailable in the fund statements	90,223
Other assets not available for current expenditures	-
Pension related deferrals.	(107,360)
Liabilities that, because they are not due and payable in the current period, do not require current resources to pay and are therefore not recorded in the fund statements:	
Long-term debts, including bonds and notes payable	(11,198,273)
Accrued interest payable	(93,420)
Net pension liability	(196,545)
OPEB payable	(431,861)
Compensated absences	<u>(197,738)</u>
Total adjustment	<u>\$ 2,581,131</u>

2. Explanation of certain differences between the governmental fund statement of revenues, expenditures, and changes in fund balance and the government-wide statement of activities.

The governmental fund statement of revenues, expenditures, and changes in fund balances includes a reconciliation between net changes in fund balances-total governmental funds and changes in net assets of governmental activities as reported in the government-wide statement of activities. There are several elements of that total adjustment of \$1,023,478 as follows:

<u>Description</u>	<u>Amount</u>
Capital outlay expenditures recorded in the fund statements but capitalized as assets in the Statement of Activities	\$ 1,198,963
Depreciation expense, the allocation of those assets over their useful lives, that is recorded on the Statement of Activities but not in the fund statements	(644,179)
Cost of asset disposed of during the year	30,620
Principal payments on debt owed are recorded as a use of funds on the fund statements but again affect only the statement of net position in the government-wide statements	546,691
Contributions to the pension plan in the current fiscal year are not included on the Statement of Activities	190,683
Revenues in the statement of activities that do not provide current financial resources are not reported as revenues in fund statements	
Increase/Decrease in deferred inflows of resources- taxes receivable- at year end	(116,836)
Expenses reported in the Statement of Activities that do not require the use of current resources to pay are not recorded as expenditures in the fund statements. This includes accrued interest payable, compensated absences, pension expense and OPEB.	<u>(182,464)</u>
Total adjustment	<u>\$ 1,023,478</u>

II. Stewardship, Compliance, and Accountability

A. Significant Violations of Finance-Related Legal and Contractual Provisions

Noncompliance with North Carolina General Statutes

None.

B. Deficit Fund Balance or Net Position of Individual Funds

None.

C. Excess of Expenditures over Appropriations

None.

III. Detail Notes on All Funds

A. Assets

1. Deposits

All of the County's, TDA's, and the ABC Board's deposits are either insured or collateralized by using one of two methods. Under the Dedicated Method, all deposits exceeding the federal depository insurance coverage level are collateralized with securities held by the County's, TDA's, or the ABC Board's agents in these units' names. Under the Pooling Method, which is a collateral pool, all uninsured deposits are collateralized with securities held by the State Treasurer's agent in the name of the State Treasurer. Since the State Treasurer is acting in a fiduciary capacity for the County, TDA, and the ABC Board, these deposits are considered to be held by their agent in the entities' name. The amount of the pledged collateral is based on an approved averaging method for non-interest bearing deposits and the actual current balance for interest-bearing deposits. Depositories using the Pooling Method report to the State Treasurer the adequacy of their pooled collateral covering uninsured deposits. The State Treasurer does not confirm this information with the County or the ABC Board, or with the escrow agent. Because of the inability to measure the exact amount of collateral pledged for the County, TDA, or the ABC Board under the Pooling Method, the potential exists for the under collateralization, and this risk may increase in periods of high cash flows. However, the State Treasurer of North Carolina enforces strict standards of financial stability for each depository that collateralizes public deposits under the Pooling Method.

The State Treasurer enforces standards of minimum capitalization for all pooling method financial institutions. The County relies on the State Treasurer to monitor those financial institutions. The County analyzes the financial soundness of any other financial institution used by the County. The County complies with the provisions of G.S. 159-31 when designating official depositories and verifying that deposits are properly secured. The TDA and ABC Board have no formal policy regarding custodial credit risk for deposits.

At June 30, 2016, the County's deposits had a carrying amount of \$13,186,832 and a bank balance of \$13,462,388. Of the bank balance, \$1,376,577 was covered by federal depository insurance, the remainder was covered by the pooling method.

At June 30, 2016, Camden County had a carrying and bank balance amount of \$10,418 in the fiduciary fund.

At June 30, 2016, Camden County had \$705 of cash on hand.

At June 30, 2016, the carrying amount of deposits for Camden County ABC Board was \$102,865. All of these amounts were covered by federal depository insurance.

At June 30, 2016, the carrying amount of deposits for Camden County TDA was \$94,340. All of these amounts were covered by federal depository insurance.

2. Investments

As of June 30, 2016, the County's investments consisted of \$656,547 in the North Carolina Capital Management Trust's Cash Portfolio which carried a credit rating of AAAm by Standard and Poor's. The County has no formal policy on credit risk. The ABC Board held no investments at June 30, 2016.

3. Property Tax - Use-Value Assessment on Certain Lands

In accordance with the general statutes, agriculture, horticulture, and forestland may be taxed by the County at the present-use value as opposed to market value. When the property loses its eligibility for use-value taxation, the property tax is recomputed at market value for the current year and the two preceding fiscal years, along with the accrued interest from the original due date. This tax is immediately due and payable. The following are property taxes that could become due if present-use value eligibility is lost. These amounts have not been recorded in the financial statements.

Year Levied	Tax	Interest	Total
2013	\$ 1,332,752	\$ 196,581	\$ 1,529,333
2014	1,291,174	-	1,291,174
2015	-	-	-
Total	\$ 2,623,926	\$ 196,581	\$ 2,820,507

4. Receivables

Receivables at the government-wide level at June 30, 2016 were as follows:

	Accounts	Taxes & Related Accrued Interest	Due From Other Governments	Total
Governmental Activities:				
General	\$ 56,347	\$ 483,507	\$ 165,227	\$ 705,081
Other Governmental	-	4,114	296,607	300,721
Total Receivables	56,347	487,621	-	543,968
Allowance for Doubtful	-	(124,000)	-	(124,000)
Total Governmental	\$ 56,347	\$ 363,621	\$ 461,834	\$ 881,802
Business-Type Activities:				
Water/Sewer receivables	\$ 149,337	\$ -	\$ -	\$ 149,337
Allowance for Doubtful Accounts	-	-	-	-
Total Business-Type	\$ 149,337	\$ -	\$ -	\$ 149,337

Notes to the Financial Statements

5. Capital Assets**Primary Government**

Capital asset activity for the year ended June 30, 2016, was as follows:

	Beginning Balances		Ending Balances	
	July 1, 2015	Increases	Decreases	June 30, 2016
Governmental Activities:				
Capital assets not being depreciated:				
Land	\$ 5,015,871	\$ -	\$ -	\$ 5,015,871
Construction in Progress	447,790	-	(447,790)	-
Total capital assets not being depreciated	5,463,661	-	(447,790)	5,015,871
Capital assets being depreciated:				
Buildings	5,712,475	53,161	-	5,765,636
Other improvements	4,526,821	498,887	-	5,025,708
Equipment	1,608,681	355,039	-	1,963,720
Vehicles and motor equipment	2,657,703	739,666	(142,778)	3,254,591
Total capital assets being depreciated	14,505,680	1,646,753	(142,778)	16,009,655
Less accumulated depreciation for:				
Buildings	2,003,336	206,376	-	2,209,712
Other improvements	1,105,584	143,890	-	1,249,474
Equipment	998,969	69,309	-	1,068,278
Vehicles and motor equipment	2,221,049	224,604	(128,964)	2,316,689
Total accumulated depreciation	6,328,938	\$ 644,179	\$ (128,964)	6,844,153
Total capital assets being depreciated, net	8,176,742			9,165,502
Governmental activity capital assets, net	\$ 13,640,403			\$ 14,181,373

Notes to the Financial Statements

Depreciation expense was charged to functions/programs of the primary government as follows:

General government	\$ 140,639
Public Safety	309,170
Environmental Protection	7,397
Economic and Physical Development	42,187
Human Services	43,580
Cultural and Recreational	101,206
Total Depreciation Expense	<u>\$ 644,179</u>

	Beginning Balances	Increases	Decreases	Ending Balances
Business-type Activities				
Water & Sewer District				
Capital assets not being depreciated:				
Land	\$ 768,380	\$ 282,014	\$ -	\$ 1,050,394
Construction in progress	-	30,600	-	30,600
Total capital assets not being depreciated	<u>768,380</u>	<u>312,614</u>	<u>-</u>	<u>1,080,994</u>
Capital assets being depreciated:				
Plant and distribution systems	26,198,364	-	-	26,198,364
Furniture and equipment	88,095	-	-	88,095
Vehicles and motor equipment	129,228	-	-	129,228
Total capital assets being depreciated	<u>26,415,687</u>	<u>-</u>	<u>-</u>	<u>26,415,687</u>
Less accumulated depreciation for:				
Plant and distribution systems	4,843,249	530,710	-	5,373,959
Furniture and equipment	62,710	2,843	-	65,553
Vehicles and motor equipment	99,630	8,351	-	107,981
Total accumulated depreciation	<u>5,005,589</u>	<u>\$ 541,904</u>	<u>\$ -</u>	<u>5,547,493</u>
Total capital assets being depreciated, net	<u>21,410,098</u>			<u>20,868,194</u>
Total Water and Sewer Fund District, Net	<u>\$ 22,178,478</u>			<u>\$ 21,949,188</u>

Discretely presented component unit
ABC Board:

Land	\$ 25,405
Buildings	161,798
Equipment	55,158
Construction in progress	48,446
Less A/D	(151,665)
Property and Equipment, net	<u>\$ 139,142</u>

B. Liabilities**1. Payables**

Payables at the government-wide level at June 30, 2016, were as follows:

	Vendors	Accrued Interest	Total
Governmental Activities	\$ 426,256	\$ 93,420	\$ 519,676
Business-type Activities	\$ 63,461	\$ 20,896	\$ 84,357

2. Pension Plan and Other Post Employment Obligations**a. Local Governmental Employees' Retirement System**

Plan Description. Camden County and the ABC Board are participating employers in the statewide Local Governmental Employees' Retirement System (LGERS), a cost-sharing multiple-employer defined benefit pension plan administered by the State of North Carolina. LGERS membership is comprised of general employees and local law enforcement officers (LEOs) of participating local governmental entities. Article 3 of G.S. Chapter 128 assigns the authority to establish and amend benefit provisions to the North Carolina General Assembly. Management of the plan is vested in the LGERS Board of Trustees, which consists of 13 members – nine appointed by the Governor, one appointed by the state Senate, one appointed by the state House of Representatives, and the State Treasurer and State Superintendent, who serve as ex-officio members. The Local Governmental Employees' Retirement System is included in the Comprehensive Annual Financial Report (CAFR) for the State of North Carolina. The State's CAFR includes financial statements and required supplementary information for LGERS. That report may be obtained by writing to the Office of the State Controller, 1410 Mail Service Center, Raleigh, North Carolina 27699-1410, by calling (919) 981-5454, or at www.osc.nc.gov.

Benefits Provided. LGERS provides retirement and survivor benefits. Retirement benefits are determined as 1.85% of the member's average final compensation times the member's years of creditable service. A member's average final compensation is calculated as the average of a member's four highest consecutive years of compensation. Plan members are eligible to retire with full retirement benefits at age 65 with five years of creditable service, at age 60 with 25 years of creditable service, or at any age with 30 years of creditable service. Plan members are eligible to retire with partial retirement benefits at age 50 with 20 years of creditable service or at age 60 with five years of creditable service (age 55 for firefighters). Survivor benefits are available to eligible beneficiaries of members who die while in active service or within 180 days of their last day of service and who have either completed 20 years of creditable service regardless of age (15 years of creditable service for firefighters and rescue squad members who are killed in the line of duty) or have completed five years of service and have reached age 60. Eligible beneficiaries may elect to receive a monthly Survivor's Alternate Benefit for life or a return of the member's contributions. The plan does not provide for automatic postretirement benefit increases. Increases are contingent upon actuarial gains of the plan.

LGERS plan members who are LEOs are eligible to retire with full retirement benefits at age 55 with five years of creditable service as an officer, or at any age with 30 years of creditable service. LEO plan members are eligible to retire with partial retirement benefits at age 50 with 15 years of creditable service as an officer. Survivor benefits are available to eligible beneficiaries of LEO members who die while in active service or within 180 days of their last day of service and who also have either completed 20 years of creditable service regardless of age, or have completed 15 years of service as a LEO and have reached age 50, or have completed five years of creditable service as a LEO and have reached age 55, or have completed 15 years of creditable service as a LEO if killed in the line of duty. Eligible beneficiaries may elect to receive a monthly Survivor's Alternate Benefit for life or a return of the member's contributions.

Contributions. Contribution provisions are established by General Statute 128-30 and may be amended only by the North Carolina General Assembly. County employees are required to contribute 6% of their compensation. Employer contributions are actuarially determined and set annually by the LGERS Board of Trustees. The County's contractually required contribution rate for the year ended June 30, 2016, was 7.41% of compensation for law enforcement officers and 7.07% for general employees and firefighters, actuarially determined as an amount that, when combined with employee contributions, is expected to finance the costs of benefits earned by employees during the year. Contributions to the pension plan from the County were \$208,510 for the year ended June 30, 2016.

Refunds of Contributions – County employees who have terminated service as a contributing member of LGERS, may file an application for a refund of their contributions. By state law, refunds to members with at least five years of service include 4% interest. State law requires a 60 day waiting period after service termination before the refund may be paid. The acceptance of a refund payment cancels the individual's right to employer contributions or any other benefit provided by LGERS.

Pension Liabilities, Pension Expense, and Deferred Outflows of Resources and Deferred Inflows of Resources Related to Pensions

At June 30, 2016, the County reported a liability of \$218,383 for its proportionate share of the net pension liability. The net pension liability was measured as of June 30, 2015. The total pension liability used to calculate the net pension liability was determined by an actuarial valuation as of December 31, 2014. The total pension liability was then rolled forward to the measurement date of June 30, 2015 utilizing update procedures incorporating the actuarial assumptions. The County's proportion of the net pension asset was based on a projection of the County's long-term share of future payroll covered by the pension plan, relative to the projected future payroll covered by the pension plan of all participating LGERS employers, actuarially determined. At June 30, 2015, the County's proportion was .04866%, which was an decrease of .00022% from its proportion measured as of June 30, 2014.

For the year ended June 30, 2016, the County recognized pension expense of \$141,410. At June 30, 2016, the County reported deferred outflows of resources and deferred inflows of resources related to pensions from the following sources:

	<u>Deferred Outflows of Resources</u>	<u>Deferred Inflows of Resources</u>
Differences between expected and actual experience	\$ -	\$ 51,332
Net difference between projected and actual earnings on pension plan investments	-	62,173
Changes in proportion and differences between County contributions and proportionate share of contributions	45,183	-
County contributions subsequent to the measurement date	208,510	-
Total	<u>\$ 253,693</u>	<u>\$ 113,505</u>

\$208,510 reported as deferred outflows of resources related to pensions resulting from County contributions subsequent to the measurement date will be recognized as an increase of the net pension asset in the year ended June 30, 2017. Other amounts reported as deferred inflows of resources related to pensions will be recognized in pension expense as follows:

Year Ended June 30	
2017	\$ (57,978)
2018	(57,978)
2019	(58,021)
2020	105,655
2021	-
Thereafter	-
Total	<u>\$ (68,322)</u>

Actuarial Assumptions. The total pension liability in the December 31, 2014 actuarial valuation was determined using the following actuarial assumptions, applied to all periods included in the measurement:

Inflation	3.0 percent
Salary Increases	4.25 to 8.55 percent, including inflation and productivity factor
Investment rate of return	7.25 percent, net of pension plan investment expense, including inflation

The plan currently uses mortality tables that vary by age, gender, employee group (i.e. general, law enforcement officer) and health status (i.e. disabled and healthy). The current mortality rates are based on published tables and based on studies that cover significant portions of the U.S. population. The healthy mortality rates also contain a provision to reflect future mortality improvements.

The actuarial assumptions used in the December 31, 2014 valuation were based on the results of an actuarial experience study for the period January 1, 2005 through December 31, 2009.

Notes to the Financial Statements

Future ad hoc COLA amounts are not considered to be substantively automatic and are therefore not included in the measurement.

The projected long-term investment returns and inflation assumptions are developed through review of current and historical capital markets data, sell-side investment research, consultant whitepapers, and historical performance of investment strategies. Fixed income return projections reflect current yields across the U.S. Treasury yield curve and market expectations of forward yields projected and interpolated for multiple tenors and over multiple year horizons. Global public equity return projections are established through analysis of the equity risk premium and the fixed income return projections. Other asset categories and strategies' return projections reflect the foregoing and historical data analysis. These projections are combined to produce the long-term expected rate of return by weighting the expected future real rates of return by the target asset allocation percentage and by adding expected inflation. The target allocation and best estimates of arithmetic real rates of return for each major asset class as of June 30, 2015 are summarized in the following table:

Asset Class	Target Allocation	Long-Term Expected Real Rate of Return
Fixed Income	29.0%	2.2%
Global Equity	42.0%	5.8%
Real Estate	8.0%	5.2%
Alternatives	8.0%	9.8%
Credit	7.0%	6.8%
Inflation	6.0%	3.4%
Total	100%	

The information above is based on 30 year expectations developed with the consulting actuary for the 2014 asset liability and investment policy study for the North Carolina Retirement Systems, including LGERS. The long-term nominal rates of return underlying the real rates of return are arithmetic annualized figures. The real rates of return are calculated from nominal rates by multiplicatively subtracting a long-term inflation assumption of 3.00%. All rates of return and inflation are annualized.

Discount rate. The discount rate used to measure the total pension liability was 7.25%. The projection of cash flows used to determine the discount rate assumed that contributions from plan members will be made at the current contribution rate and that contributions from employers will be made at statutorily required rates, actuarially determined. Based on these assumptions, the pension plan's fiduciary net position was projected to be available to make all projected future benefit payments of the current plan members. Therefore, the long-term expected rate of return on pension plan investments was applied to all periods of projected benefit payments to determine the total pension liability.

Sensitivity of the County's proportionate share of the net pension asset to changes in the discount rate. The following presents the County's proportionate share of the net pension asset calculated using the discount rate of 7.25 percent, as well as what the County's proportionate share of the net pension asset or net pension liability would be if it were calculated using a discount rate that is 1-percentage-point lower (6.25 percent) or 1-percentage-point higher (8.25 percent) than the current rate:

	1 % Decrease (6.25%)	Discount Rate (7.25%)	1% Increase (8.25%)
County's proportionate share of the net pension liability (asset)	\$1,522,815	\$218,383	(\$880,572)

Pension plan fiduciary net position. Detailed information about the pension plan's fiduciary net position is available in the separately issued Comprehensive Annual Financial Report (CAFR) for the State of North Carolina.

b. Law Enforcement Officers Special Separation Allowance

(1) Plan Description - Camden County administers a public employee retirement system (the "Separation Allowance"), a single-employer defined benefit pension plan that provides retirement benefits to the County's qualified sworn law enforcement officers. The Separation allowance is equal to .85 percent of the annual equivalent of the base rate of compensation most recently applicable to the officer for each year of creditable service. The retirement benefits are not subject to any increases in salary or retirement allowances that may be authorized by the General Assembly. Article 12D of G.S. Chapter 143 assigns the authority to establish and amend benefit provisions to the North Carolina General Assembly.

All full-time County law enforcement officers are covered by the Separation Allowance. At the December 31, 2015, the Separation Allowance's membership consisted of:

Retirees Receiving Benefits	-
Terminated Plan Members Entitled to, But Not Yet Receiving Benefits	-
Active Plan Members	<u>15</u>
Total	<u><u>15</u></u>

A separate report was not issued for the plan.

(2) Summary of Significant Accounting Policies

Basis of Accounting - The County has chosen to fund the Separation Allowance on a pay as you go basis. Pension expenditures are made from the General Fund, which is maintained on the modified accrual basis of accounting.

Method Used to Value Investments - No funds are set aside to pay benefits and administration costs. These expenditures are paid as they come due. No liability is reported on the Statement of Net Assets due to the amount not being material.

(3) Contributions

The County is required by article 12D of G.S. Chapter 143 to provide these retirement benefits and has chosen to fund the benefit payments on a pay as you go basis through appropriations made in the General Fund operating budget. The County's obligation to contribute to this plan is established and may be amended by the North Carolina General Assembly. There were no contributions made by employees.

c. Supplemental Retirement Income Plan for Law Enforcement Officers

Plan Description - The County contributes to the Supplemental Retirement Income Plan (Plan), a defined contribution pension plan administered by the Department of the State Treasurer and a Board of Trustees. The Plan provides retirement benefits to law enforcement officers employed by the County. Article 5 of G.S. Chapter 135 assigns the authority to establish and amend benefit provisions to the North Carolina General Assembly. The State's CAFR includes the pension trust fund financial statements for the Internal Revenue Code Section 401(k) plan that includes the Supplemental Retirement Income Plan for Law Enforcement Officers. That report may be obtained by writing to the Office of the State Controller, 1410 Mail Service Center, Raleigh, North Carolina 27699-1410, or by calling (919) 981-5454.

Funding Policy - Article 12E of G.S. Chapter 143 requires the County to contribute each month an amount equal to five percent of each officer's salary, and all amounts contributed are vested immediately. Also, the law enforcement officers may make voluntary contributions to the plan. Contributions for the year ended June 30, 2016 were \$235,254, which consisted of \$160,240 from the County and \$75,014 from the law enforcement officers.

d. Register of Deeds' Supplemental Pension Fund

Plan Description. Camden County also contributes to the Registers of Deeds' Supplemental Pension Fund (RODSPF), a noncontributory, defined benefit plan administered by the North Carolina Department of State Treasurer. RODSPF provides supplemental pension benefits to any eligible county register of deeds who is retired under the Local Government Employees' Retirement System (LGERS) or an equivalent locally sponsored plan. Article 3 of G.S. Chapter 161 assigns the authority to establish and amend benefit provisions to the North Carolina General Assembly. Management of the plan is vested in the LGERS Board of Trustees, which consists of 13 members – nine appointed by the Governor, one appointed by the state Senate, one appointed by the state House of Representatives, and the State Treasurer and State Superintendent, who serve as ex-officio members. The Registers of Deeds' Supplemental Pension Fund is included in the Comprehensive Annual Financial Report (CAFR) for the State of North Carolina. The State's CAFR includes financial statements and required supplementary information for the Registers of Deeds' Supplemental Pension Fund. That report may be obtained by writing to the Office of the State Controller, 1410 Mail Service Center, Raleigh, North Carolina 27699-1410, by calling (919) 981-5454, or at www.osc.nc.gov.

Benefits Provided. An individual's benefits for the year are calculated as a share of accumulated contributions available for benefits for that year, subject to certain statutory limits. An individual's eligibility is based on at least 10 years of service as a register of deeds with the individual's share increasing with years of service. Because of the statutory limits noted above, not all contributions available for benefits are distributed.

Contributions. Benefits and administrative expenses are funded by investment income and 1.5% of the receipts collected by each County Commission under Article 1 of Chapter 161 of the North Carolina General Statutes. The statutory contribution currently has no relationship to the actuary's required contribution. The actuarially determined contribution this year and for the foreseeable future is zero. Registers of Deeds do not contribute. Contribution provisions are established by General Statute 161-50 and may be amended only by the North Carolina General Assembly. Contributions to the pension plan from the County were \$3,024 for the year ended June 30, 2016.

Pension Liabilities, Pension Expense, and Deferred Outflows of Resources and Deferred Inflows of Resources Related to Pensions

At June 30, 2016, the County reported an asset of \$22,073 for its proportionate share of the net pension asset. The net pension asset was measured as of June 30, 2015. The total pension liability used to calculate the net pension asset was determined by an actuarial valuation as of December 31, 2014. The total pension liability was then rolled forward to the measurement date of June 30, 2015 utilizing update procedures incorporating the actuarial assumptions. The County's proportion of the net pension asset was based on the County's share of contributions to the pension plan, relative to contributions to the pension plan of all participating RODSPF employers. At June 30, 2015, the County's proportion was .09522%, which was a decrease of .00582% from its proportion measured as of June 30, 2014.

For the year ended June 30, 2016, the County recognized pension expense of \$741. At June 30, 2016, the County reported deferred outflows of resources and deferred inflows of resources related to pensions from the following sources:

	Deferred Outflows of	
	Resources	Deferred Inflows of Resources
Differences between expected and actual experience	\$ 108	\$ 365
Net difference between projected and actual earnings on pension plan investments	1,095	-
Changes in proportion and differences between County contributions and proportionate share of contributions	1,873	-
County contributions subsequent to the measurement date	3,024	
Total	\$ 6,100	\$ 365

\$3,024 reported as deferred outflows of resources related to pensions resulting from County contributions subsequent to the measurement date will be recognized as an increase of the net pension asset in the year ended June 30, 2017. Other amounts reported as deferred inflows of resources related to pensions will be recognized in pension expense as follows:

Year Ended June 30	
2017	\$ 904
2018	904
2019	903
2020	-
2021	-
Total	<u>\$ 2,711</u>

Actuarial Assumptions. The total pension liability in the December 31, 2014 actuarial valuation was determined using the following actuarial assumptions, applied to all periods included in the measurement:

Inflation	3.0 percent
Salary Increases	4.25 to 7.75 percent, including inflation and productivity factor
Investment rate of return	5.75 percent, net of pension plan investment expense, including inflation

The plan currently uses mortality tables that vary by age, gender, employee group (i.e. general, law enforcement officer) and health status (i.e. disabled and healthy). The current mortality rates are based on published tables and based on studies that cover significant portions of the U.S. population. The healthy mortality rates also contain a provision to reflect future mortality improvements.

The actuarial assumptions used in the December 31, 2014 valuation were based on the results of an actuarial experience study for the period January 1, 2005 through December 31, 2009.

Future ad hoc COLA amounts are not considered to be substantively automatic and are therefore not included in the measurement.

The projected long-term investment returns and inflation assumptions are developed through review of current and historical capital markets data, sell-side investment research, consultant whitepapers, and historical performance of investment strategies. Fixed income return projections reflect current yields across the U.S. Treasury yield curve and market expectations of forward yields projected and interpolated for multiple tenors and over multiple year horizons. These projections are combined to produce the long-term expected rate of return by weighting the expected future real rates of return by the target asset allocation percentage and by adding expected inflation. The adopted asset allocation policy for the RODSPF is 100% in the fixed income asset class. The best estimate of arithmetic real rate of return for the fixed income asset class as of June 30, 2014 is 2.5%.

The information above is based on 30 year expectations developed with the consulting actuary for the 2014 asset, liability, and investment policy study for the North Carolina Retirement Systems, including LGERS. The long-term nominal rates of return underlying the real rates of return are arithmetic annualized figures. The real rates of return are calculated from nominal rates by multiplicatively subtracting a long-term inflation assumption of 3.19%. All rates of return and inflation are annualized.

Discount rate. The discount rate used to measure the total pension liability was 5.75%. The projection of cash flows used to determine the discount rate assumed that contributions from employers will be made at statutorily required rates. Based on these assumptions, the pension plan's fiduciary net position was projected to be available to make all projected future benefit payments of the current plan members. Therefore, the long-term expected rate of return on pension plan investments was applied to all periods of projected benefit payments to determine the total pension liability.

Sensitivity of the County's proportionate share of the net pension asset to changes in the discount rate. The following presents the County's proportionate share of the net pension asset calculated using the discount rate of 5.75 percent, as well as what the County's proportionate share of the net pension asset would be if it were calculated using a discount rate that is 1-percentage-point lower (4.75 percent) or 1-percentage-point higher (6.75 percent) than the current rate:

	1 % Decrease (4.75%)	Discount Rate (5.75%)	1% Increase (6.75%)
County's proportionate share of the net pension liability (asset)	(\$20,571)	(\$22,909)	(\$24,918)

Pension plan fiduciary net position. Detailed information about the pension plan's fiduciary net position is available in the separately issued Comprehensive Annual Financial Report (CAFR) for the State of North Carolina.

e. Other Post Employment Benefits

Healthcare Benefits

Plan Description - Under the terms of the County resolution, the County administers a single-employer defined benefit Healthcare Benefits Plan (the HCB Plan). As of July 1, 2006, this plan provides postemployment healthcare benefits to retirees of the County, provided they participate in the North Carolina Local Governmental Employees' Retirement System (System) and have at least twenty years of creditable service with the County. The County pays the full cost of coverage for these benefits through private insurers. The County Board may amend the benefit provisions. A separate report was not issued for the plan. If hired after January 8, 2013 no health benefits will be paid for retirees.

Membership of the HCB Plan consisted of the following at December 31, 2015, the date of latest actuarial valuation:

	General Employees	Law Enforcement Officers
Retirees and dependents receiving benefits	-	-
Terminated plan members entitled to but not yet receiving benefits	-	-
Active plan members	38	15
Total	38	15

Funding Policy - The County pays the full cost of coverage for the healthcare benefits paid to qualified retirees under a County resolution that can be amended by the County Board. The County has chosen to fund the healthcare benefits on a pay as you go basis.

The current ARC rate is 4.01% of annual covered payroll. For the current year, the County contributed \$0. The County obtains healthcare coverage through private insurers. There were no contributions made by employees. The County's obligation to contribute to HCB Plan is established and may be amended by the County Board.

Summary of Significant Accounting Policies . Postemployment expenditures are made from the General Fund, which is maintained on the modified accrual basis of accounting. No funds are set aside to pay benefits and administration costs. These expenditures are paid as they come due.

Annual OPEB Cost and Net OPEB Obligation . The County's annual other postemployment benefit (OPEB) cost (expense) is calculated based on the *annual required contribution of the employer* (ARC), an amount actuarially determined in accordance with the parameters of GASB Statement 45. The ARC represents a level of funding that, if paid on an ongoing basis is projected to cover normal cost each year and amortize any unfunded actuarial liabilities (or funding excess) over a period not to exceed thirty years. The following table shows the components of the County's annual OPEB cost for the year, the amount actually contributed to the plan, and changes on the County's net OPEB obligation for the post employment healthcare benefits:

Annual required contribution	\$ 87,943
Interest on net OPEB obligation	14,008
Adjustment to annual required contribution	(19,473)
Annual OPEB cost (expense)	82,478
Contributions made	-
Increase (decrease) in net OPEB obligation	82,478
Net OPEB obligation, beginning of year	432,683
Net OPEB obligation, end of year	\$ 515,161

Notes to the Financial Statements

The County's annual OPEB cost, the percentage of annual OPEB cost contributed to the plan, and the net OPEB obligation for June 30, 2016 were as follows:

For Year Ended June 30	Annual OPEB Cost	Percentage of Annual OPEB Cost Contributed	Net OPEB Obligation
2014	\$ 70,429	0.00%	\$ 350,205
2015	\$ 82,478	0.00%	\$ 432,683
2016	\$ 82,478	0.00%	\$ 515,161

Funded Status and Funding Progress. As of June 30, 2016 the plan was not funded. The actuarial accrued liability for benefits and, thus, the unfunded actuarial liability (UAAL) was \$663,838. The covered payroll (annual payroll of active employees covered by the plan) was \$2,067,678, and the ratio of UAAL to the covered payroll was 32.11%. easing or decreasing over time relative to the actuarial accrued liabilities for benefits.

Actuarial valuations of an ongoing plan involve estimates of the value of reported amounts and assumptions about the probability of occurrence of events far into the future. Examples include assumptions about future employment, mortality, and the healthcare cost trend. Amounts determined regarding the funded status of the plan and the annual required contributions of the employer are subject to continual revision as actual results are compared with past expectations and new estimates are made about the future. The schedule of funding progress, presented as required supplementary information following the notes to the financial statements, presents information about the actuarial value of plan assets and the actuarially accrued liabilities for benefits.

Actuarial Methods and Assumptions. Projections of benefits for financial reporting purposes are based on the substantive plan (the plan as understood by the employer and the plan members) and include the types of benefits provided at the time of each valuation and the historical pattern of sharing of benefit costs between the employer and plan members to that point. The actuarial methods and assumptions used include techniques that are designed to reduce the effects of short-term volatility in actuarial accrued liabilities and the actuarial value assets, consistent with the long-term perspective of the calculations.

In the December 31, 2015 actuarial valuation, the projected unit credit actuarial cost method was used. The actuarial assumptions included a 4.0% investment rate of return (net of administrative expenses), which is the expected long-term investment returns on the employer's own investments calculated based on the funded level of the plan at the valuation date, and an annual medical cost trend increase of 7.50% to 5.00% annually. The investment rate included a 3.00% inflation assumption. The actuarial value of assets, if any, was determined using techniques that spread the effects of short-term volatility in the market value of investments over a five year period. The UAAL is being amortized as a level percentage of projected payroll on an open basis. The remaining amortization period at December 31, 2015, was 30 years.

f. Other Employment Benefits

The County has elected to provide death benefits to employees through the Death Benefit Plan for members of the Local Governmental Employees' Retirement System (Death Benefit Plan), a multiple-employer, State-administered, cost-sharing plan funded on a one-year term cost basis. The beneficiaries of those employees who die in active service after one year of contributing membership in the System, or who die within 180 days after retirement or termination of service and have at least one year of contributing membership service in the System at the time of death are eligible for death benefits. Lump sum death benefit payments to beneficiaries are equal to the employee's 12 highest months' salary in a row during the 24 months prior to the employee's death, but the benefit will be a minimum of \$25,000 and will not exceed \$50,000. Because all death benefit payments are made from the Death Benefit Plan and not by the County, the County does not determine the number of eligible participants. The County has no liability beyond the payment of monthly contributions. The contributions to the Death Benefit Plan cannot be separated between the post-employment benefit amount and the other benefit amount. Contributions are determined as a percentage of monthly payroll based upon rates established annually by the State. Separate rates are set for employees not engaged in law enforcement and for law enforcement officers. The County considers these contributions to be immaterial.

4. Risk Management

The County is exposed to various risks of loss related to torts; theft of, damage to, and destruction of assets; errors and omissions, injuries to employees; and natural disasters. The County participates in three self-funded risk financing pools administered by the North Carolina Association of County Commissioners. Through these pools, the County obtains property coverage equal to replacement cost values of owned property subject to a limit of \$125.5 million for any one occurrence, general, auto, professional and employment practices liability coverage of \$2 million per occurrence, auto physical damage coverage for owned autos, at actual cash value, crime coverage of \$250,000 per occurrence, workers' compensation coverage up to the statutory limits and health and dental insurance for County employees. The pools are audited annually by Certified Public Accountants, and the audited financial statements are available to the County upon request. Two of the pools are reinsured through a multi-state public entity captive for single occurrence losses in excess of \$500,000 up to a \$2 million limit for liability coverage, \$600,000 of aggregate annual losses in excess of \$50,000 per occurrence for property, auto physical damage and crime coverage, and single occurrence losses of \$350,000 for workers' compensation. For health and dental insurance, the County is insured through Blue Cross Blue Shield of North Carolina, a private insurance company.

The County carries flood insurance on the renovated courthouse. Other buildings are not insured for flood.

In accordance with G.S. 159-29, the County's employees that have access to \$100 or more at any given time of the County's funds are performance bonded through a commercial surety bond. The Finance Officer is bonded for \$550,000, the tax collector is bonded for \$50,000 and the sheriff is bonded for \$25,000. The remaining employees that have access to funds are bonded under a blanket bond for \$15,000.

There have been no significant reductions in insurance coverage from the previous year and no claims have been made in the past three years.

Camden County ABC Board is exposed to various risks of loss related to torts; theft of, damage to, and destruction of assets; errors and omissions; and natural disasters. The Board has commercial property, general liability, auto liability, workers' compensation, and employee health coverage. The Board does have liquor legal liability coverage. In accordance with G.S. 18B-803, the ABC Board's employees that have access to the Board's funds are performance bonded through a commercial surety bond. Employees are bonded under an employment practices bond for up to \$5,000 per claim. There have been no significant reductions in insurance coverage in the prior year and settled claims have not exceeded coverage in any of the past three fiscal years.

5. Contingent Liabilities

At June 30, 2016, the County was a defendant to various lawsuits. In the opinion of the County's management and the County attorney, the ultimate effect of these legal matters will not have a material adverse effect on the County's financial position.

6. Long-Term Obligations

a. Installment Purchases

As authorized by State law [G.S. 160A-20 and 153A-158.1], the County has financed various property acquisitions for use by Camden County Board of Education by installment purchase. The installment purchases were issued pursuant to a deed of trust that requires that legal title remain with the County as long as the debt is outstanding. The County has entered into a lease with Camden County Board of Education that transfers the right and responsibilities for maintenance and insurance of the property to the Board of Education. The lease calls for nominal annual lease payments and also contains a bargain purchase option. The lease term is the same as that of the installment purchase obligation. Due to the economic substance of the transaction, the capital assets associated with the installment purchase obligation are recorded by the Board of Education. These loans are included in the loans described below.

The installment purchases of the County, including the Qualified Zone Academy Bonds, are outlined below:

\$1,000,000 loan from Bank of America, N.A. for renovation and modernization of Camden High School and Camden Middle School. The note is secured by a deed of trust on the two schools and calls for an annual payments of \$50,000 plus 4.4%. This note was paid off and refinanced with a principal amount of \$572,000 and calls for annual payments of \$52,150 plus interest at 2.29%. Matures in 2024.	\$ 365,054
\$2,000,000 loan from Bank of America, N.A. (QZAB) for renovation and modernization of Camden High School and Camden Middle School. The note is secured by a deed of trust on the two schools and calls for annual payments of \$112,334 and no interest is charged. Matures in 2023.	651,992
\$264,000 loan from Rural Housing Service to finance courthouse renovations. The loan is secured by the courthouse. The note calls for annual payments of \$20,297 including interest at 4.5%. Matures in 2026.	160,571
\$453,000 loan from BB&T for the re-finance of a two pumper trucks. The loan calls for annual payments of \$48,072 including interest at 2.09%. Matures in 2021.	171,868
\$725,000 loan from BB&T dated August 16, 2010 for the construction of a Fire Station Building. The loan calls for annual payments of \$36,250 plus interest at 3.89%. Matures in 2027.	543,750
\$1,350,000 loan from Thomas M. Noblitt for the purchase of land. The loan is secured with the property. The loan calls for annual payments of \$150,000 for 9 years. There is no interest stated in the loan. Matures in 2018.	300,000
\$10,000,000 loan from US Department of Agriculture for the construction of an intermediate school. The note calls for annual payments of \$520,000 for 40 years which includes interest at 4.125%. Matures in 2049.	9,005,038
	<u>\$ 11,198,273</u>

Notes to the Financial Statements

b. General Obligation Indebtedness

All general obligation bonds serviced by the County's general fund are collateralized by the full faith, credit, and taxing power of the County. South Camden Water and Sewer District issues general obligation bonds to provide funds for the acquisition and construction of major water and sewer capital improvements. These bonds, which are recorded in the Water District Fund, are collateralized by the full faith, credit, and taxing power of the District. Principal and interest payments are appropriated when due.

The County's general obligation bonds are payable at June 30, 2016, are comprised of the following individual issues:

Serviced by South Camden Water and Sewer District:

\$1,600,000 - 1996 Water District bonds with annual installments of \$17,000 to \$66,000 through June 1, 2036; interest at 4.875%. These Bonds were refinanced with a principal amount of \$1,274,000 with annual installments of \$99,493 plus interest at 3.89%. \$ 1,098,306

Other Loans:

Drinking Water State Revolving Loan: A loan of \$813,581 calling for 20 annual principal payments of \$40,679 plus interest at 2.87% (payable semiannually). This Note was refinanced during 2013 with a principal amount of \$406,791 with varying annual installments plus interest at 2.19%. Matures in 2032. 244,074

State DWSRF Revolving Loan: A loan of \$1,367,122 calling for 20 annual principal payments of \$68,356 plus interest at 2.50%. At year end \$1,307,360 has been drawn down on the loan amount. This associated project was completed during the year and half of the outstanding principal was forgiven. The new payments will be for 20 years at \$32,684 with no stated interest rate. Matures in 2032. 522,947

State Clean Water Bond Loan: A loan of \$1,922,657 calling for 19 annual principal payments of \$101,192 plus interest at 4.02%. This Note was refinanced during 2013 with a principal amount of \$910,732 with varying annual installments plus interest at 2.09%. Matures in 2023. 505,960

Total \$ 2,371,287

Annual debt service requirements to maturity for the County's and District's general obligation bonds and loans are as follows:

Year Ending June 30,	Governmental Activities		Business Type Activities	
	Principal	Interest	Principal	Interest
2017	553,990	411,788	225,324	58,644
2018	561,577	401,597	227,299	53,663
2019	419,459	390,710	229,351	48,605
2020	427,652	380,683	231,483	43,468
2021	390,932	369,193	233,697	38,247
2022-2026	1,452,104	1,685,542	536,163	136,296
2027-2031	1,389,628	1,412,816	565,293	65,595
2032-2036	1,478,983	1,121,017	122,677	3,501
2037-2041	1,810,248	789,752	-	-
2042-2046	2,215,712	384,288	-	-
2047-2051	497,988	20,481	-	-
Total	<u>\$ 11,198,273</u>	<u>\$ 7,367,867</u>	<u>\$ 2,371,287</u>	<u>\$ 448,019</u>

At June 30, 2016 Camden County had a legal debt margin of \$13,569,559.

Notes to the Financial Statements

c. Long-Term Obligation Activity

The following is a summary of changes in the County's long-term obligations for the fiscal year ended June 30, 2016:

	Balance 6/30/2015	Increases	Decreases	Balance 6/30/2016	Current Portion
Governmental Activities:					
Installment Purchases	\$ 11,744,964	\$ -	\$ (546,691)	\$ 11,198,273	\$ 553,990
OPEB	363,454	68,407	-	431,861	-
Net pension liability (LRS)	-	196,545	-	196,545	-
Compensated absences	208,785	79,662	(90,709)	197,738	79,662
Total governmental activities	\$ 12,317,203	\$ 344,614	\$ (637,400)	\$ 12,024,417	\$ 633,652

	Balance 6/30/2015	Additions	Retirements	Balance 6/30/2016	Current Portion
Business Type Activities:					
General obligation debt	\$ 2,594,711	\$ -	\$ (223,424)	\$ 2,371,287	\$ 225,324
OPEB	69,229	14,071	-	83,300	-
Net pension liability (LRS)	-	21,838	-	21,838	-
Compensated Absences	27,006	11,389	(3,963)	34,432	11,389
Total business type activities	\$ 2,690,946	\$ 47,298	\$ (227,387)	\$ 2,510,857	\$ 236,713

Compensated absences for governmental activities typically have been liquidated in the general fund and are accounted for on a LIFO basis, assuming that employees are taking leave time as it is earned.

Debt Related to Capital Activities - Of the total Governmental Activities debt listed only \$1,176,189 relates to assets the County holds title.

Inter-fund Balances and Activity

Transfers From/To Other Funds at June 30, 2016 consists of the following:

From the General fund to:

Water and Sewer Fund (Expenditures)	\$ 1,157,000
Community Park Trust Fund (Expenditures)	91,629
Special Capital Fund (Expenditures)	325,000

From School Capital Fund to:

General Fund (school debt)	(715,949)
----------------------------	-----------

Totals	\$ 857,680
---------------	-------------------

Interfund Balances and Activity

The composition of interfund balance activity as of June 30, 2016 is as follows:

From the Courthouse and Shiloh FD Fund to the General Fund.

Total	\$ 119,500
-------	-------------------

All of the above were for operating expenditures.

C. Fund Balance

The following schedule provides management and citizens with information on the portion of General fund balance that is available for appropriation:

Total fund balance - General Fund	\$ 7,153,194
Less:	
Stabilization by State Statute	589,309
Remaining Fund Balance	\$ 6,563,885

III. Joint Ventures

Developmental Disabilities & Substance abuse Services

The County participates in a joint venture to provide mental health services. East Carolina Behavioral Health (ECBH) coordinates these services through third party providers. The County is one of nineteen county governments participating as a joint venture. Camden County appointed one board member (commissioner) to the ECBH's finance committee. The venture was established as a joint venture among the participating counties to coordinate funding from federal and State agencies and also to realize economies of scale in the providing of mental health services. In accordance with the intergovernmental agreement between the participating governments and ECBH, the County appropriated \$20,000 to the ECBH to supplement its activities. None of the participating governments have any equity interest in the ECBH, so no equity interest has been reflected in the financial statements at June 30, 2016. Complete financial statements can be obtained from the ECBH's office at 112 Health Drive, Greenville, North Carolina 27834-7704.

Central Communications/Emergency Management System

The Emergency Management System was established as a joint venture between Camden County, Pasquotank County, and the City of Elizabeth City to coordinate grant funds and realize economies of scale. Each entity appoints one member to the governing board. In accordance with the intergovernmental agreement between the participating governments, the County appropriated \$251,213 to the System to supplement its activities. None of the participating governments have any equity interest in the System, so no equity interest has been reflected in the financial statements at June 30, 2016. Complete financial statements for the System can be obtained from the System's office at 103 S. Road Street, Elizabeth City, North Carolina 27909.

Albemarle District Jail

The operation of the Jail is shared with two other counties in the surrounding area. Each county's contributions are based on a per capita assessment based on the most recent census figures available, and each county appoints one or more members to the Board. In accordance with the intergovernmental agreement between the participating governments, the County appropriated \$405,920 to the Jail to supplement its activities. None of the participating governments have any equity interest in the Jail, so no equity interest has been reflected in the financial statements at June 30, 2016. Complete financial statements for the Jail can be obtained from the Jail's office at 320 S. Hughes Blvd., Elizabeth City, North Carolina 27907.

Albemarle Commission

The County is a member of the Albemarle Commission, which is a voluntary association of county governments. The Commission was established as a joint venture among the participating counties to coordinate funding from federal and State agencies. – the makeup is 1 elected official from each of the 10 counties with a term that does not expire unless the individual is no longer an elected official or another appointment is made by the county. Four at-large members that rotate off the AC Board every 2 years. Currently, the members until the end of the month, are from Currituck, Dare, Gates and Hyde. Starting in January, the members will be from Pasquotank, Perquimans, Tyrrell and Washington until December 31st 2018. On January 1, 2019 the members will be from Camden Chowan Currituck and Dare. The County paid membership fees of \$6,613 to the Commission during the fiscal year ended June 30, 2016.

Regional Confinement Facility

The County is a member of the Regional Jail Facility, which is an agreement of three county governments to provide financing, construction and operation of a regional jail. The Facility was established as a joint venture among the participating counties to coordinate funding from local, federal, and State agencies. The County contributed \$185,899 to the Facility during the fiscal year ended June 30, 2016.

Albemarle Regional Health Services (ARHS)

Albemarle Regional Health Services is a voluntary association of seven county governments. ARHS was established as a joint venture among the participating counties to coordinate funding from federal and State agencies and to realize economies of scale in providing health care services. The County contributed \$118,166 to ARHS during the year ended June 30, 2016. None of the participating governments have any equity interest in ARHS, so no equity interest has been reflected in the financial statements at June 30, 2016. Complete financial statements can be obtained at ARHS's office on 711 Roanoke Avenue, Elizabeth City, North Carolina 27909.

IV. Benefit Payments Issued by the State

The amounts listed below were paid directly to individual recipients by the State from federal and State moneys. County personnel are involved with certain functions, primarily eligibility determinations, which cause benefit payments to be issued by the State. These amounts disclose this additional aid to the County recipients that do not appear in the basic financial statements because they are not revenues and expenditures of the County.

	Federal	State
Adoption Assistance	\$ 19,286	\$ 4,936
Low Income Energy Assistance	23,200	-
Medicaid	4,245,225	2,347,451
NC Health Choice	171,026	8,019
Foster Care	4,451	7,739
WIC	15,286	-

V. Summary Disclosure of Significant Commitments and Contingencies

Federal and State Assisted Programs

The County has received proceeds from federal and State grants. Periodic audits of these grants are required and certain costs may be questioned as not being appropriate expenditures under the grant agreements. Such audits could result in the refund of grant moneys to the grantor agencies. Management believes that any required refunds will be immaterial. no provision has been made in the accompanying financial statements for the refund of grant moneys.

VI. Significant Effects of Subsequent Events

There are no subsequent events that would have a material affect on the financial statements. Subsequent events have been analyzed through the date that the financial statements were available to be issued.

REQUIRED
SUPPLEMENTAL FINANCIAL DATA

This section contains additional information required by generally accepted accounting principles.

Schedule of Funding Progress for Other Postemployment Benefits

Schedule of Employer Contributions for Other Postemployment Benefits

Schedule of Proportionate Share of the Net Pension Asset - Local Government Employees' Retirement System

Schedule of Contributions - Local Government Employees' Retirement System

Schedule of the Proportionate Share of the Net Pension Asset - Register of Deeds

Schedule of Contributions - Register of Deeds

**Camden County, North Carolina
Other Post Employment Benefits
Required Supplementary Information
Schedule of Funding Progress**

Actuarial Valuation Date	Actuarial Value of Assets (a)	Actuarial Liability (AAL) - Projected Unit Credit (b)	Unfunded AAL (UAAL) (b - a)	Funded Ratio (a/b)	Covered Payroll (c)	UAAL as a % of Covered Payroll ((b - a)/c)
12/31/2011	-	\$ 565,640	\$ 565,640	0.0%	\$ 2,375,630	23.80%
12/31/2012	-	\$ 636,078	\$ 636,078	0.0%	\$ 2,788,528	22.81%
12/31/2013	-	\$ 636,078	\$ 636,078	0.0%	\$ 2,788,528	22.81%
12/31/2014	-	\$ 663,838	\$ 663,838	0.0%	\$ 2,067,678	32.11%
12/31/2015	-	\$ 663,838	\$ 663,838	0.0%	\$ 2,067,678	32.11%

Attachment: 2015-2016 Camden County Audit (1494 : FY 15-16 Audit by Greg Allison of Thompson, Price, Scott, Adams, & Co., PA)

Camden County, North Carolina
Other Post Employment Benefits
Required Supplementary Information
Schedule of Employer Contributions

<u>Year Ended June 30,</u>	<u>Annual Required Contribution</u>	<u>Percentage Contributed</u>
2013	70,438	0.00%
2014	70,190	0.00%
2015	87,493	0.00%
2016	87,493	0.00%

Notes to the Required Schedules:

The information presented in the required supplementary schedules was determined as part of the actuarial valuations at the dates indicated. Additional information as of the latest actuarial valuation follows.

Valuation Date	December 31, 2015
Actuarial Cost Method	Projected Unit Credit
Amortization Method	Level Percent of Pay Open
Remaining Amortization Period	30 Years
Asset Valuation Method	Market Value
Actuarial Assumptions:	
Investment Rate of Return	4.00%
Medical Cost Trend	7.5% - 5.00%
Includes Inflation at	3.00%

Attachment: 2015-2016 Camden County Audit (1494 : FY 15-16 Audit by Greg Allison of Thompson, Price, Scott, Adams, & Co., PA)

Camden County, North Carolina
Camden County's Proportionate Share of Net Pension Liability (Asset)
Required Supplementary Information
Last Three Fiscal Years

Local Government Employees' Retirement System

	2016	2015	2014
County's proportion of the net pension liability (asset) (%)	0.0487%	0.0489%	0.0452%
County's proportion of the net pension liability (asset) (\$)	\$ 218,383	\$ (288,268)	\$ 544,834
County's covered-employee payroll	\$ 2,915,721	\$ 2,883,647	\$ 2,788,528
County's proportionate share of the net pension liability (asset) as a percentage of its covered-employee payroll	7.49%	(10.00%)	19.54%
Plan fiduciary net position as a percentage of the total pension liability**	98.09%	102.64%	94.35%

* The amounts presented for each fiscal year were determined as of the prior fiscal year ending June 30.

** This will be the same percentage for all participant employers in the LGERS plan.

Attachment: 2015-2016 Camden County Audit (1494 : FY 15-16 Audit by Greg Allison of Thompson, Price, Scott, Adams, & Co., PA)

**Camden County, North Carolina
Camden County's Contributions
Required Supplementary Information
Last Three Fiscal Years**

Local Government Employees' Retirement System

	<u>2016</u>	<u>2015</u>	<u>2014</u>
Contractually required contribution	\$ 208,510	\$ 220,612	\$ 219,096
Contributions in relation to the contractually required contribution	208,510	220,612	219,096
Contribution deficiency (excess)	<u>\$ -</u>	<u>\$ -</u>	<u>\$ -</u>
County's covered-employee payroll	\$ 3,034,188	\$ 2,915,721	\$ 2,883,647
Contributions as a percentage of covered- employee payroll	6.87%	7.57%	7.60%

Camden County, North Carolina
Camden County's Proportionate Share of Net Pension Liability (Asset)
Required Supplementary Information
Last Three Fiscal Years

Registers of Deeds' Supplemental Pension Fund

	2016	2015	2014
County's proportion of the net pension liability (asset) (%)	0.0952%	0.1010%	0.1130%
County's proportion of the net pension liability (asset) (\$)	\$ (22,066)	\$ (22,909)	\$ (24,145)
County's covered-employee payroll	\$ 54,047	\$ 70,695	\$ 50,049
County's proportionate share of the net pension liability (asset) as a percentage of its covered-employee payroll	(40.83%)	(32.41%)	(44.67%)
Plan fiduciary net position as a percentage of the total pension liability**	197.29%	193.88%	190.50%

* The amounts presented for each fiscal year were determined as of the prior fiscal year ending June 30.

** This will be the same percentage for all participant employers in the ROD plan.

Attachment: 2015-2016 Camden County Audit (1494 : FY 15-16 Audit by Greg Allison of Thompson, Price, Scott, Adams, & Co., PA)

**Camden County, North Carolina
Camden County's Contributions
Required Supplementary Information
Last Three Fiscal Years**

Registers of Deeds' Supplemental Pension Fund

	<u>2016</u>	<u>2015</u>	<u>2014</u>
Contractually required contribution	\$ 3,024	\$ 3,631	\$ 3,821
Contributions in relation to the contractually required contribution	3,024	3,631	3,821
Contribution deficiency (excess)	<u>\$ -</u>	<u>\$ -</u>	<u>\$ -</u>
County's covered-employee payroll	\$ 51,364	\$ 54,047	\$ 70,695
Contributions as a percentage of covered-employee payroll	5.89%	6.72%	5.40%

GENERAL FUND

The General Fund accounts for resources traditionally associated with government that are not required legally or by sound financial management to be accounted for in other funds.

**Camden County, North Carolina
General Fund
Schedule of Revenues, Expenditures, and
Changes in Fund Balances - Budget and Actual
For the Fiscal Year Ended June 30, 2016**

	Final Budget	Actual	Variance Positive (Negative)
Revenues:			
Ad Valorem Taxes:			
Taxes	\$	\$ 7,255,895	\$
Penalties and Interest		70,036	
Total	<u>7,226,231</u>	<u>7,325,931</u>	<u>99,700</u>
Other Taxes and Licenses:			
Local option sales tax		1,047,860	
Utilities sales tax		652,335	
Telecommunications tax		93,728	
Scrap tire disposal tax		20,234	
Video franchise fee		72,314	
White goods tax		3,487	
Medicaid hold harmless		599,223	
Total	<u>2,486,000</u>	<u>2,489,181</u>	<u>3,181</u>
Unrestricted Intergovernmental revenues:			
Beer and wine tax		44,896	
Payments in lieu of taxes		720	
ABC profit distribution		36,014	
Total	<u>81,216</u>	<u>81,630</u>	<u>414</u>
Restricted Intergovernmental:			
State and Federal Grants		1,092,204	
ABC profits for law enforcement		4,361	
Solid waste disposal tax		8,153	
Court facilities fees		24,362	
Total	<u>1,188,686</u>	<u>1,129,080</u>	<u>(59,606)</u>
Permits and Fees:			
Pet licenses		285	
Gun permits		20,022	
Fines and forfeitures		62,354	
Register of Deeds		144,448	
Business registration fee		335	
Other fees		30,240	
Building permits and inspections, including land use fees		414,873	
Total	<u>699,726</u>	<u>672,557</u>	<u>(27,169)</u>

**Camden County, North Carolina
General Fund
Schedule of Revenues, Expenditures, and
Changes in Fund Balances - Budget and Actual
For the Fiscal Year Ended June 30, 2016**

	Final Budget	Actual	Variance Positive (Negative)
Sales and Services:			
Rent and Concessions		42,031	
Jail fees		3,211	
Officer fees		50,029	
Total	89,850	95,271	5,421
Investment Earnings: Interest	47,178	44,386	(2,792)
Miscellaneous:			
Sale of fixed assets		16,541	
Insurance proceeds		11,515	
Sale of recyclables		7,699	
Other		11,606	
Total	28,051	47,361	19,310
TOTAL REVENUES	11,846,938	11,885,397	38,459
Expenditures:			
General Government:			
Governing body		73,801	
Administration		384,786	
Finance		192,317	
Tax administration		401,901	
Personnel		65,254	
Legal		39,072	
Register of deeds		204,811	
Elections		117,200	
Public buildings		398,718	
Court facilities		40,730	
Total general government	2,144,775	1,918,590	226,185

**Camden County, North Carolina
General Fund
Schedule of Revenues, Expenditures, and
Changes in Fund Balances - Budget and Actual
For the Fiscal Year Ended June 30, 2016**

	Final Budget	Actual	Variance Positive (Negative)
Public Safety:			
Sheriff		1,667,408	
Jail		185,899	
Regional jail		405,920	
Juvenile justice and delinquency program		66,596	
School resource officer		69,691	
Inspections		117,683	
Contribution to fire districts		419,995	
Emergency management		498,798	
Central communications		251,213	
Total	<u>3,703,945</u>	<u>3,683,203</u>	<u>20,742</u>
Economic and physical development:			
Economic development		145,980	
Agricultural extension		75,145	
Planning		277,290	
Albemarle commission		6,613	
Resource conservation and development		750	
Soil/water conservation		62,256	
Total	<u>708,712</u>	<u>568,034</u>	<u>140,678</u>
Human services:			
Health:			
Albemarle hopeline		2,000	
Camden food pantry		2,000	
Regional health		118,166	
Other health programs		1,643	
Total human services	<u>213,222</u>	<u>123,809</u>	<u>89,413</u>
Transportation: Traffic	<u>3,560</u>	<u>1,701</u>	<u>1,859</u>

**Camden County, North Carolina
General Fund
Schedule of Revenues, Expenditures, and
Changes in Fund Balances - Budget and Actual
For the Fiscal Year Ended June 30, 2016**

	Final Budget	Actual	Variance Positive (Negative)
Social services:			
Administration		944,796	
Day care		133,187	
Medical travel		16,481	
County provided assistance		53,179	
Adoptions		6,679	
Aid to the blind program		852	
Foster care		21,589	
Crisis intervention		22,919	
Work first program		37,166	
LIEAP expenses		23,700	
Other assistance		1,907	
Total social services	<u>1,350,433</u>	<u>1,262,455</u>	<u>87,978</u>
Total Human Services	<u>1,567,215</u>	<u>1,387,965</u>	<u>179,250</u>
Cultural and Recreational:			
Recreation		254,591	
Library		177,008	
Museum		1,036	
College of the Albemarle		40,000	
Senior citizens services		121,443	
Total Cultural and Recreational	<u>628,034</u>	<u>594,078</u>	<u>33,956</u>
Environmental protection:			
Public works administration		121,321	
Forestry program		51,889	
Sanitation		622,736	
Total environmental protection	<u>816,817</u>	<u>795,946</u>	<u>20,871</u>
Education:			
Public Schools:			
Current Expense		2,072,942	
Capital Outlay		298,783	
Total Education	<u>2,371,725</u>	<u>2,371,725</u>	<u>-</u>
Debt Service:			
Principal Retirement		469,649	
Interest and Fees		394,686	
Total Debt Service	<u>864,335</u>	<u>864,335</u>	<u>-</u>
TOTAL EXPENDITURES	<u>12,805,558</u>	<u>12,183,876</u>	<u>621,682</u>
Revenues over Expenditures	<u>(958,620)</u>	<u>(298,479)</u>	<u>660,141</u>

Attachment: 2015-2016 Camden County Audit (1494 : FY 15-16 Audit by Greg Allison of Thompson, Price, Scott, Adams, & Co., PA)

**Camden County, North Carolina
General Fund
Schedule of Revenues, Expenditures, and
Changes in Fund Balances - Budget and Actual
For the Fiscal Year Ended June 30, 2016**

	<u>Final Budget</u>	<u>Actual</u>	<u>Variance Positive (Negative)</u>
Other financing sources (uses):			
Fund Balance Appropriated		-	
Transfers (to)/from Other Funds:			
Special revenue - school capital fund		715,949	
Water and sewer district		<u>(1,573,629)</u>	
Total Other Financing Sources (Uses)	<u>958,620</u>	<u>(857,680)</u>	<u>(1,816,300)</u>
 Net change in fund balance	 <u>\$ -</u>	 <u>(1,156,159)</u>	 <u>\$ (1,156,159)</u>
 Fund balances:			
Beginning of year, July 1		<u>8,309,353</u>	
End of year, June 30		<u>\$ 7,153,194</u>	

Attachment: 2015-2016 Camden County Audit (1494 : FY 15-16 Audit by Greg Allison of Thompson, Price, Scott, Adams, & Co., PA)

OTHER MAJOR GOVERNMENTAL FUNDS

Major Governmental Funds - Fire Districts Fund- Courthouse & Shiloh
Major Governmental Funds - Special Capital Fund

Camden County, North Carolina
Fire District Funds - Courthouse and Shiloh
Schedule of Revenues, Expenditures, and
Changes in Fund Balances - Budget and Actual
For the Fiscal Year Ended June 30, 2016

	2016		Variance Favorable (Unfavorable)
	Final Budget	Actual	
Revenues:			
Ad valorem taxes	\$	\$ 66,572	\$
Restricted intergovernmental		2,000	
Other taxes		261,765	
Investment earnings		1,361	
Other fees		9,373	
Miscellaneous		50	
Total Revenues	<u>565,816</u>	<u>341,121</u>	<u>(224,695)</u>
Expenditures:			
Public safety:			
Salaries and benefits		4,415	
Operating expenses		180,927	
Capital outlay		502,706	
Debt service: Principal and Interest		-	
Total Expenditures	<u>829,775</u>	<u>688,048</u>	<u>141,727</u>
Revenues Over (Under) Expenditures	<u>(263,959)</u>	<u>(346,927)</u>	<u>(82,968)</u>
Other Financing Sources (Uses):			
Proceeds from Installment Loan	-	-	-
Transfer to General Fund	-	-	-
Total Other Financing Sources (Uses)	<u>-</u>	<u>-</u>	<u>-</u>
Revenues and Other Financing Sources Over (Under) Uses	<u>(263,959)</u>	<u>(346,927)</u>	<u>(82,968)</u>
Fund Balance Appropriated	<u>263,959</u>	<u>-</u>	<u>(263,959)</u>
Net change in fund balance	\$ <u>-</u>	(346,927)	\$ <u>(346,927)</u>
Fund Balance:			
Beginning of Year, July 1		<u>469,464</u>	
End of Year, June 30		\$ <u>122,537</u>	

Camden County, North Carolina
Special Capital Fund
Schedule of Revenues, Expenditures, and
Changes in Fund Balances - Budget and Actual
For the Fiscal Year Ended June 30, 2016

	2016		Variance Favorable (Unfavorable)
	Budget	Actual	
Revenues			
Other taxes	\$	\$ 428,919	\$
Land sale		-	
Investment earnings		14,957	
Total Revenue	<u>320,000</u>	<u>443,876</u>	<u>123,876</u>
Expenditures			
Operating expenses		970,846	
Capital outlay		-	
Total Expenditures	<u>1,722,083</u>	<u>970,846</u>	<u>751,237</u>
Revenues Over (Under) Expenditures	<u>(1,402,083)</u>	<u>(526,970)</u>	<u>875,113</u>
Other Financing Sources (Uses):			
Transfers from other funds	325,000	325,000	-
Proceeds from Lease Purchase		-	-
Total Other Financing Sources (Uses)	<u>325,000</u>	<u>325,000</u>	<u>-</u>
Revenues and Other Financing Sources Over (Under) Expenditures and Other Uses	(1,077,083)	(201,970)	875,113
Fund Balance Appropriated	<u>1,077,083</u>	<u>-</u>	<u>(1,077,083)</u>
Net change in fund balance	\$ <u>-</u>	(201,970)	\$ <u>(201,970)</u>
Fund Balance:			
Beginning of Year, July 1		<u>2,782,966</u>	
End of Year, June 30		<u>\$ 2,580,996</u>	

Camden County, North Carolina
 Nonmajor Governmental Funds
 Combining Balance Sheet
 June 30, 2016

	Special Revenue Funds										Capital Project Funds			
	Automation Enhancement and Preservation Fund	Watershed Fund	Dismal Swamp Visitor Center	School Cap Fund	South Mills VFD	Joyce Creek Drainage Fund	Community Park Trust	Eco Dev Fund	School Fund	Revaluation Fund	Total Nonmajor Special Revenue Funds	Scattered Housing Grant	Total Nonmajor Capital Project Funds	Total Nonmajor Governmental Funds
Assets:														
Cash and investments	\$ 11,363	\$ 88,668	\$ 89,978	\$ -	\$ 377,640	\$ 233,875	\$ 80,642	\$ 175,313	\$ 13,812	\$ 359,890	\$ 1,431,181	\$ 6,530	\$ 6,530	\$ 1,437,711
Restricted Cash	-	-	-	249,772	-	-	-	-	-	-	249,772	-	-	249,772
Accounts receivable	-	-	371	100,641	4,369	-	178,014	-	-	-	283,395	-	-	283,395
Taxes receivable (net)	-	-	-	-	746	831	-	-	-	-	1,577	-	-	1,577
Total Assets	\$ 11,363	\$ 88,668	\$ 90,349	\$ 350,413	\$ 382,755	\$ 234,706	\$ 258,656	\$ 175,313	\$ 13,812	\$ 359,890	\$ 1,965,925	\$ 6,530	\$ 6,530	\$ 1,972,455
Liabilities and Fund Balances:														
Current liabilities:														
Accounts payable	\$ -	\$ -	\$ 8,158	\$ 14,375	\$ 580	\$ -	\$ 1,189	\$ -	\$ -	\$ -	\$ 24,302	\$ -	\$ -	\$ 24,302
Due from other funds	-	-	-	-	-	-	-	-	-	-	-	-	-	-
Total liabilities	-	-	8,158	14,375	580	-	1,189	-	-	-	24,302	-	-	24,302
Deferred Inflows of Resources														
Property taxes receivable	-	-	-	-	746	831	-	-	-	-	1,577	-	-	1,577
Total deferred inflows of resources	-	-	-	-	746	831	-	-	-	-	1,577	-	-	1,577
Fund Balances:														
Restricted	-	-	371	100,641	4,369	-	178,014	-	-	-	283,395	-	-	283,395
Stabilization by State Statute	-	-	-	-	-	-	-	-	-	-	11,363	-	-	11,363
Register of Deeds	11,363	-	-	-	-	-	-	-	-	-	-	-	-	-
Fire Protection	-	-	-	-	377,060	-	-	-	-	-	377,060	-	-	377,060
Committed	-	-	-	-	-	-	-	-	-	359,890	-	-	-	359,890
Tax Revaluation	-	-	-	-	-	-	-	-	-	-	359,890	-	-	359,890
School capital	-	-	-	235,397	-	-	-	-	13,812	-	249,209	-	-	249,209
Economic development	-	88,668	81,820	-	-	233,875	79,453	175,313	-	-	659,129	6,530	6,530	665,659
Total fund balances	11,363	88,668	82,191	336,038	381,429	233,875	257,467	175,313	13,812	359,890	1,940,046	6,530	6,530	1,946,576
Total liabilities, deferred inflows of resources, and fund balances	\$ 11,363	\$ 88,668	\$ 90,349	\$ 350,413	\$ 382,755	\$ 234,706	\$ 258,656	\$ 175,313	\$ 13,812	\$ 359,890	\$ 1,965,925	\$ 6,530	\$ 6,530	\$ 1,972,455

**Camden County, North Carolina
Nonmajor Governmental Funds
Combining Statement of Revenues, Expenditures, and
Changes in Fund Balances
For the Fiscal Year Ended June 30, 2016**

	Auto Enhancement and Preserva- tion Fund	Watershed Fund	Dismal Swamp Visitor Center	School Cap Fund	South Mills VFD	Joyce Creek Drainage Fund	Community Park Trust	Eco Dev Fund	School Fund	Revaluation Fund	Total Nonmajor Special Revenue Funds	Scattered Housing Grant	Total Nonmajor Capital Project Funds	Total Nonmajor Governmental Funds
Revenues:														
Ad Valorem Taxes	\$ -	\$ -	\$ -	\$ -	\$ 40,129	\$ 20,923	\$ -	\$ -	\$ -	\$ -	\$ 61,052	\$ -	\$ -	\$ 61,052
Other taxes	-	-	-	565,239	158,230	-	-	-	6,680	-	730,149	-	-	730,149
Local contributions	-	-	-	448,783	-	-	-	40,000	-	-	488,783	-	-	488,783
Donations	-	-	-	-	-	-	-	-	-	-	-	-	-	-
Investment earnings	87	591	-	2,359	1,994	1,232	687	805	62	2,085	9,902	-	-	9,902
Sales	-	-	30,722	-	-	-	-	-	-	-	30,722	-	-	30,722
Miscellaneous	-	-	508	351	-	-	-	-	-	-	859	-	-	859
Federal and State grants	-	-	142,857	-	30,000	-	227,492	-	-	-	400,349	-	-	400,349
Fees	5,497	97,854	-	-	-	-	-	-	-	-	103,351	-	-	103,351
Total revenues	5,584	98,445	174,087	1,016,732	230,353	22,155	228,179	40,805	6,742	2,085	1,825,167	-	-	1,825,167
Expenditures:														
General government	9,000	-	174,499	-	-	-	-	-	-	36,795	220,294	-	-	220,294
Public safety	-	-	-	-	132,620	-	-	-	-	-	132,620	-	-	132,620
Environmental protection	-	-	-	-	-	9,685	-	-	-	-	9,685	-	-	9,685
Economic and physical development	-	98,461	-	-	-	-	322,097	19,000	-	-	439,558	-	-	439,558
Cultural and recreation	-	-	-	-	-	-	-	-	-	-	-	-	-	-
Education	-	-	-	298,748	-	-	-	-	-	-	298,748	-	-	298,748
Debt service:														
Principal retirement	-	-	-	-	77,042	-	-	-	-	-	77,042	-	-	77,042
Interest and fees	-	-	-	-	27,006	-	-	-	-	-	27,006	-	-	27,006
Total Expenditures	9,000	98,461	174,499	298,748	236,668	9,685	322,097	19,000	-	36,795	1,204,953	-	-	1,204,953
Revenues Over (Under) Expenditures	(3,416)	(16)	(412)	717,984	(6,315)	12,470	(93,918)	21,805	6,742	(34,710)	620,214	-	-	620,214
Other Financing Sources (Uses):														
Proceeds of long-term debt	-	-	-	-	-	-	-	-	-	-	-	-	-	-
Transfers from (to) other sources	-	-	-	-	-	-	91,629	-	-	-	91,629	-	-	91,629
Transfers from (to) CU	-	-	-	-	-	-	-	-	-	-	-	-	-	-
Transfers from (to) other sources	-	-	-	(715,949)	-	-	91,629	-	-	-	(624,320)	-	-	(624,320)
Total other financing sources (uses)	-	-	-	(715,949)	-	-	183,258	-	-	-	(532,691)	-	-	(532,691)
Net change in Fund Balance	(3,416)	(16)	(412)	2,035	(6,315)	12,470	89,340	21,805	6,742	(34,710)	87,523	-	-	87,523
Fund balances:														
Beginning of Year, July 1	14,779	88,684	82,603	334,003	387,744	221,405	259,756	153,508	7,070	394,600	1,944,152	6,530	6,530	1,950,682
End of year, June 30	\$ 11,363	\$ 88,668	\$ 82,191	\$ 336,038	\$ 381,429	\$ 233,875	\$ 349,096	\$ 175,313	\$ 13,812	\$ 359,890	\$ 2,031,675	\$ 6,530	\$ 6,530	\$ 2,038,205

Attachment: 2015-2016 Camden County Audit (1494 : FY 15-16 Audit by Greg Allison of Thompson, Price, Scott, Adams, & Co., PA)

SPECIAL REVENUE FUNDS

Special Revenue Funds are used to account for specific revenues that are legally restricted to expenditure for particular purposes.

Camden County, North Carolina
Automation Enhancement and Preservation Fund
Schedule of Revenues, Expenditures, and
Changes in Fund Balances - Budget and Actual
For the Fiscal Year Ended June 30, 2016

	2016		Variance Favorable (Unfavorable)
	Final Budget	Actual	
Revenues			
Fees	\$	\$ 5,497	\$
Investment Earnings		87	
Other income		-	
Total revenues	<u>4,100</u>	<u>5,584</u>	<u>1,484</u>
Expenditures:			
Operating expenses		9,000	
Total Expenditures	<u>9,100</u>	<u>9,000</u>	<u>100</u>
Revenues Over (Under) Expenditures	<u>(5,000)</u>	<u>(3,416)</u>	<u>1,584</u>
Other Financing Sources (Uses):			
Transfers from Other Funds		-	
Transfers to Other Funds		-	
Total Other Financing Sources (Uses)	<u>-</u>	<u>-</u>	<u>-</u>
Revenues and Other Financing Sources Over (Under) Uses	(5,000)	(3,416)	1,584
Fund Balance Appropriated	<u>5,000</u>	<u>-</u>	<u>(5,000)</u>
Net change in fund balance	\$ <u>-</u>	(3,416)	\$ <u>(3,416)</u>
Fund Balance:			
Beginning of Year, July 1		<u>14,779</u>	
End of Year, June 30		\$ <u><u>11,363</u></u>	

Camden County, North Carolina
Watershed Fund
Schedule of Revenues, Expenditures, and
Changes in Fund Balances - Budget and Actual
For the Fiscal Year Ended June 30, 2016

	2016		Variance Favorable (Unfavorable)
	Final Budget	Actual	
Revenues			
Fees	\$	\$ 97,854	\$
Investment earnings		591	
Total revenues	<u>116,325</u>	<u>98,445</u>	<u>17,880</u>
Expenditures:			
Operating expenses		98,461	
Total Expenditures	<u>162,631</u>	<u>98,461</u>	<u>64,170</u>
Revenues Over (Under) Expenditures	<u>(46,306)</u>	<u>(16)</u>	<u>46,290</u>
Net change in fund balance	(46,306)	(16)	46,290
Fund Balance Appropriated	<u>46,306</u>	<u>-</u>	<u>(46,306)</u>
Net change in fund balance	\$ <u><u>-</u></u>	(16)	\$ <u><u>(16)</u></u>
Fund Balance:			
Beginning of Year, July 1		<u>88,684</u>	
End of Year, June 30		\$ <u><u>88,668</u></u>	

**Camden County, North Carolina
Dismal Swamp Visitor Center
Schedule of Revenues, Expenditures, and
Changes in Fund Balances - Budget and Actual
For the Fiscal Year Ended June 30, 2016**

	2016		Variance Favorable (Unfavorable)
	Final Budget	Actual	
Revenues			
Restricted Intergovernmental	\$	\$ 142,857	\$
Sales		30,722	
Miscellaneous		508	
Total Revenue	<u>176,800</u>	<u>174,087</u>	<u>(2,713)</u>
Expenditures			
Salaries and benefits		141,496	
Operating expenses		33,003	
Total Expenditures	<u>181,900</u>	<u>174,499</u>	<u>7,401</u>
Revenues Over (Under) Expenditures	<u>(5,100)</u>	<u>(412)</u>	<u>4,688</u>
Other Financing Sources (Uses):			
Transfers from other funds	-	-	-
Proceeds from Lease Purchase	-	-	-
Total Other Financing Sources (Uses)	<u>-</u>	<u>-</u>	<u>-</u>
Revenues and Other Financing Sources Over (Under) Expenditures and Other Uses	(5,100)	(412)	4,688
Fund Balance Appropriated	<u>5,100</u>	<u>-</u>	<u>(5,100)</u>
Net change in fund balance	\$ <u>-</u>	(412)	\$ <u>(412)</u>
Fund Balance:			
Beginning of Year, July 1		<u>82,603</u>	
End of Year, June 30		\$ <u><u>82,191</u></u>	

Camden County, North Carolina
School Capital Fund
Schedule of Revenues, Expenditures, and
Changes in Fund Balances - Budget and Actual
For the Fiscal Year Ended June 30, 2016

	2016		Variance Favorable (Unfavorable)
	Budget	Actual	
Revenues:			
Other taxes	\$	\$ 565,239	\$
Local contributions		448,783	
Miscellaneous		351	
Investment earnings		2,359	
Total Revenues	<u>1,285,255</u>	<u>1,016,732</u>	<u>(268,523)</u>
Expenditures:			
Education:			
Operating expenses		298,748	
Debt service: Principal		-	
Debt service: Interest		-	
Total Expenditures	<u>541,217</u>	<u>298,748</u>	<u>242,469</u>
Revenues Over (Under) Expenditures	<u>744,038</u>	<u>717,984</u>	<u>(26,054)</u>
Other Financing Sources (Uses):			
Transfer from other funds	-	-	-
Transfer to other funds	<u>(744,038)</u>	<u>(715,949)</u>	<u>28,089</u>
Total Other Financing Sources (Uses)	<u>(744,038)</u>	<u>(715,949)</u>	<u>28,089</u>
Revenues and Other Financing Sources Over (Under) Uses	-	2,035	2,035
Fund Balance Appropriated	<u>-</u>	<u>-</u>	<u>-</u>
Net change in fund balance	\$ <u>-</u>	2,035	\$ <u>2,035</u>
Fund Balance:			
Beginning of Year, July 1		<u>334,003</u>	
End of Year, June 30		<u>\$ 336,038</u>	

**Camden County, North Carolina
Fire District Fund - South Mills
Schedule of Revenues, Expenditures, and
Changes in Fund Balances - Budget and Actual
For the Fiscal Year Ended June 30, 2016**

	2016		Variance Favorable (Unfavorable)
	Final Budget	Actual	
Revenues:			
Ad valorem taxes	\$	\$ 40,129	\$
Other taxes		158,230	
Investment earnings		1,994	
Other grants		30,000	
Other fees		-	
Total Revenues		<u>256,522</u>	<u>(26,169)</u>
Expenditures:			
Public safety:			
Salaries and benefits		6,460	
Operating expenses		126,161	
Capital outlay		-	
Debt service: Principal and Interest		104,047	
Total Expenditures		<u>256,522</u>	<u>19,854</u>
Revenues Over (Under) Expenditures	-	<u>(6,315)</u>	<u>(6,315)</u>
Other Financing Sources (Uses):			
Proceeds from Installment Loan	-	-	-
Transfer to General Fund	-	-	-
Total Other Financing Sources (Uses)	<u>-</u>	<u>-</u>	<u>-</u>
Revenues and Other Financing Sources Over (Under) Uses	-	<u>(6,315)</u>	<u>(6,315)</u>
Fund Balance Appropriated	<u>-</u>	<u>-</u>	<u>-</u>
Net change in fund balance	<u>\$ -</u>	<u>(6,315)</u>	<u>\$ (6,315)</u>
Fund Balance:			
Beginning of Year, July 1		<u>387,744</u>	
End of Year, June 30		<u>\$ 381,429</u>	

Attachment: 2015-2016 Camden County Audit (1494 : FY 15-16 Audit by Greg Allison of Thompson, Price, Scott, Adams, & Co., PA)

Camden County, North Carolina
Drainage Fund - Joyce Creek
Schedule of Revenues, Expenditures, and
Changes in Fund Balances - Budget and Actual
For the Fiscal Year Ended June 30, 2016

	2016		Variance Favorable (Unfavorable)
	Final Budget	Actual	
Revenues:			
Ad valorem taxes	\$	\$ 20,923	\$
Investment earnings		1,232	
Total Revenues	<u>50,712</u>	<u>22,155</u>	<u>(28,557)</u>
Expenditures:			
Environmental Protection:			
Operating expenses		9,685	
Capital outlay		-	
Total Expenditures	<u>50,712</u>	<u>9,685</u>	<u>41,027</u>
Revenues Over (Under) Expenditures	<u>-</u>	<u>12,470</u>	<u>12,470</u>
Other Financing Sources (Uses):			
Proceeds from Installment Loan	-	-	-
Transfer to General Fund	-	-	-
Total Other Financing Sources (Uses)	<u>-</u>	<u>-</u>	<u>-</u>
Revenues and Other Financing Sources Over (Under) Uses	-	12,470	12,470
Fund Balance Appropriated	<u>-</u>	<u>-</u>	<u>-</u>
Net change in fund balance	\$ <u>-</u>	12,470	\$ <u>12,470</u>
Fund Balance:			
Beginning of Year, July 1		<u>221,405</u>	
End of Year, June 30		<u>\$ 233,875</u>	

**Camden County, North Carolina
Community Park Trust Fund
Schedule of Revenues, Expenditures, and
Changes in Fund Balances - Budget and Actual
For the Fiscal Year Ended June 30, 2016**

	2016		Variance Favorable (Unfavorable)
	Final Budget	Actual	
Revenues			
Restricted Intergovernmental	\$	\$ 227,492	\$
Local Contributions		-	
Investment earnings		687	
Total Revenue	<u>281,098</u>	<u>228,179</u>	<u>(52,919)</u>
Expenditures			
Operating expenses		-	
Capital outlay		322,097	
Total Expenditures	<u>322,172</u>	<u>322,097</u>	<u>75</u>
Revenues Over (Under) Expenditures	<u>(41,074)</u>	<u>(93,918)</u>	<u>(52,844)</u>
Other Financing Sources (Uses):			
Transfers from other funds	-	91,629	91,629
Proceeds from Lease Purchase	-	-	-
Total Other Financing Sources (Uses)	<u>-</u>	<u>91,629</u>	<u>91,629</u>
Revenues and Other Financing Sources Over (Under) Expenditures and Other Uses	<u>(41,074)</u>	<u>(2,289)</u>	<u>38,785</u>
Fund Balance Appropriated	<u>41,074</u>	<u>-</u>	<u>(41,074)</u>
Net change in fund balance	<u>\$ -</u>	<u>(2,289)</u>	<u>\$ (2,289)</u>
Fund Balance:			
Beginning of Year, July 1		<u>259,756</u>	
End of Year, June 30		<u>\$ 257,467</u>	

Camden County, North Carolina
Eco Dev Fund
Schedule of Revenues, Expenditures, and
Changes in Fund Balances - Budget and Actual
For the Fiscal Year Ended June 30, 2016

	2016		Variance Favorable (Unfavorable)
	Final Budget	Actual	
Revenues			
Local contributions	\$	\$ 40,000	\$
Investment earnings		805	
Total Revenue	<u>40,500</u>	<u>40,805</u>	<u>305</u>
Expenditures			
Operating expenses		19,000	
Capital outlay		-	
Total Expenditures	<u>40,500</u>	<u>19,000</u>	<u>21,500</u>
Revenues Over (Under) Expenditures	<u>-</u>	<u>21,805</u>	<u>21,805</u>
Other Financing Sources (Uses):			
Transfers from other funds	-	-	-
Proceeds from Lease Purchase	-	-	-
Total Other Financing Sources (Uses)	<u>-</u>	<u>-</u>	<u>-</u>
Revenues and Other Financing Sources Over (Under) Expenditures and Other Uses	-	21,805	21,805
Fund Balance Appropriated	<u>-</u>	<u>-</u>	<u>-</u>
Net change in fund balance	\$ <u>-</u>	21,805	\$ <u>21,805</u>
Fund Balance:			
Beginning of Year, July 1		<u>153,508</u>	
End of Year, June 30		<u>\$ 175,313</u>	

Camden County, North Carolina
School Fund
Schedule of Revenues, Expenditures, and
Changes in Fund Balances - Budget and Actual
For the Fiscal Year Ended June 30, 2016

	2016		Variance Favorable (Unfavorable)
	Final Budget	Actual	
Revenues			
Tax penalties and interest	\$	\$ 6,680	\$
Investment earnings		62	
Total Revenue	<u>3,850</u>	<u>6,742</u>	<u>2,892</u>
Expenditures			
Operating expenses		-	
Capital outlay		-	
Total Expenditures	<u>3,850</u>	<u>-</u>	<u>3,850</u>
Revenues Over (Under) Expenditures	<u>-</u>	<u>6,742</u>	<u>6,742</u>
Other Financing Sources (Uses):			
Transfers from other funds	-	-	-
Proceeds from Lease Purchase	-	-	-
Total Other Financing Sources (Uses)	<u>-</u>	<u>-</u>	<u>-</u>
Revenues and Other Financing Sources Over (Under) Expenditures and Other Uses	-	6,742	6,742
Fund Balance Appropriated	<u>-</u>	<u>-</u>	<u>-</u>
Net change in fund balance	\$ <u>-</u>	\$ 6,742	\$ <u>6,742</u>
Fund Balance:			
Beginning of Year, July 1		<u>7,070</u>	
End of Year, June 30		<u>\$ 13,812</u>	

Camden County, North Carolina
Revaluation Fund
Schedule of Revenues, Expenditures, and
Changes in Fund Balances - Budget and Actual
For the Fiscal Year Ended June 30, 2016

	2016		Variance Favorable (Unfavorable)
	Final Budget	Actual	
Revenues			
Ad Valorem taxes	\$	\$ -	\$
Investment earnings		2,085	
Total Revenue	<u>240,230</u>	<u>2,085</u>	<u>(238,145)</u>
Expenditures			
Operating expenses		36,795	
Capital outlay		-	
Total Expenditures	<u>240,230</u>	<u>36,795</u>	<u>203,435</u>
Revenues Over (Under) Expenditures	<u>-</u>	<u>(34,710)</u>	<u>(34,710)</u>
Other Financing Sources (Uses):			
Transfers from other funds		-	-
Proceeds from Lease Purchase		-	-
Total Other Financing Sources (Uses)	<u>-</u>	<u>-</u>	<u>-</u>
Revenues and Other Financing Sources Over (Under) Expenditures and Other Uses	<u>-</u>	<u>(34,710)</u>	<u>(34,710)</u>
Fund Balance Appropriated	<u>-</u>	<u>-</u>	<u>-</u>
Net change in fund balance	\$ <u>-</u>	\$ <u>(34,710)</u>	\$ <u>(34,710)</u>
Fund Balance:			
Beginning of Year, July 1		<u>394,600</u>	
End of Year, June 30		<u>\$ 359,890</u>	

CAPITAL PROJECTS FUNDS

Capital Projects Funds are used to account for the acquisition and construction of major capital facilities other than those financed by proprietary funds

Camden County, North Carolina
Scattered Housing Capital Projects Fund
Schedule of Revenues, Expenditures, and
Changes in Fund Balances - Budget and Actual
From Inception and For the Fiscal Year Ended June 30, 2016

	Project Author - ization	Prior Years	Actual Current Year	Total to Date	Variance Favorable (Unfavorable)
Revenues:					
Restricted - infrastructure hook-up 08-C-1844	\$ 37,289	\$ -	\$ -	\$ -	\$ -
Restricted - CDBG grant 11-C-2305	900,000	99,190	-	99,190	
Restricted - SRSF grant	350,000	-	-	-	
Total Revenues	<u>1,287,289</u>	<u>1,521,761</u>	<u>-</u>	<u>1,521,761</u>	<u>234,472</u>
Expenditures:					
Current:					
Economic and physical development:	<u>1,287,289</u>	<u>1,517,363</u>	<u>-</u>	<u>1,517,363</u>	<u>(230,074)</u>
Revenues over expenditures	<u>-</u>	<u>4,398</u>	<u>-</u>	<u>4,398</u>	<u>4,398</u>
Other Financing Sources (Uses):					
Transfers in (out)	-	-	-	-	-
Local contribution	-	2,132	-	2,132	(2,132)
Total Other Financing Sources (Uses)	<u>-</u>	<u>2,132</u>	<u>-</u>	<u>2,132</u>	<u>(2,132)</u>
Net change in fund balance	<u>\$ -</u>	<u>\$ 6,530</u>	<u>\$ -</u>	<u>\$ 6,530</u>	<u>\$ 6,530</u>
Fund Balance:					
Beginning of Year, July 1			<u>6,530</u>		
End of Year, June 30			<u>\$ 6,530</u>		

PROPRIETARY FUNDS

Enterprise Funds are used to account for operations that are financed and operated in a manner similar to private business enterprises - where the intent of the governing body is that the costs of providing goods and services to the general public on a continuing basis be financed or recovered primarily through user charges; or where the governing body has decided that periodic determination of net income is appropriate for accountability purposes.

Camden County, North Carolina
Enterprise Fund - Water & Sewer District
Schedule of Revenues and Expenditures
Budget and Actual - (Non-GAAP)
For the Fiscal Year Ended June 30, 2016

	2016		Variance Positive (Negative)
	Final Budget	Actual	
Revenues:			
Operating Revenues			
Water sales	\$	\$ 1,049,348	\$
Tap on Fees		42,350	
Penalties		40,800	
Miscellaneous		-	
Total water sales	<u>1,136,669</u>	<u>1,132,498</u>	<u>(4,171)</u>
Waste water sales		373,752	
Miscellaneous		-	
Total waste water sales	<u>582,906</u>	<u>373,752</u>	<u>(209,154)</u>
Total Operating Revenues	<u>1,719,575</u>	<u>1,506,250</u>	<u>(213,325)</u>
Nonoperating Revenues			
Interest on Investments	<u>3,300</u>	<u>4,386</u>	<u>1,086</u>
Total Revenues	<u>1,722,875</u>	<u>1,510,636</u>	<u>(212,239)</u>
Expenditures:			
Reverse osmosis plant			
Salaries and employee benefits		163,846	
Repairs and maintenance		25,420	
Chemicals		32,420	
Utilities		76,738	
Operating expenses		84,163	
Total	<u>415,395</u>	<u>382,587</u>	<u>32,808</u>
Water distribution:			
Salaries and employee benefits		215,760	
Repairs and maintenance		66,539	
Supplies		13,614	
Contracted services		29,023	
Operating expenses		74,527	
Total	<u>423,824</u>	<u>399,463</u>	<u>24,361</u>
Waste Water treatment:			
Salaries and employee benefits		129,685	
Repairs and maintenance		22,104	
Utilities		29,347	
Contracted services		6,943	
Supplies		16,214	
Operating expenses		44,996	
Total	<u>281,676</u>	<u>249,289</u>	<u>32,387</u>

Camden County, North Carolina
Enterprise Fund - Water & Sewer District
Schedule of Revenues and Expenditures
Budget and Actual - (Non-GAAP)
For the Fiscal Year Ended June 30, 2016

	2016		Variance Positive (Negative)
	Final Budget	Actual	
Budgetary Appropriations:			
Capital Outlay		312,614	
Interest Paid		63,007	
Debt Principal		223,424	
Total	<u>601,980</u>	<u>599,045</u>	<u>2,935</u>
Total Expenditures	<u>1,722,875</u>	<u>1,630,384</u>	<u>92,491</u>
Revenues Over (Under) Expenditures	<u>-</u>	<u>(119,748)</u>	<u>(119,748)</u>
Other Financing Sources and (Uses):			
Debt Proceeds	-	-	-
Capital Contributions	-	-	-
Transfer from other funds	-	1,157,000	-
Total Other Financing Sources (Uses)	<u>-</u>	<u>1,157,000</u>	<u>1,157,000</u>
Revenues and Other Sources Over (Under) Expenses and Other Uses	-	1,037,252	1,037,252
Appropriated Fund Balance	<u>-</u>	<u>-</u>	<u>-</u>
Revenues, Other Sources and Appropriated Fund Balance Over (Under) Expenditures and Other Uses	<u>\$ -</u>	<u>\$ 1,037,252</u>	<u>\$ 1,037,252</u>

Reconciliation from Budgetary Basis (Modified Accrual) to Full Accrual:

Revenues, Other Sources and Appropriated Fund Balance Over (Under) Expenditures and Other Uses	<u>\$ 1,037,252</u>
Reconciling items:	
Capital Outlay	312,614
Principal Payments	223,424
Change in accrued vacation pay	(7,426)
Increase (decrease) in net pension asset	(28,827)
(Increase) decrease in net pension liability	(21,838)
Increase (decrease) in deferred outflows of resources for pensions	(1,523)
(Increase) decrease in deferred inflows of resources for pensions	58,908
Other revenues from capital projects	445,900
Change in accrued OPEB	(14,071)
Change in accrued interest	544
Depreciation	(541,905)
Total reconciling items	<u>425,800</u>
Change in net position	<u>\$ 1,463,052</u>

Attachment: 2015-2016 Camden County Audit (1494 : FY 15-16 Audit by Greg Allison of Thompson, Price, Scott, Adams, & Co., PA)

Camden County, North Carolina
Water and Sewer District Capital Projects Fund
Schedule of Revenues, Expenditures, and
Changes in Fund Balances - Budget and Actual
From Inception and For the Fiscal Year Ended June 30, 2016

	Project Author - ization	Actual		Total to Date	Variance Favorable (Unfavorable)
		Prior Years	Current Year		
Revenues:					
Restricted intergovernmental - Rural Center	\$ 3,400,000	\$ 3,489,950	\$ -	\$ 3,489,950	\$ 89,950
Restricted intergovernmental - CWMTF Funds	3,564,011	3,096,007	-	3,096,007	(468,004)
Restricted intergovernmental - CDBG	600,000	600,000	-	600,000	-
Other	75,905	263,062	445,900	708,962	633,057
Interest Income	-	9,377	1,710	11,087	11,087
Total Revenues	7,639,916	7,458,396	447,610	7,906,006	266,090
Expenditures:					
Sewer Construction:					
Legal fees	94,189	51,292	-	51,292	42,897
Land	422,900	70,360	-	70,360	352,540
Engineering	753,855	323,855	-	323,855	430,000
Collection system	1,506,029	1,443,078	20,000	1,463,078	42,951
Construction	6,818,822	6,818,231	-	6,818,231	591
Spray fields	1,133,161	302,362	-	302,362	830,799
Fund reserves	360,943	73,448	-	73,448	287,495
Total	11,089,899	9,082,626	20,000	9,102,626	1,987,273
Revenues over expenditures	(3,449,983)	(1,624,230)	427,610	(1,196,620)	2,253,363
Other Financing Sources (Uses):					
Fund balance appropriated	1,132,861	-	-	-	1,132,861
Revolving loan funds	1,367,122	1,307,809	-	1,307,809	59,313
Transfers In	950,000	582,291	-	582,291	367,709
Total Other Financing Sources (Uses)	3,449,983	1,890,100	-	1,890,100	1,559,883
Revenues, Other Sources Over (Under) Expenditures and Other Uses	\$ -	\$ 265,870	427,610	\$ 693,480	\$ 693,480

Attachment: 2015-2016 Camden County Audit (1494 : FY 15-16 Audit by Greg Allison of Thompson, Price, Scott, Adams, & Co., PA)

Camden County, North Carolina
Water and Sewer District Capital Projects Fund
Schedule of Revenues, Expenditures, and
Changes in Fund Balances - Budget and Actual
From Inception and For the Fiscal Year Ended June 30, 2016

	Project Author - ization	Actual		Total to Date	Variance Favorable (Unfavorable)
		Prior Years	Current Year		
Revenues:					
Restricted intergovernmental - CWMTF	\$ 1,464,100	\$ 1,217,666	\$ -	\$ 1,217,666	\$ (246,434)
Restricted intergovernmental - RC Grant	649,875	693,600	-	693,600	43,725
Restricted intergovernmental - DOT Grant	269,810	276,868	-	276,868	7,058
Other	-	18,367	-	18,367	18,367
Interest Income	-	-	537	537	537
Total Revenues	2,383,785	2,206,501	537	2,207,038	(176,747)
Expenditures:					
Sewer improvements	2,419,510	2,288,746	-	2,288,746	130,764
Professional services	115,000	16,764	-	16,764	98,236
Fund reserves	-	-	-	-	-
Total	2,534,510	2,305,510	-	2,305,510	229,000
Revenues over expenditures	(150,725)	(99,009)	537	(98,472)	52,253
Other Financing Sources (Uses):					
Fund balance appropriated	35,725	-	-	-	(35,725)
Transfers In	115,000	150,725	1,157,000	1,307,725	1,192,725
Total Other Financing Sources (Uses)	150,725	150,725	1,157,000	1,307,725	1,157,000
Revenues, Other Sources Over (Under) Expenditures and Other Uses	\$ -	\$ 51,716	1,157,537	\$ 1,209,253	\$ (1,104,747)

Attachment: 2015-2016 Camden County Audit (1494 : FY 15-16 Audit by Greg Allison of Thompson, Price, Scott, Adams, & Co., PA)

AGENCY FUNDS

Agency funds are used to account for assets the County holds on behalf of others.

Camden County, North Carolina
Agency Funds
Combining Statement of Changes in Assets and Liabilities
For the Fiscal Year Ended June 30, 2016

	<u>Balance</u> <u>July 1, 2015</u>	<u>Net</u> <u>Change</u>	<u>Balance</u> <u>June 30, 2016</u>
Social Services Fund:			
Cash and Investments	\$ <u>10,699</u>	\$ <u>(1,819)</u>	\$ <u>8,880</u>
Liabilities	\$ <u>10,699</u>	\$ <u>(1,819)</u>	\$ <u>8,880</u>
Nancy M. and H. Clay Ferebee Fund			
Cash and Investments	\$ <u>1,534</u>	\$ <u>4</u>	\$ <u>1,538</u>
Liabilities	\$ <u>1,534</u>	\$ <u>4</u>	\$ <u>1,538</u>
Total - All Agency Funds:			
Cash and Investments	\$ <u>12,233</u>	\$ <u>(1,815)</u>	\$ <u>10,418</u>
Liabilities	\$ <u>12,233</u>	\$ <u>(1,815)</u>	\$ <u>10,418</u>

OTHER SCHEDULES

This section includes additional information on property taxes.

- Schedule of Ad Valorem Taxes Receivable
- Analysis of Current Tax Levy
- Secondary Market Disclosures
- Ten Largest Taxpayers

Camden County, North Carolina
Analysis of Current Tax Levy
County - Wide Levy
For the Fiscal Year Ended June 30, 2016

	County - wide			Total Levy	
	Property Valuation	Rate	Amount of Levy	Property excluding Registered Motor Vehicles	Registered Motor Vehicles
Original levy:					
Property Taxes at Current Year Rate	\$ 1,057,712,647	0.6800%	\$ 7,192,446	\$ 6,542,010	\$ 650,436
Total Original Levy	<u>1,057,712,647</u>		<u>7,192,446</u>	<u>6,542,010</u>	<u>650,436</u>
Discoveries:					
Current year taxes	-	0.6800%	-	-	-
Total Discoveries	<u>-</u>		<u>-</u>	<u>-</u>	<u>-</u>
Abatements					
Current Year Taxes	-	0.6800%	-	-	-
Total Abatements	<u>-</u>		<u>-</u>	<u>-</u>	<u>-</u>
Total for Year	<u>\$ 1,057,712,647</u>		7,192,446	6,542,010	650,436
Uncollected taxes at June 30, 2016			<u>180,619</u>	<u>180,619</u>	<u>-</u>
Current year's taxes collected			<u>\$ 7,011,827</u>	<u>\$ 6,361,391</u>	<u>\$ 650,436</u>
Current levy collection percentage			<u>97.49%</u>	<u>97.24%</u>	<u>100.00%</u>

Attachment: 2015-2016 Camden County Audit (1494 : FY 15-16 Audit by Greg Allison of Thompson, Price, Scott, Adams, & Co., PA)

**Camden County, North Carolina
Analysis of Current Tax Levy
County - wide Levy
For the Fiscal Year Ended June 30, 2016**

Secondary Market Disclosures:

Assessed Valuation:	
Assessment Ratio ¹	100 %
Real Property	\$ 901,454,076
Personal Property ³	132,110,309
Public Service Companies ²	<u>24,148,274</u>
Total Assessed Valuation	<u>1,057,712,659</u>
Tax Rate per \$100	0.68
Levy (includes discoveries, releases and abatements) ³	<u>\$ 7,192,446</u>

In addition to the County-wide rate, the following table lists the levies by the County on behalf and fire protection districts for the fiscal year ended June 30:

Fire Protection Districts	<u>\$ 111,986</u>
---------------------------	-------------------

¹ Percentage of appraised value has been established by statute.

² Valuation of railroads, telephone companies and other utilities as determined by the North Carolina Property Tax Commission.

³ The levy includes penalties and multi-rate for motor vehicles.

**Camden County, North Carolina
Schedule of Ten Largest Taxpayers
For the Fiscal Year Ended June 30, 2016**

Taxpayer	Type of Business	2015 Assessed Valuation	Percentage of Total Assessed Valuation
E & J Holding LLC	Training Facility	\$ 44,686,618	4.22%
George Wood Farms, Inc.	Farm	14,489,853	1.37%
Albemarle Elec Membership Corp	Utility	9,865,000	0.93%
Dominion North Carolina Power	Utility	6,706,471	0.63%
Blue Sky Development, LLC	Apartment Complex	6,109,853	0.58%
Academi Training Center, Inc.	Training Facility	3,769,412	0.36%
Carolina Telephone & Telegraph	Utility	2,681,029	0.25%
Abner Wayne Staples	Farm	2,617,059	0.25%
John E Ferbee Farming, Inc.	Farm	2,427,206	0.23%
Cherry Hill Farms	Farm	2,345,882	0.22%
Total		<u><u>\$ 95,698,383</u></u>	<u><u>9.05%</u></u>

COMPLIANCE SECTION



Thompson, Price, Scott, Adams & Co., P.A.
 4024 Oleander Drive Suite 3
 Wilmington, North Carolina 28403
 Telephone (910) 791-4872
 Fax (910) 395-4872

**Report On Internal Control Over Financial Reporting And On Compliance and Other
 Matters Based On An Audit Of Financial Statements Performed In Accordance With
 Government Auditing Standards**

Independent Auditors' Report

To the Board of County Commissioners
 Camden County, North Carolina

We have audited, in accordance with the auditing standards generally accepted in the United States of America and the standards applicable to the financial audits contained in *Government Auditing Standards* issued by the Comptroller General of the United States, the accompanying financial statements of the governmental activities, the business-type activities, the discretely presented component unit, each major fund, and the aggregate remaining fund information of Camden County, as of and for the year ended June 30, 2016, and the related notes to the financial statements, which collectively comprises the Camden County's basic financial statements, and have issued our report thereon dated December 20, 2016. Our report includes a reference to other auditors who audited the financial statements of the Camden County ABC Board, as described in our report on Camden County's financial statements. This report does not include the results of the other auditors' testing of internal control over financial reporting or compliance and other matters that are reported separately by those auditors. The financial statements of Camden County ABC Board and Camden County TDA were not audited in accordance with *Government Auditing Standards*.

Internal Control Over Financial Reporting

In planning and performing our audit of the financial statements, we considered Camden County's internal control over financial reporting (internal control) to determine the audit procedures that are appropriate in the circumstances for the purpose of expressing our opinions on the financial statements, but not for the purpose of expressing an opinion on the effectiveness of the Camden County's internal control. Accordingly, we do not express an opinion on the effectiveness of the Commission's internal control.

A deficiency in internal control exists when the design or operation of a control does not allow management or employees, in the normal course of performing their assigned functions, to prevent or detect and correct misstatements on a timely basis. A material weakness is a deficiency, or a combination of deficiencies, in internal control, such that there is a reasonable possibility that a material misstatement of the entity's financial statements will not be

Members

American Institute of CPAs – N.C. Association of CPAs – AICPA Division of Firms

prevented, or detected and corrected on a timely basis. A significant deficiency is a deficiency, or a combination of deficiencies, in internal control that is less severe than a material weakness, yet important enough to merit attention by those charged with governance.

Our consideration of the internal control was for limited purpose described in the first paragraph of this section and was not designed to identify all deficiencies in internal control that might be material weaknesses or significant deficiencies. Given these limitations, during our audit we did not identify any deficiencies in internal control that we consider to be material weaknesses. However, material weaknesses may exist that have not been identified.

Compliance and Other Matters

As part of obtaining reasonable assurance about whether Camden County's financial statements are free of material misstatement, we performed tests of its compliance with certain provisions of laws, regulations, contracts, and grant agreements, noncompliance with which could have a direct and material effect on the determination of financial statement amounts. However, providing an opinion on compliance with those provisions was not an objective of our audit, and accordingly, we do not express such an opinion. The results of our tests disclosed no instances of noncompliance or other matters that are required to be reported under *Government Auditing Standards*.

Purpose of this Report

The purpose of this report is solely to describe the scope of our testing of internal control and compliance and the results of that testing, and not to provide an opinion on the effectiveness of the entity's internal control or on compliance. This report is an integral part of an audit performed in accordance with *Government Auditing Standards* in considering the entity's internal control and compliance. Accordingly, this communication is not suitable for any other purpose.

Thompson, Price, Scott, Adams & Co., P.A.

Thompson, Price, Scott, Adams & Co., P.A.

Wilmington, North Carolina

December 20, 2016

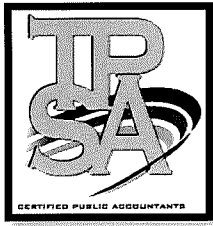

Thompson, Price, Scott, Adams & Co., P.A.
 4024 Oleander Drive Suite 3
 Wilmington, North Carolina 28403
 Telephone (910) 791-4872
 Fax (910) 395-4872

Report on Compliance for Each Major Federal Program; Report on Internal Control Over Compliance; With OMB Uniform Guidance and the State Single Audit Implementation Act

Independent Auditors' Report

To the Board of County Commissioners
 Camden County, North Carolina

Report on Compliance for Each Major Federal Program

We have audited Camden County, compliance with the types of compliance requirements described in the *OMB Compliance Supplement* and the *Audit Manual for Governmental Auditors in North Carolina*, issued by the Local Government Commission, that could have a direct and material effect on each of Camden County' major federal programs for the year ended June 30, 2016. Camden County' major federal programs are identified in the summary of auditor's results section of the accompanying schedule of findings and questioned costs.

Management's Responsibility

Management is responsible for compliance with the requirements of laws, regulations, contracts, and grants applicable to its federal programs.

Auditors' Responsibility

Our responsibility is to express an opinion on compliance for each of Camden County' major federal programs based on our audit of the types of compliance requirements referred to above. We conducted our audit of compliance in accordance with auditing standards generally accepted in the United States of America; the standards applicable to financial audits contained in *Government Auditing Standards*, issued by the Comptroller General of the United States; and the audit requirements of Title 2 U.S. *Code of Federal Regulations* Part 200, *Uniform Administrative Requirements, Cost Principles, and Audit Requirements for Federal Awards* (Uniform Guidance) and the State Single Audit Implementation Act. Those standards, the Uniform Guidance, and the State Single Audit Implementation Act require that we plan and perform the audit to obtain reasonable assurance about whether noncompliance with the types of compliance requirements referred to above that could have a direct and material effect on a major federal program occurred. An audit includes examining, on a test basis, evidence about Camden County' compliance with those requirements and performing such other procedures, as we considered necessary in the circumstances.

We believe that our audit provides a reasonable basis for our opinion on compliance for each major federal program. However, our audit does not provide a legal determination of Camden County' compliance.

Members
 American Institute of CPAs – N.C. Association of CPAs – AICPA Division of Firms

Opinion on Each Major Federal Program

In our opinion, Camden County complied, in all material respects, with the types of compliance requirements referred to above that could have a direct and material effect on each of its major federal programs for the year ended June 30, 2016.

Report on Internal Control Over Compliance

Management of Camden County is responsible for establishing and maintaining effective internal control over compliance with the types of compliance requirements referred to above. In planning and performing our audit of compliance, we considered Camden County' internal control over compliance with the types of requirements that could have a direct and material effect on a major federal program to determine the auditing procedures that are appropriate in the circumstances for the purpose of expressing our opinion on compliance for each major federal program and to test and report on internal control over compliance in accordance with the Uniform Guidance, but not for the purpose of expressing an opinion on the effectiveness of internal control over compliance. Accordingly, we do not express an opinion on the effectiveness of the Council's internal control over compliance.

A deficiency *in internal control over compliance* exists when the design or operation of a control over compliance does not allow management or employees, in the normal course of performing their assigned functions, to prevent, or detect and correct, noncompliance with a type of compliance requirement of a federal program on a timely basis. A *material weakness in internal control over compliance* is a deficiency, or a combination of deficiencies, in internal control over compliance, such that there is a reasonable possibility that material noncompliance with a type of compliance requirement of a federal program will not be prevented, or detected and corrected, on a timely basis. A *significant deficiency in internal control over compliance* is a deficiency, or combination of deficiencies, in internal control over compliance with a type of compliance requirement of a federal program that is less severe than a material weakness in internal control over compliance, yet important enough to merit attention by those charged with governance.

Our consideration of internal control over compliance was for the limited purpose described in the first paragraph of this section and was not designed to identify all deficiencies in internal control over compliance that might be significant deficiencies or material weaknesses. We did not identify any deficiencies in internal control over compliance that we consider to be material weaknesses. However, material weaknesses may exist that have not been identified.

The purpose of this report on internal control over compliance is solely to describe the scope of our testing of internal control over compliance and the results of that testing based on the requirements of the Uniform Guidance. Accordingly, this report is not suitable for any other purpose.

Thompson, Price, Scott, Adams & Co., P.A.

Thompson, Price, Scott, Adams & Co., P.A.

Wilmington, North Carolina

December 20, 2016



Thompson, Price, Scott, Adams & Co., P.A.
 4024 Oleander Drive Suite 3
 Wilmington, North Carolina 28403
 Telephone (910) 791-4872
 Fax (910) 395-4872

Report On Compliance For Each Major State Program; Report on Internal Control Over Compliance; In accordance with OMB Uniform Guidance; and the State Single Audit Implementation Act

Independent Auditors' Report

To the Board of County Commissioners
 Camden County, North Carolina

Report on Compliance for Each Major State Program

We have audited Camden County, North Carolina, compliance with the types of compliance requirements described in the *Audit Manual for Governmental Auditors in North Carolina*, issued by the Local Government Commission, that could have a direct and material effect on each of Camden County's major state programs for the year ended June 30, 2016. Camden County's major state programs are identified in the summary of auditor's results section of the accompanying schedule of findings and questioned costs.

Management's Responsibility

Management is responsible for compliance with the requirements of laws, regulations, contracts, and grants applicable to its state programs.

Auditors' Responsibility

Our responsibility is to express an opinion on compliance for each of Camden County's major state programs based on our audit of the types of compliance requirements referred to above. We conducted our audit of compliance in accordance with auditing standards generally accepted in the United States of America; the standards applicable to financial audits contained in *Government Auditing Standards*, issued by the Comptroller General of the United States; and applicable sections of Title 2 US Code of Federal Regulations Part 200, *Uniform Administrative Requirements, Cost Principles, and Audit Requirements for Federal Awards* (Uniform Guidance), as described in the *Audit Manual for Governmental Auditors in North Carolina*, and the State Single Audit Implementation Act. Those standards, Uniform Guidance, and the State Single Audit Implementation Act require that we plan and perform the audit to obtain reasonable assurance about whether noncompliance with the types of compliance requirements referred to above that could have a direct and material effect on a major state program occurred. An audit includes examining, on a test basis, evidence about Camden County' compliance with those requirements and performing such other procedures, as we considered necessary in the circumstances.

We believe that our audit provides a reasonable basis for our opinion on compliance for each major state program. However, our audit does not provide a legal determination of Camden County compliance.

Opinion on Each Major State Program

In our opinion, Camden County complied, in all material respects, with the types of compliance requirements referred to above that could have a direct and material effect on each of its major state programs for the year ended June 30, 2016.

Report on Internal Control Over Compliance

Management of Camden County is responsible for establishing and maintaining effective internal control over compliance with the types of compliance requirements referred to above. In planning and performing our audit of compliance, we considered Camden County' internal control over compliance with the types of requirements that could have a direct and material effect on a major state program to determine the auditing procedures that are appropriate in the circumstances for the purpose of expressing our opinion on compliance for each major state program and to test and report on internal control over compliance in accordance with the Uniform Guidance, but not for the purpose of expressing an opinion on the effectiveness of internal control over compliance. Accordingly, we do not express an opinion on the effectiveness of the Council's internal control over compliance.

A deficiency in internal control over compliance exists when the design or operation of a control over compliance does not allow management or employees, in the normal course of performing their assigned functions, to prevent, or detect and correct, noncompliance with a type of compliance requirement of a state program on a timely basis. A material weakness in internal control over compliance is a deficiency, or a combination of deficiencies, in internal control over compliance, such that there is a reasonable possibility that material noncompliance with a type of compliance requirement of a state program will not be prevented, or detected and corrected, on a timely basis. A significant deficiency in internal control over compliance is a deficiency, or combination of deficiencies, in internal control over compliance with a type of compliance requirement of a state program that is less severe than a material weakness in internal control over compliance, yet important enough to merit attention by those charged with governance.

Our consideration of internal control over compliance was for the limited purpose described in the first paragraph of this section and was not designed to identify all deficiencies in internal control over compliance that might be significant deficiencies or material weaknesses. We did not identify any deficiencies in internal control over compliance that we consider to be material weaknesses. However, material weaknesses may exist that have not been identified.

The purpose of this report on internal control over compliance is solely to describe the scope of our testing of internal control over compliance and the results of that testing based on the requirements of Uniform Guidance. Accordingly, this report is not suitable for any other purpose.

Thompson, Price, Scott, Adams & Co., P.A.

Thompson, Price, Scott, Adams & Co., P.A.

Wilmington, North Carolina

December 20, 2016

**Camden County, North Carolina
Schedule of Findings and Questioned Costs
For the Fiscal Year Ended June 30, 2016**

Section II. Financial Statement Findings

None Reported.

Section III. Federal Award Findings and Question Costs

None Reported.

Section IV. State Award Findings and Question Costs

None Reported.

**Camden County, North Carolina
Corrective Action Plan
For the Fiscal Year Ended June 30, 2016**

Section II. Financial Statement Findings

None Reported.

Section III. Federal Award Findings and Question Costs

None Reported.

Section IV. State Award Findings and Question Costs

None Reported.

**Camden County, North Carolina
Summary Schedule of Prior Year Audit Findings
For the Year Ended June 30, 2016**

None Reported.

Attachment: 2015-2016 Camden County Audit (1494 : FY 15-16 Audit by Greg Allison of Thompson, Price, Scott, Adams, & Co., PA)

Camden County, North Carolina
 Schedule of Expenditures of Federal and State Awards
 For the Year Ended June 30, 2016

Grantor/Pass-through Grantor/Program Title	Federal CFDA Number	Fed. (Direct & Pass-through) Expenditures	State Expenditures	Passed-through to Subrecipients	Local Expenditures
Federal Awards:					
<u>U.S. Dept. of Agriculture</u>					
Passed-through the N.C. Dept. of Health and Human Services:					
Division of Social Services:					
Administration:					
State Administrative Matching Grants for the Supplemental Nutrition Assistance Program	10.561	\$ 90,501	\$ -	\$ -	\$ 90,501
Passed-through the N.C. Dept. of Health and Human Services:					
Division of Public Health:					
Direct Benefit Payments:					
Special Supplemental Nutrition Program for Women, Infants, & Children	10.557	15,286	-	-	-
Total U.S. Dept. of Agriculture		<u>105,787</u>	<u>-</u>	<u>-</u>	<u>90,501</u>
<u>U.S. Dept. of Justice</u>					
Direct Program:					
Passed-through N.C. Dept. Public Safety					
JAG Program Cluster					
Edward Byrne Memorial Justice Assistance Grant	16.738	8,051	-	-	-
Total U.S. Dept. of Justice					
<u>U.S. Dept. of Health & Human Services</u>					
Passed-through the N.C. Dept. of Health and Human Services:					
Division of Social Services					
Temporary Assistance for Needy Families Cluster					
Work First Administration	93.558	24,768	-	-	25,269
Work First Service	93.558	60,685	-	-	64,781
TANF Payment and Penalties	93.558	30,573	-	-	-
Total TANF Cluster		<u>116,026</u>	<u>-</u>	<u>-</u>	<u>90,050</u>
Child Support Enforcement Section	93.563	40,765	-	-	21,000
Low-Income Home Energy Assistance:					
Administration	93.568	3,826	-	-	-
Energy Assistance Payments- Direct Benefit Payments	93.568	23,200	-	-	-
Crisis Intervention Program	93.568	22,919	-	-	-
Stephanie Tubbs Jones Child Welfare Services-State Grants					
- Permanency Planning - Families for Kids	93.645	928	-	-	309
Social Services Block Grant - Other Service and Training	93.667	28,994	3,104	-	10,699
In Home Services	93.667	606	-	-	87

Camden County, North Carolina
 Schedule of Expenditures of Federal and State Awards
 For the Year Ended June 30, 2016

Grantor/Pass-through Grantor/Program Title	Federal CFDA Number	Fed. (Direct & Pass-through) Expenditures	State Expenditures	Passed-through to Subrecipients	Local Expenditures
Foster Care and Adoption Cluster:(Note 2)					
Title IV-E Foster Care-Administration	93.658	10,595	2,211	-	9,389
Foster Care-Direct Benefit Payments	93.658	4,451	7,739	-	2,411
Adoption Assistance-Direct Benefit Payments	93.659	19,286	4,936	-	4,936
Total Foster Care and Adoption Cluster		34,332	14,886	-	16,736
Division of Child Development: Subsidized Child Care (Note 3) <u>Child Care Development Fund Cluster</u>					
Division of Social Services and Early Education: Child Care Development Fund-Administration	93.596	64,445	-	-	-
Division of Child Development: Child Care and Development Block Grant	93.575	60,515	-	-	-
Child Care and Development Fund - Mandatory	93.596	20,465	-	-	-
Child Care and Development Fund - Match	93.596	6,774	-	-	-
Total Child Care Development Fund Cluster		152,199	-	-	-
Foster Care IV-E	93.658	1,749	900	-	-
Temporary Assistance for Needy Families	93.558	17,226	-	-	-
State Appropriations		-	6,997	-	-
TANF - MOE		-	5,094	-	-
Total Subsidized Child Care Cluster		171,174	12,991	-	-
Passed-through the N.C. Dept. of Health and Human Services: Division of Medical Assistance: Direct Benefit Payments:					
Medical Assistance Program	93.778	4,245,225	2,347,451	-	-
State Children's Insurance Program - N.C. Health Choice	93.767	171,026	8,019	-	125
CMS Research (MIPPA Grant)	93.779	640	-	-	-
Division of Social Services: Administration:					
Medical Assistance Program	93.778	356,905	908	-	147,143
State Children's Insurance Program - N.C. Health Choice	93.767	20,214	1,258	-	125
Total U.S. Dept. of Health and Human Services		5,236,780	2,388,617	-	286,274
Total Federal Awards		5,350,618	2,388,617	-	376,775

Camden County, North Carolina
 Schedule of Expenditures of Federal and State Awards
 For the Year Ended June 30, 2016

Grantor/Pass-through Grantor/Program Title State Awards:	Federal CFDA Number	Fed. (Direct & Pass-through) Expenditures	State Expenditures	Passed-through to Subrecipients	Local Expenditures
<u>N.C. Dept. of Health and Human Services</u>					
Division of Aging and Adult Services:					
County Funded Programs/Non Allocating costs		-	-	-	109,846
State/County Special Assistance for Adults		-	53,314	-	53,314
Passed through Albemarle Commission:					
Senior Center Grant		-	5,229	-	-
Nutrition Grant		-	7,470	-	-
Division of Social Services:					
State Foster Care Benefits Program		-	8,145	-	8,145
 Total N. C. Department of Health and Human Services		-	74,158	-	171,305
<u>N.C. Dept. of Public Safety</u>					
Juvenile Crime Prevention Program		-	51,907	-	-
<u>N.C. Dept. of Agriculture</u>					
Soil and Water Technical Assistance		-	23,125	-	-
<u>N.C. Dept. of Transportation</u>					
Camden ECO Park Access Road		-	-	-	-
Dismal Swamp Welcome/Visitor Center	DOT - 13	-	142,857	-	-
Total N. C. Dept. Of Transportation		-	142,857	-	-
<u>N.C. Dept. of Public Instruction</u>					
Public School Building Capital Fund Lottery Proceeds		-	44,840	44,840	-
<u>N.C. Department of Environment and Natural Resources</u>					
White Goods Grant		-	3,487	-	-
Soil and Water Conservation Funds		-	3,600	-	-
Solid Waste Disposal		-	8,153	-	-
Park and Recreation Trust Fund		-	65,000	-	-
Scrap Tire Grant		-	5,055	-	-
Total N.C. Dept. EHNR		-	85,295	-	-
<u>N.C. Dept. of Insurance</u>					
SHIIP Gant		-	3,279	-	-
South Mills Fire Grant		-	-	-	-
Total N.C. Dept. of Insurance		-	3,279	-	-
 Total State Awards		-	425,461	44,840	171,305
 Total Federal and State Awards		\$ 5,350,618	\$ 2,814,078	\$ 44,840	\$ 548,080

Attachment: 2015-2016 Camden County Audit (1494 : FY 15-16 Audit by Greg Allison of Thompson, Price, Scott, Adams, & Co., PA)

Camden County, North Carolina
Schedule of Expenditures of Federal and State Awards
For the Year Ended June 30, 2016

Grantor/Pass-through Grantor/Program Title	Federal CFDA Number	Fed. (Direct & Pass-through) Expenditures	State Expenditures	Passed-through to Subrecipients	Local Expenditures
-----------------------------------------------	---------------------------	-------------------------------------------------	-----------------------	---------------------------------------	-----------------------

Notes to the Schedule of Expenditures of Federal and State Financial Awards:

Note 1: Basis of Presentation

The accompanying schedule of expenditures of federal and State awards (SEFSA) includes the federal and State grant activity of the Camden County under the programs of the federal government and the State of North Carolina for the year ended June 30, 2016. The information in this SEFSA is presented in accordance with the requirements of Title 2 US Code of Federal Regulations Part 200, Uniform Administrative Requirements, Cost Principles, and Audit Requirements for Federal Awards and the State Single Audit Implementation Act. Because the Schedule presents only a selected portion of the operations of Camden County, it is not intended to and does not present the financial position, changes in net position or cash flows of Camden County.

Note 2: Summary of Significant Accounting Policies

Expenditures reported in the SEFSA are reported on the modified accrual basis of accounting. Such expenditures are recognized following the cost principles contained in Uniform Guidance, wherein certain types of expenditures are not allowable or are limited as to reimbursement. Camden County has elected not to use the 10-percent de minimis indirect cost rate as allowed under the Uniform Guidance.

Note 3: Cluster of Programs

The following are clustered by the NC Department of Health and Human Services and are treated separately for state audit requirement purposes: Subsidized Child Care, TANF, and Foster Care and Adoption.

Attachment: 2015-2016 Camden County Audit (1494 : FY 15-16 Audit by Greg Allison of Thompson, Price, Scott, Adams, & Co., PA)

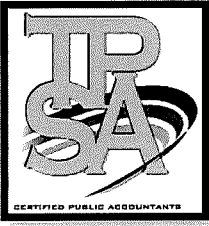

Thompson, Price, Scott, Adams & Co., P.A.
 4024 Oleander Drive Suite 103
 Wilmington, NC 28403

December 20, 2016

The Honorable Beth A. Wood, CPA, State Auditor
 Office of the State Auditor
 2 South Salisbury Street
 20601 Mail Service Center
 Raleigh, North Carolina 27699-0601

Dear Ms. Wood:

This letter is provided in connection with your audit of the State of North Carolina's Schedule of Expenditures of Federal Awards and compliance over its major federal programs for the period ended June 30, 2016 for the purpose of expressing an opinion on whether the State complied, in all material respects, with the compliance requirements that could have a direct and material effect on each of its major federal programs for the year ended June 30, 2016.

We have audited those federal programs as checked off on the list that follows of Camden County as major programs in accordance with *Uniform Grant Guidance* for the year ended June 30, 2016:

- | | | |
|---|-------------------------------------|--------------------------------------------------------------|
| A | <input type="checkbox"/> | CFDA # 93.558 Temporary Assistance for Needy Families (TANF) |
| B | <input type="checkbox"/> | CFDA # 93.767 Children's Health Insurance Program (CHIP) |
| C | <input checked="" type="checkbox"/> | CFDA # 93.778 Medical Assistance Program (Medicaid) |

We acknowledge that:

1. We are independent with respect to Camden County and to the State of North Carolina under the requirements of the American Institute of Certified Public Accountants (AICPA), and if applicable, *Government Auditing Standards* issued by the U.S. Government Accountability Office. Also, we complied with all ethical requirements promulgated by these professional bodies, as applicable.
2. We are aware that the results of our audit of Camden County will be included in the *Report on Compliance with Requirements Applicable to Each Major Program and on Internal Control Over Compliance in Accordance with the Uniform Administrative Requirements, Cost Principles, and Audit Requirements for Federal Grants* of the State of North Carolina and that you intend to place reliance on our audit of the above designated program(s).

3. We are familiar with accounting principles generally accepted in the United States of America and with generally accepted auditing standards promulgated by the AICPA and with GAO *Government Auditing Standards* and will report and conduct our audit in accordance therewith.
4. We are familiar with the auditing and reporting requirements of Office of Management and Budget *Uniform Administrative Requirements, Cost Principles, and Audit Requirements for Federal Grants (Uniform Grant Guidance)* as found in 2 CFR 200, and have reported and conducted our audit in accordance therewith.

We informed you of any changes in the above representations during the course of our work.

Sincerely,

Gregory S Adams, CPA

Gregory S Adams, CPA

2016 Turnaround Document

Instructions: In addition to the audit report, please complete this Turnaround Document only for each program audited for eligibility. Submit this form along with all required information to the Local Government Commission.

SPECIFIED PROGRAMS

Temporary Assistance for Needy Families (TANF)	93.558
Children's Health Insurance Program (CHIP)	93.767
Medical Assistance Program (Medicaid)	93.778

AUDITOR STATEMENT

Entity Audited:	CAMDEN COUNTY
Year Ended:	JUNE 30, 2016
Audit Organization:	THOMPSON, PRICE, SCOTT, ADAMS & CO, P.A.
Signature of Audit Organization:	<p>The information included on this form is based on information included in our workpapers and is based on our audit of the major federal program as applicable. We have not performed any auditing procedures since the date of the auditor's report and have not performed any additional auditing procedures in connection with the completion of this form.</p> <p>Signed: _____ <i>Gregory S. Adams</i> _____</p> <p>Title: _____ Manager _____</p>

Entity Audited:	CAMDEN COUNTY
Year Ended:	JUNE 30, 2016
Audit Organization:	THOMPSON, PRICE, SCOTT, ADAMS & CO, P.A.

Please include or attach any information for those programs audited for eligibility known at the time of submission that pertains to the following:

- 1) Indicators of possible management bias.
- 2) Additional related parties we should be aware of.
- 3) Significant risks of material noncompliance due to fraud or error, including your (the component auditor's) response to risk.
- 4) Noncompliance with laws or regulations that could give rise to a material misstatement in the SEFA.
- 5) Any other significant matters that you have communicated or expect to communicate to those charged with governance including fraud or suspected fraud involving program management, employees who have significant roles in internal control over compliance at the compliance requirement type level or others where the fraud resulted in a material misstatement or noncompliance.
- 6) Any other matters that you wish to bring to our attention.

Please include an explanation of the above items here or list attachments of any relevant documents.

NONE REPORTED.

March 2016

Entity Audited:	CAMDEN COUNTY
Year Ended:	JUNE 30, 2016
Audit Organization:	THOMPSON, PRICE, SCOTT, ADAMS & CO, P.A.

B. Temporary Assistance for Needy Families (TANF) (93.558)		Required Responses	
1	Indicate the program type at this entity in accordance with section 200.518 of <i>Uniform Grant Guidance</i> .	Type A <input type="checkbox"/>	Type B <input checked="" type="checkbox"/>
The program was audited due to (choose all that apply)			
A. Selection as a major program as a result of a risk assessment performed in accordance with section 200.518 of <i>Uniform Grant Guidance</i>		<input type="checkbox"/>	
B. Selection as a major program by the N.C. State Auditor's Office		<input type="checkbox"/>	
2.	The period covered for testing procedures performed (choose all that apply):		
A. Year-end only.		Control <input type="checkbox"/>	Compliance <input type="checkbox"/>
B. Interim with procedures extended to post-interim period.		Control <input type="checkbox"/>	Compliance <input type="checkbox"/>
C. Interim with alternate procedures applied to post-interim period. Explain the alternate procedures and rationale for these procedures:		Control <input type="checkbox"/>	Compliance <input type="checkbox"/>
3.	For the program audited, were there any audit findings <u>related to internal control deficiencies for the eligibility process</u> disclosed because of the audit?	Yes <input type="checkbox"/>	No <input type="checkbox"/>
If yes,	Please submit copies of the audit findings, including individual error documentation with this document. Note: Copies of only those audit findings <u>related to internal control deficiencies for the eligibility process</u> are required to be attached to this document.		
4.	For the program audited, provide the following regarding your sample and results of testing <u>internal controls for the eligibility process</u> :		
A. <u>Sample size</u> – The number of recipient files selected for audit and the total dollar value of the sample (if identifiable). Please explain the sample selection methodology if the sample size is less than 60:		Recipients	
		Dollar Value \$	
B. <u>Number of errors</u> – The number of recipient files noted to have one or more internal control deficiencies for the tested eligibility process.			
C. <u>Overall Conclusion & Final Assessment of Control Risk</u> – The overall conclusion including a summary of the final assessment of control risk (Maximum or Low) based on the audit procedures performed.			

March 2016

5.	For the program audited, were there any audit findings <u>related to eligibility noncompliance</u> disclosed because of the audit?	Yes <input type="checkbox"/>	No <input type="checkbox"/>
If yes,	Please submit copies of the audit findings, including individual error documentation with this document. Note: Copies of only those audit findings <u>related to eligibility noncompliance</u> are required to be attached to this document.		
6.	For the program audited, provide the following regarding your sample and results of testing <u>compliance of eligibility requirements</u> :		
A.	<u>Sample size</u> – The number of recipient files selected for audit and the total dollar value of the sample (if identifiable). Please explain the sample selection methodology if the sample size is less than 60:	Recipients Dollar Value \$	
B.	<u>Number of errors</u> – The number of recipient files noted to have one or more deficiencies in the tested compliance eligibility requirements.		
C.	<u>Questioned Costs</u> – Any amount associated with recipient files noted as ineligible or receiving incorrect benefit amounts.	\$	
D.	<u>Evaluation of Errors</u> – To provide perspective for judging the prevalence and consequences of the errors noted, please provide the projection of the identified errors to the overall population of recipients and the dollar value of the population. Please describe the methodology used for these projections.		
E.	<u>Additional Procedures (if necessary)</u> – If noncompliance is identified, explain the additional procedures performed to ensure the evaluation of errors are reasonable to assist in the classification of noncompliance. Please explain:		

Entity Audited:	CAMDEN COUNTY
Year Ended:	JUNE 30, 2016
Audit Organization:	THOMPSON, PRICE, SCOTT, ADAMS & CO, P.A.

D. Children's Health Insurance Program (CHIP) (93.767)		Required Responses	
1	Indicate the program type at this entity in accordance with section 200.518 of <u>Uniform Grant Guidance</u> .	Type A <input type="checkbox"/>	Type B <input checked="" type="checkbox"/>
	The program was audited due to (choose all that apply)		
	A. Selection as a major program as a result of a risk assessment performed in accordance with section 200.518 of <u>Uniform Grant Guidance</u>	<input type="checkbox"/>	
	B. Selection as a major program by the N.C. State Auditor's Office	<input type="checkbox"/>	
2.	The period covered for testing procedures performed (choose all that apply):		
	A. Year-end only.	Control <input type="checkbox"/>	Compliance <input type="checkbox"/>
	B. Interim with procedures extended to post-interim period.	Control <input type="checkbox"/>	Compliance <input type="checkbox"/>
	C. Interim with alternate procedures applied to post-interim period. Explain the alternate procedures and rationale for these procedures:	Control <input type="checkbox"/>	Compliance <input type="checkbox"/>
3.	For the program audited, were there any audit findings <u>related to internal control deficiencies for the eligibility process</u> disclosed because of the audit?	Yes <input type="checkbox"/>	No <input type="checkbox"/>
If yes,	Please submit copies of the audit findings, including individual error documentation with this document. Note: Copies of only those audit findings <u>related to internal control deficiencies for the eligibility process</u> are required to be attached to this document.		
4.	For the program audited, provide the following regarding your sample and results of testing <u>internal controls for the eligibility process</u> :		
	B. <u>Sample size</u> – The number of recipient files selected for audit and the total dollar value of the sample (if identifiable). Please explain the sample selection methodology if the sample size is less than 60:	Recipients	
		Dollar Value	
	B. <u>Number of errors</u> – The number of recipient files noted to have one or more internal control deficiencies for the tested eligibility process.		
	C. <u>Overall Conclusion & Final Assessment of Control Risk</u> – The overall conclusion including a summary of the final assessment of control risk (Maximum or Low) based on the audit procedures performed.		

March 2016

5.	For the program audited, were there any audit findings <u>related to eligibility noncompliance</u> disclosed because of the audit?	Yes <input type="checkbox"/>	No <input checked="" type="checkbox"/>		
	<p>If yes, Please submit copies of the audit findings, including individual error documentation with this document. Note: Copies of only those audit findings <u>related to eligibility noncompliance</u> are required to be attached to this document.</p>				
6.	For the program audited, provide the following regarding your sample and results of testing <u>compliance of eligibility requirements</u> :				
	<p>B. <u>Sample size</u> – The number of recipient files selected for audit and the total dollar value of the sample (if identifiable). Please explain the sample selection methodology if the sample size is less than 60: Total population was 2 or 100% tested.</p>	<table border="1"> <tr> <td data-bbox="1313 495 1317 596">Recipients</td> </tr> <tr> <td data-bbox="1313 596 1317 705">Dollar Value</td> </tr> </table>		Recipients	Dollar Value
Recipients					
Dollar Value					
	<p>B. <u>Number of errors</u> – The number of recipient files noted to have one or more deficiencies in the tested compliance eligibility requirements.</p>				
	<p>C. <u>Questioned Costs</u> – Any amount associated with recipient files noted as ineligible or receiving incorrect benefit amounts.</p>				
	<p>D. <u>Evaluation of Errors</u> – To provide perspective for judging the prevalence and consequences of the errors noted, please provide the projection of the identified errors to the overall population of recipients and the dollar value of the population. Please describe the methodology used for these projections.</p>				
	<p>E. <u>Additional Procedures (if necessary)</u> – If noncompliance is identified, explain the additional procedures performed to ensure the evaluation of errors are reasonable to assist in the classification of noncompliance. Please explain:</p>				

Entity Audited:	CAMDEN COUNTY
Year Ended:	JUNE 30, 2016
Audit Organization:	THOMPSON, PRICE, SCOTT, ADAMS & CO, P.A.

E. Medical Assistance Program (Medicaid) (93.778)		Required Responses	
1	Indicate the program type at this entity <u>in accordance with section 200.518 of Uniform Grant Guidance.</u>	Type A <input checked="" type="checkbox"/>	Type B <input type="checkbox"/>
	The program was audited due to (choose all that apply)		
	A. Selection as a major program as a result of a risk assessment performed in accordance with section 200.518 of <i>Uniform Grant Guidance</i>	<input checked="" type="checkbox"/>	
	B. Selection as a major program by the N.C. State Auditor's Office	<input type="checkbox"/>	
2.	The period covered for testing procedures performed (choose all that apply):		
	A. Year-end only.	Control <input checked="" type="checkbox"/>	Compliance <input checked="" type="checkbox"/>
	B. Interim with procedures extended to post-interim period.	Control <input type="checkbox"/>	Compliance <input type="checkbox"/>
	C. Interim with alternate procedures applied to post-interim period. Explain the alternate procedures and rationale for these procedures:	Control <input type="checkbox"/>	Compliance <input type="checkbox"/>
3.	For the program audited, were there any audit findings <u>related to internal control deficiencies for the eligibility process</u> disclosed because of the audit?	Yes <input type="checkbox"/>	No <input checked="" type="checkbox"/>
If yes,	Please submit copies of the audit findings, including individual error documentation with this document. Note: Copies of only those audit findings <u>related to internal control deficiencies for the eligibility process</u> are required to be attached to this document.		
4.	For the program audited, provide the following regarding your sample and results of testing <u>internal controls for the eligibility process</u> :		
	C. <u>Sample size</u> – The number of recipient files selected for audit and the total dollar value of the sample (if identifiable). Please explain the sample selection methodology if the sample size is less than 60:	Recipients 60	Dollar Value
	B. <u>Number of errors</u> – The number of recipient files noted to have one or more internal control deficiencies for the tested eligibility process.	0	

March 2016

C. Overall Conclusion & Final Assessment of Control Risk – The overall conclusion including a summary of the final assessment of control risk (Maximum or Low) based on the audit procedures performed.

Based upon our procedures and the results therein, we conclude that our initial assessment of control risk (low) for the eligibility process remains unchanged. We tested controls to support our low control risk assessment for the components of internal control over the eligibility compliance requirement, as well as the other direct and indirect compliance requirements for the major program. Controls are properly designed, implemented and operating effectively, maintaining a low assessed level of control risk of noncompliance.

5.	For the program audited, were there any audit findings <u>related to eligibility noncompliance</u> disclosed because of the audit?	Yes <input type="checkbox"/>	No <input checked="" type="checkbox"/>
If yes,	Please submit copies of the audit findings, including individual error documentation with this document. Note: Copies of only those audit findings <u>related to eligibility noncompliance</u> are required to be attached to this document.		
6.	For the program audited, provide the following regarding your sample and results of testing <u>compliance of eligibility requirements</u> :		
C.	<u>Sample size</u> – The number of recipient files selected for audit and the total dollar value of the sample (if identifiable). Please explain the sample selection methodology if the sample size is less than 60:	Recipients 60	Dollar Value
B.	<u>Number of errors</u> – The number of recipient files noted to have one or more deficiencies in the tested compliance eligibility requirements.	0	
C.	<u>Questioned Costs</u> – Any amount associated with recipient files noted as ineligible or receiving incorrect benefit amounts.	\$0.00	
D.	<u>Evaluation of Errors</u> – To provide perspective for judging the prevalence and consequences of the errors noted, please provide the projection of the identified errors to the overall population of recipients and the dollar value of the population. Please describe the methodology used for these projections.		
E.	<u>Additional Procedures (if necessary)</u> – If noncompliance is identified, explain the additional procedures performed to ensure the evaluation of errors are reasonable to assist in the classification of noncompliance. Please explain:		

Camden County, NC LIVE

BALANCE SHEET FOR 2016 13

FUND: 0001 CENTRAL DEPOSITORY		NET CHANGE FOR PERIOD	ACCOUNT BALANCE
ASSETS			
01	101001	7,335.54	13,283,692.62
01	101002	-7,335.54	8,097.25
01	101006	.00	652,393.56
01	101007	.00	2,615.97
01	101008	.00	1,537.94
	TOTAL ASSETS	.00	15,948,337.34
LIABILITIES			
01	201010	3,292.82	-6,524,184.98
01	201012	.00	-61,781.93
01	201013	.00	-11,362.90
01	201014	.00	-6,529.85
01	201015	4,203.06	-94,340.33
01	201023	.00	-693,479.59
01	201029	.00	-1,209,253.14
01	201030	69.12	-581,065.80
01	201032	4,968.04	-82,307.24
01	201036	.00	-60,448.98
01	201037	.00	-461.05
01	201038	.00	-22,170.89
01	201039	.00	-5,587.29
01	201040	-2,163.20	-233,670.26
01	201041	-1,291.08	-377,639.74
01	201050	.00	-13,811.88
01	201051	.00	-8,880.48
01	201052	.00	-271,713.52
01	201053	.00	-233,875.37
01	201055	.00	-175,313.31
01	201056	.00	-1,537.94
01	201060	-9,078.76	-7,620.63
01	201065	.00	-80,641.66
01	201070	.00	-359,890.05
01	201071	.00	-2,580,996.65
01	201075	.00	-249,771.88
	TOTAL LIABILITIES	.00	13,948,337.34
	TOTAL LIABILITIES + FUND BALANCE	.00	15,948,337.34

** END OF REPORT - Generated by Stephanie Humphries **



Board of Commissioners
AGENDA ITEM SUMMARY SHEET

New Business

Item Number: 6.B
Meeting Date: March 06, 2017

Submitted By: Lisa Anderson, Tax Administrator
Taxes
Prepared by: Lisa Anderson

Item Title **January 2017 Monthly Report**

Attachments: Monthly Tax Report - Jan 2017 (PDF)

Summary: January 2017 Monthly Report

Recommendation: Review and approve

**MONTHLY REPORT OF THE TAX ADMINISTRATOR TO THE
CAMDEN COUNTY BOARD OF COMMISSIONERS**

OUTSTANDING TAX DELINQUENCIES BY YEAR

<u>YEAR</u>	<u>REAL PROPERTY</u>	<u>PERSONAL PROPERTY</u>
2016	428,534.49	13,274.19
2015	85,501.83	4,139.05
2014	40,360.49	2,913.55
2013	17,984.22	6,586.98
2012	12,478.76	9,150.40
2011	8,771.81	7,431.62
2010	6,581.69	5,116.63
2009	4,647.24	4,795.41
2008	3,971.28	5,231.68
2007	4,010.88	6,951.40

TOTAL REAL PROPERTY TAX UNCOLLECTED	612,842.69
TOTAL PERSONAL PROPERTY UNCOLLECTED	65,590.91
TEN YEAR PERCENTAGE COLLECTION RATE	98.99%
COLLECTION FOR 2017 vs. 2016	1,680,022.16 vs. 449,369.20

LAST 3 YEARS PERCENTAGE COLLECTION RATE

2016	93.39%
2015	98.65%
2014	99.36%

THIRTY LARGEST UNPAID ACCOUNTS

SEE ATTACHMENT "A"

THIRTY OLDEST UNPAID ACCOUNTS

SEE ATTACHMENT "B"

EFFORTS AT COLLECTION IN THE LAST 30 DAYS

ENDING January 2017

BY TAX ADMINISTRATOR

<u>513</u>	NUMBER DELINQUENCY NOTICES SENT
<u>22</u>	FOLLOWUP REQUESTS FOR PAYMENT SENT
<u>3</u>	NUMBER OF WAGE GARNISHMENTS ISSUED
<u>14</u>	NUMBER OF BANK GARNISHMENTS ISSUED
<u>13</u>	NUMBER OF PERSONAL PHONE CALLS MADE BY TAX ADMINISTRATOR TO DELINQUENT TAXPAYER
<u>0</u>	NUMBER OF PERSONAL VISITS CONDUCTED (COUNTY OFFICES)
<u>0</u>	PAYMENT AGREEMENTS PREPARED UNDER AUTHORITY OF TAX ADMINISTRATOR
<u>0</u>	NUMBER OF PAYMENT AGREEMENTS RECOMMENDED TO COUNTY ATTORNEY
<u>0</u>	NUMBER OF CASES TURNED OVER TO COUNTY ATTORNEY FOR COLLECTION (I.D. AND STATUS)
<u>1</u>	REQUEST FOR EXECUTION FILES WITH CLERK OF COURTS
<u>1</u>	NUMBER OF JUDGMENTS FILED

Roll	Parcel Number	Unpaid Amount	YrsDlq	Taxpayer Name	City	Property Address
R	03-8943-04-74-3506.0000	16,419.25	3	ELLIOTT & DONNA JACOBS	SHILOH	117 SUNSET AVE
R	01-7989-00-01-1714.0000	10,653.18	3	CHARLES MILLER HEIRS	SOUTH MILLS	HORSESHOE RD
R	02-8934-01-17-4778.0000	10,563.66	1	LARRY G. LAMB SR	CAMDEN	152 158 US W
R	03-8971-00-12-0477.0000	8,062.31	2	GILBERT WAYNE OVERTON &	SHILOH	187 THOMAS POINT RD
R	02-8944-00-87-7021.0000	7,830.77	1	MARK M. BRIGMAN SR & LISA L.	CAMDEN	175 MCKIMMEY RD
R	01-8907-00-65-3412.0000	7,187.73	1	WAVERLY MEIGGS SAWYER	SOUTH MILLS	866 343 HWY N
R	03-8953-04-81-9832.0000	6,594.63	5	MAIDIA S. CECIL HEIRS	SHILOH	113 TROTMAN RD
R	03-8899-00-45-2682.0000	6,243.84	3	SEAMARK INC.	SHILOH	HOLLY RD
R	03-8971-00-23-2253.0000	5,025.80	2	ABODE OF CAMDEN, INC.	SHILOH	187 C THOMAS POINT RD
R	01-7081-00-81-4060.0000	4,991.16	1	CRAIG S. CAREY	SOUTH MILLS	201 SHARON CHURCH RD
R	02-8934-01-06-3185.0000	4,884.14	1	WAVERLY M SAWYER	CAMDEN	117 HAVENWOOD DR
R	01-7998-01-08-8621.0000	4,703.21	4	WILLIE L. TURNER ETAL	SOUTH MILLS	1289 343 HWY N
R	02-8935-04-63-0820.0000	4,560.91	1	BELCROSS PROPERTIES, LLC	CAMDEN	197 158 US E
R	03-8973-00-19-2109.0000	4,340.07	2	WANDA ADAMS	SHILOH	765 SANDY HOOK RD
R	01-7998-01-08-6797.0000	4,230.70	2	EDWARD E. HARRIS JR.	SOUTH MILLS	1295 343 HWY N
R	02-8935-02-66-7093.0000	4,108.38	3	B. F. ETHERIDGE HEIRS	CAMDEN	158 US E
R	02-8945-00-41-2060.0000	4,089.49	1	LASELLE ETHERIDGE SR.	CAMDEN	168 BUSHELL RD
R	02-8934-01-18-6001.0000	4,046.28	1	LINDA SUE LAMB HINTON	CAMDEN	150 158 US W
R	01-7979-00-61-7358.0000	3,887.67	1	BERT LLC	SOUTH MILLS	HORSESHOE RD
R	03-8965-00-13-1025.0000	3,832.20	3	SHARON EVANS MUNDEN	SHILOH	556 TROTMAN RD
R	02-8945-00-54-1099.0000	3,547.63	2	GERTIE LEE & JONOLA T ROUNTREE	CAMDEN	263 BELCROSS RD
R	03-8953-03-12-6266.0000	3,493.63	1	R.VERNON BRAY, JR.	SHILOH	120 LAUREN LN
R	01-7081-00-52-7312.0000	3,345.38	3	WILLIAM K. COLONNA	SOUTH MILLS	256 CULPEPPER RD
R	03-8973-00-22-3033.0000	3,280.35	1	TAYLOR LEIGH PROPERTIES LLC	SHILOH	RICKS WAY
R	02-8944-00-31-2148.0000	3,261.75	3	CARL HARRINGTON	CAMDEN	150 SAND HILLS RD
R	02-8937-00-50-8036.0000	3,236.69	2	CLEVELAND WALSTON LE	CAMDEN	187 HERMAN ARNOLD RD
R	03-8964-00-40-9957.0000	3,029.92	3	LASALLE SEARS HEIRS	SHILOH	291 BARTLETT RD
R	02-8923-00-19-3774.0010	3,024.06	3	WILLIAM CONOVER	CAMDEN	431 158 US W
R	01-7999-00-46-1105.0000	2,900.97	1	LINDA EASON COLSON	SOUTH MILLS	176 PUDDING RIDGE RD
R	03-8972-00-44-8500.0000	2,897.97	2	ABODE OF CAMDEN INC.	SHILOH	343 HWY S

02/27/17 13:05:32

Delinquencies Top-30 Unpaid

1 Road
Attachment "A"

Attachment: Monthly Tax Report - Jan 2017 (1584 : Monthly Tax Report - January 2017)

Roll	Parcel Number	YrsDlq	Unpaid Amount	Taxpayer Name	City	Property Address
R	01-7989-00-01-1714.0000	10	10,653.18	CHARLES MILLER HEIRS	SOUTH MILLS	HORSESHOE RD
R	03-8899-00-45-2682.0000	10	6,243.84	SEAMARK INC.	SHILOH	HOLLY RD
R	03-8943-04-93-8214.0000	10	2,451.03	L. P. JORDAN HEIRS	SHILOH	108 CAMDEN AVE
R	01-7988-00-91-0179.0001	10	2,303.62	THOMAS L. BROTHERS HEIRS	SOUTH MILLS	
R	03-8952-00-95-8737.0000	10	2,137.98	AUDREY TILLET	SHILOH	171 NECK RD
R	01-7999-00-32-3510.0000	10	1,968.33	LEAH BARCO	SOUTH MILLS	195 BUNKER HILL RD
R	01-7999-00-12-8596.0000	10	1,897.48	MOSES MITCHELL HEIRS	SOUTH MILLS	165 BUNKER HILL RD
R	02-8935-01-19-4055.0000	10	1,557.27	ANDERSON CARTWRIGHT SR.	CAMDEN	271 SLEEPY HOLLOW RD
R	01-7989-04-60-1954.0000	10	1,223.39	CHRISTINE RIDDICK	SOUTH MILLS	105 BLOODFIELD RD
R	03-8962-00-50-0273.0000	10	969.61	DAISEY WILLIAMS BURNHAM	SHILOH	RAYMONS CREEK RD
R	01-7090-00-60-5052.0000	10	832.10	JOE GRIFFIN HEIRS	SOUTH MILLS	117 GRIFFIN RD
R	02-8955-00-13-7846.0000	10	669.66	MARIE MERCER	CAMDEN	IVY NECK RD
R	02-8936-00-24-7426.0000	10	633.09	BERNICE PUGH	CAMDEN	113 BOURBON ST
R	01-7998-00-57-2800.1000	10	427.45	TINA RENEE LEARY	SOUTH MILLS	111 LINTON RD
R	01-7090-00-95-5262.0000	10	271.56	JOHN F. SAWYER HEIRS	SOUTH MILLS	OLD SWAMP RD
R	03-8980-00-61-1968.0000	10	265.74	WILLIAMSBURG VACATION	SHILOH	CAMDEN POINT RD
R	03-9809-00-45-1097.0000	10	229.30	MICHAEL OBER	SHILOH	CENTERPOINT RD
R	03-8899-00-37-0046.0000	10	179.37	ELIZABETH LONG	SHILOH	HIBISCUS
R	03-9809-00-17-2462.0000	10	160.77	TODD ALLEN RIGGS	SHILOH	LITTLE CREEK RD
R	01-7989-04-60-1568.0000	9	1,116.09	EMMA BRITE HEIRS	SOUTH MILLS	116 BLOODFIELD RD
R	03-8953-04-81-9832.0000	8	6,594.63	MAIDIA S. CECIL HEIRS	SHILOH	113 TROTMAN RD
R	02-8945-00-41-2060.0000	8	4,089.49	LASELLE ETHERIDGE SR.	CAMDEN	168 BUSHELL RD
R	01-7080-00-62-1977.0000	8	2,489.37	SANDERS CROSSING OF CAMDEN CO	SOUTH MILLS	117 OTTERS PL
R	03-9809-00-24-6322.0000	8	545.38	DAVID B. KIRBY	SHILOH	499 SAILBOAT RD
R	01-7998-01-08-8621.0000	7	4,703.21	WILLIE L. TURNER ETAL	SOUTH MILLS	1289 343 HWY N
R	01-7998-01-08-6797.0000	7	4,230.70	EDWARD E. HARRIS JR.	SOUTH MILLS	1295 343 HWY N
R	03-8964-00-40-9957.0000	7	3,029.92	LASALLE SEARS HEIRS	SHILOH	291 BARTLETT RD
R	03-8980-00-84-0931.0000	7	189.06	CARL TEUSCHER	SHILOH	218 BROAD CREEK RD
R	01-7989-04-90-6715.0000	6	2,593.62	ANDREW FEREBEE HEIRS	SOUTH MILLS	1334 343 HWY N
R	03-8962-00-04-9097.0000	6	1,854.98	CECIL BARNARD HEIRS	SHILOH	NECK RD

02/27/17 13:05:33

Delinquencies Top-30 Oldest

1 Pearl
Attachment "B"

Attachment: Monthly Tax Report - Jan 2017 (1584 : Monthly Tax Report - January 2017)

Roll	Parcel Number	Unpaid Amount	YrsDlq	Taxpayer Name	City	Property Address
P	0001623	3,885.70	1	ATLANTIC COASTAL CLEARING	CAMDEN	
P	0001709	1,960.50	8	JOHN MATTHEW CARTER	CAMDEN	158 HWY
P	0000738	904.69	6	LESLIE ETHERIDGE JR	CAMDEN	431 158 US W
P	0001538	882.79	9	JEFFREY EDWIN DAVIS	HERTFORD	MIC MAC TRAIL
P	0001046	844.03	9	THIEN VAN NGUYEN	SHILOH	133 EDGEWATER DR
P	0000659	835.00	1	RICKY'S WELDING, INC.	SHILOH	864 SANDY HOOK RD
P	0001883	778.89	6	DUNG LE TRAN	SHILOH	255 SAILBOAT ROAD
P	0001072	730.04	9	PAM BUNDY	SHILOH	105 AARON DR
P	0001827	652.02	3	KAREN BUNDY	CAMDEN	431 158 US W
P	0001104	614.60	1	MICHAEL & MICHELLE STONE	CAMDEN	107 RIDGE ROAD
P	0002194	538.90	2	MORGAN ROBERSON	SHILOH	849 SANDY HOOK RD S
P	0002185	448.60	1	DIRECT TV,LLC	CAMDEN	
P	0000543	420.48	2	TRACK 1 OF CAMDEN	CAMDEN	143 158 US W
P	0001230	411.11	5	JAMES NYE	SOUTH MILLS	101 ROBIN CT W
P	0001694	344.85	5	THOMAS B.THOMAS HEIRS	CAMDEN	150 158 HWY W
P	0001681	313.74	5	STEVE WILLIAMS	CAMDEN	150 158 HWY W
P	0000297	309.81	2	ADAM D. & TRACY J.W. JONES	SHAWBORO	114 GARRINGTON ISLAND
P	0001476	306.68	1	MIKE TAYLOR	ELIZABETH CITY	CAMDEN CAUSEWAY
P	0001010	304.99	4	RAYBURN BURGESS	SHILOH	116 EDGEWATER DR
P	0001546	303.28	2	GEORGE ROWLAND	CAMDEN	431 158 US W
P	0000905	291.52	2	KEVIN & STACY ANDERSON	SHILOH	111 AARON DR
P	0001106	280.28	10	JAMI ELIZABETH VANHORN	SOUTH MILLS	617 MAIN ST
P	0001250	277.93	2	MICHELE LEE TAYLOR-DUKE	SOUTH MILLS	108 BINGHAM RD
P	0002565	277.38	1	DUANE EDWARD DUNIVAN	SOUTH MILLS	115 WAYLAND CT
P	0001976	275.54	4	ANA ALICIA MARTINEZ LOPEZ	SHILOH	110 AARON DR
P	0001703	270.00	3	VAN ZANDER	MOYOCK	812 TULLS CREEK RD
P	0000688	269.10	1	WAVERLY M SAWYER	CAMDEN	HAVENWOOD DR
P	0001693	261.90	8	ALLIANCE NISSAN	CAMDEN	158 HWY W
P	0001853	249.66	3	JOHN FRANCIS HICKS	CAMDEN	138 COUNTRY CLUB RD
P	0001952	238.91	5	SANDY BOTTOM MATERIALS, INC	SOUTH MILLS	319 PONDEROSA RD

02/27/17 13:05:51

Delinquencies Top-30 Unpaid

Attachment "A"
Personal

Attachment: Monthly Tax Report - Jan 2017 (1584 : Monthly Tax Report - January 2017)

Roll	Parcel Number	YrsDlq	Unpaid Amount	Taxpayer Name	City	Property Address
P	0000738	10	904.69	LESLIE ETHERIDGE JR	CAMDEN	
P	0001046	10	844.03	THIEN VAN NGUYEN	SHILOH	133 EDGEWATER DR
P	0001072	10	730.04	PAM BUNDY	SHILOH	105 AARON DR
P	0001106	10	280.28	JAMI ELIZABETH VANHORN	SOUTH MILLS	617 MAIN ST
P	0000248	10	219.71	ROBERT H. OWENS	CAMDEN	363 # 15
P	0001538	9	882.79	JEFFREY EDWIN DAVIS	HERTFORD	MIC MAC TRAIL
P	0001540	9	120.95	DAVID LUKE	ELIZABETH CITY	CAMDEN CAUSEWAY
P	0001709	8	1,960.50	JOHN MATTHEW CARTER	CAMDEN	158 HWY
P	0001693	8	261.90	ALLIANCE NISSAN	CAMDEN	158 HWY W
P	0001673	8	177.05	THOMAS PHILLIP WINSLOW	CAMDEN	158 HWY W
P	0000316	8	115.56	JAMES P. JONES	CAMDEN	142 SANDHILLS RD
P	0001827	7	652.02	KAREN BUNDY	CAMDEN	431 158 US W
P	0001883	6	778.89	DUNG LE TRAN	SHILOH	255 SAILBOAT ROAD
P	0001697	6	144.00	RANDY BRICKHOUSE	CAMDEN	150 158 HWY W
P	0001722	6	140.55	JANET LEARY	SOUTH MILLS	LINTON ROAD
P	0001230	5	411.11	JAMES NYE	SOUTH MILLS	101 ROBIN CT W
P	0001694	5	344.85	THOMAS B.THOMAS HEIRS	CAMDEN	150 158 HWY W
P	0001681	5	313.74	STEVE WILLIAMS	CAMDEN	150 158 HWY W
P	0001250	5	277.93	MICHELE LEE TAYLOR-DUKE	SOUTH MILLS	108 BINGHAM RD
P	0001952	5	238.91	SANDY BOTTOM MATERIALS, INC	SOUTH MILLS	319 PONDEROSA RD
P	0000865	5	176.13	DIAN BURNHAM COHENS	SHILOH	133 ALDER BRANCH RD
P	0000770	5	159.00	MARSHA GAIL BOGUES	CAMDEN	276 BELCROSS RD
P	0001740	5	107.00	JASON & KEVIN WORDEN	SOUTH MILLS	STILES LANE
P	0002194	4	538.90	MORGAN ROBERSON	SHILOH	849 SANDY HOOK RD S
P	0001010	4	304.99	RAYBURN BURGESS	SHILOH	116 EDGEWATER DR
P	0001976	4	275.54	ANA ALICIA MARTINEZ LOPEZ	SHILOH	110 AARON DR
P	0002058	4	151.40	WILLIAM GILMER BURK	CAMDEN	493 LAMBS RD
P	0001104	3	614.60	MICHAEL & MICHELLE STONE	CAMDEN	107 RIDGE ROAD
P	0000543	3	420.48	TRACK 1 OF CAMDEN	CAMDEN	143 158 US W
P	0000905	3	291.52	KEVIN & STACY ANDERSON	SHILOH	111 AARON DR

02/27/17 13:05:52

Delinquencies Top-30 Oldest

1
Person

Attachment "B"

Attachment: Monthly Tax Report - Jan 2017 (1584 : Monthly Tax Report - January 2017)



CAMDENCOUNTY

new energy. new vision.

Board of Commissioners AGENDA ITEM SUMMARY SHEET

New Business

Item Number: 6.C
Meeting Date: March 06, 2017

Submitted By: Angela Wooten, Clerk to the Board
Administration
Prepared by: Angela Wooten

Item Title **Trillium Health Resources - Annual Report & Resolution No. 2017-02-03**

Attachments: Camden County Annual Update and State Funding
Presentation (PPTM)
Microsoft Word - Budget Talking Points.docx (PDF)
Resolution No. 2017-02-03 (PDF)

Presentation by: **Bland Baker**
Norther Regional Director
Trillium Health Resources

Summary:

Trillium Health Resources Taking Care of Eastern NC



Transforming Lives



Trillium Update

- Trillium Health Resources marked its one year anniversary on July 1, 2016 following the consolidation of East Carolina Behavioral Health and Coastal Care.
- Trillium continues to invest in innovation to meet the needs of individuals we serve and remains focused on delivering the right services, in the right amount, at the right time.
- We manage the behavioral health and I/DD services for the Medicaid and the indigent population.

Annual Gaps and Needs Process

Data Reviewed:

- Demographic and health information
- National prevalence data for MH/DD/SA issue
- Survey participants and stakeholders
- Complaints and grievances, Registry of Unmet Needs
- Geo-mapping data

Process:

- Online Survey
- On-site work with CFAC's and Board
- Compile and analyze data
- Develop strategies to address gaps and needs
- Present action plan to board for adoption

Reinvestment plan for Eastern NC

The results of the Gaps and Needs Assessment drives Trillium's Reinvestment Plan.

Trillium's Board for Directors in 2016 approved a Reinvestment plan that addressed major gaps and needs in eastern NC Mental Health Developmental Disabilities and Substance Abuse services system.

The plan is designed to improve care and quality of life for people with Mental Health, Substance Use Disorders or Intellectual and Developmental Disabilities.

Trillium's Reinvestment Plan

- Some of those projects include:
 1. Healing Place
Facility for individuals who struggle with addiction
 2. Oxford House
20 sober-living homes
 3. Accessible playgrounds
30 playgrounds

Trillium's Reinvestment Plan Continued

4. Evidenced-Based Services and Supports

Child First

Mental Health First Aid Training

5. Access Point Kiosks

Mental Health and Substance Use Screenings

Current Statistics for 2015

- Served approximately 50,000 people
- Total Cost = \$340,242,416.01
- Over 400 Providers

Service Array in Camden County

- Out-patient /Medication Management
- Psychiatric Services
- Substance Abuse Individual Treatment/Group
- ChildFirst
- Residential
- Mobile Crisis Management
- Innovations
- IDD Day Programs
- Intensive In-home
- Multisystemic therapy

Statistics for Camden County

- Total Consumers served - 246
- Mental Health - 200
- Substance Use - 56
- I/DD - 35

Total Dollars - \$1,884,065

Trillium's Funding for Services

- Medicaid Funding 1915(b) and (b)(3) waivers
- Innovations Waiver
- State Funding
- County Funding
- Fund Balance or Savings

State Funding

- Trillium historically received approximately \$41 million in state single stream funding to be used for services
- Some of this funding is a match to federal block grant funding and required to be used for Mental Health and Substance Use disorders
- Some of this funding is required to be paid for legacy programs
- Approximately 20 million dollars annually has historically been used to fund services that Medicaid does not cover. This includes over 200 people living in group homes and many others who receive supports through day programs, Supported Employment, respite, developmental therapy etc..

What happened in the 2015-2016 budget process?

- Over the past two fiscal years, the General Assembly has reduced State funding for mental health (MH), substance use disorder (SU), and intellectual and other developmental disability services (I/DD) by \$263.7 million and required those reductions to be filled using LME/MCO savings.

What happened in the 2015-2016 budget process?

- The current formula the NCGA uses, which tags the reduction to cash balances as of June 30, 2015, is very unfair to Trillium. We have implemented our reinvestment plan, which has resulted in our cash balance decreasing relative to the other LME/MCOs.
 - At June 30, 2015, the Trillium cash balance was 15.11% of the statewide total, so we received 15.11% of the \$110.8 million reduction for SFY 2015-2016.
 - At June 30, 2016, the Trillium cash balance was only 13.13% of the statewide total, but since the formula was not adjusted, we still received 15.11% of the \$152.8 million reduction. The resulted in an additional reduction of \$3 million to Trillium.
 - As of October 31, 2016 (the latest statewide numbers available), Trillium's cash balance was down to 11.61% of the statewide total, meaning our share of the 2016-2017 reduction is actually \$5.3 million more this year than our "fair share."

Fund Balance/Savings Picture today

- In June, 2014 Trillium had approximately \$10.3 million in state fund balance.
- By June, 2016 that state fund balance was completely exhausted
- Trillium has had to use unrestricted Medicaid fund balance to assure services have continued
- If all continues as is by July 1, 2017 that unrestricted Medicaid fund balance may be less than \$3 million.

What is the potential impact going to be June 2017?

- Many people may lose services and be dependent on families to care for them or end up in more costly levels of care like nursing homes, hospitals or institutions.
- **236** people with Mental Illness and Developmental Disabilities are at risk of losing their placement in group homes and having to move to higher levels of care because family is often not able to take care of their complex needs.
- **254** children with IDD may receive no services of any kind not even respite so the caregivers can recharge
- **319** Adults with IDD served by local day programs that have been part of communities for over 25 years may end up closing and those adults with IDD will be stuck at home
- Hundreds of jobs may be lost in every county some of which are already struggling communities with high unemployment rates.
- Some people's health and safety may be endangered without the support or supervision that is needed

What is Trillium doing?

- Advocating that the money be permanently restored to the budget for MHDDSA services
- If the General Assembly doesn't restore the funding, we ask that they acknowledge the innovations in the communities made by Trillium reinvestment and the improvement in the overall quality of life for people and ask that the NCGA readjust the formula is used to calculate what Trillium has to pay from savings since Trillium's saving has been impacted disproportionately in comparison to the other LMEMCOs.

What can you do?

- Call/Write/Email/Use Social media to get your legislators attention.
- As local elected county commissioners you can work with NCCCA requesting they advocate with the NCGA and reach out individually to NCGA.
- Pass the resolution presented today to show your support for people with mental health, substance use and intellectual/developmental disabilities.



Mental Health Funding Talking Points

Over the past two fiscal years, the General Assembly has reduced State funding for mental health (MH), substance use disorder (SU), and intellectual and other developmental disability services (I/DD) by \$263.7 million and required those reductions to be filled using LME/MCO savings. This cannot continue.

Background

- NC is the 11th fastest growing State in the Nation and the 9th largest in population overall. Those increasing numbers also mean more people with mental illness health, substance use disorder, and I/DD are moving to our State, further increasing the need for services funding.
- Despite this growth, NC is one of only 3 States to have reduced funding for MHDDSA services for the past 4 years in a row. The other two states that have reduced funding have not experienced similar population growth.
- Inadequate funding results in cost-shifts to other systems. People with unaddressed mental health or addiction needs don't go away; they wind up in jail, hospital emergency departments and/or homeless shelters.
- There are nearly 11,000 people in NC who are on the waiting list for Medicaid-funded I/DD services. Many of them are dependent upon limited State funding to avoid more costly institutionalization.

But, don't the LME/MCOs have money?

- The LME/MCOs do have some one time funds, but their Boards have developed and are implementing specific plans to use those funds to meet pressing community needs. They are also at-risk to provide all medically necessary Medicaid services regardless of how much they cost and so must have money in the bank to provide for cash flow and cover unexpected cost over-runs.
 - When the General Assembly mandated statewide implementation of the 1915(b)(c) Medicaid Waiver for behavioral health and intellectual and developmental disabilities, it was expected that the LME/MCOs would achieve savings by managing a previously unmanaged system. The goal was that those savings would be available to reinvest in services to counteract years of stagnant or dwindling budgets.
 - LME/MCOs are subject the requirements of the Local Government Commission in the Office of the State Treasurer. Among those requirements is that they must maintain at least 30 days of cash on hand. This is just prudent business. For the 7 LME/MCOs 30 days of cash is \$240.7 million dollars.
- LME/MCOs are entities of local government – there is no profit motive or stockholders expecting a return on investment. All savings are available for reinvestment in communities. They are accountable to the counties and communities they serve; their Boards of Directors are local elected officials and residents.

- The savings the LME/MCOs have generated are one-time funds; by definition one-time, non-recurring funds cannot meet ongoing service needs.
- The payments that LME/MCO receive from Medicaid continue to be reduced as costs are reduced, which is to be expected, so the savings being generated currently are far less than they were at start-up.

Impact on Trillium

- Trillium will have spent nearly \$40 million dollars of its own savings replacing state funding reductions mandated by the General Assembly by June 30, 2017.
- If reductions continue, Trillium will be forced to reduce state services and curtail reinvestment projects.
 - State service reductions may have to include:
 - § Reducing State-funded group homes and other residential services for adults with mental illness and I/DD
 - § Reducing State-funded day programming for adults with I/DD
 - § Limiting most non-Medicaid consumers to just outpatient therapy services only instead of more effective evidence-based practices.
 - Reinvestment projects that may have to be eliminated or dramatically scaled back:
 - § Replication of The Healing Place, a very successful long-term substance use recovery program, in two locations (Greenville and Wilmington). Our area has been very hard hit by the opioid epidemic and this program would help to address that crisis.
 - § Further expansion of inclusive programs for children and adults with I/DD.
 - § Creation of additional Oxford Houses to provide a sober-living environment for people recovering from addictions like heroin and alcohol.
 - § Efforts to increase the quality of services received by consumers by increasing the competency of the staff who serve them through additional training and targeted rate increases.
 - § Eliminating or drastically reducing funding available for one-time purchases, such as wheelchairs, ramps, feeding pumps, etc., which allow people to continue to live at home and avoid institutionalization.
- Finally, if any further reductions must be made, the formula mandated by the General Assembly on how those reductions are allocated among the LME/MCOs must be changed. The current formula, which tags the reduction to cash balances as of June 30, 2015, is very unfair to Trillium. We have implemented our reinvestment plan, which has resulted in our cash balance decreasing relative to the other LME/MCOs.
 - At June 30, 2015, the Trillium cash balance was 15.11% of the statewide total, so we received 15.11% of the \$110.8 million reduction for SFY 2015-2016.
 - At June 30, 2016, the Trillium cash balance was only 13.13% of the statewide total, but since the formula was not adjusted, we still received 15.11% of the \$152.8 million reduction. The resulted in an additional reduction of \$3 million to Trillium.
 - As of October 31, 2016 (the latest statewide numbers available), Trillium’s cash balance was down to 11.61% of the statewide total, meaning our share of the 2016-2017 reduction is actually \$5.3 million more this year than our “fair share.”

BOARD OF COMMISSIONERS

CLAYTON D. RIGGS
Chairman

G. TOM WHITE
Vice Chairman

GARRY W. MEIGGS
RANDY KRAINIAK
ROSS B. MUNRO



CAMDENCOUNTY
new energy. new vision.

MICHAEL L. BRILLHART
County Manager

ANGELA L. WOOTEN
Clerk to the Board

JOHN S. MORRISON
County Attorney

RESOLUTION No. 2017-02-03

Resolution of Support for Adequate Funding to meet the Mental Health, Intellectual and Developmental Disabilities and Substance Use Disorder service needs for Citizens of Camden County

WHEREAS, Camden County knows that citizens dealing with mental illness and substance use disorders can achieve recovery with the appropriate services and supports and that citizens with intellectual and developmental disabilities can live productive lives in our communities with similar services and supports; and

WHEREAS, the funding needed for such services and supports is increasing due to North Carolina's increasing population and the opioid epidemic in our State; and

WHEREAS, Camden County is a member of Trillium Health Resources, a twenty-four county LME/MCO serving eastern North Carolina; and

WHEREAS, in accordance with the intent of the NC General Assembly and the NC Department of Health and Human Services, the Board of Trillium Health Resources has developed and is implementing a robust reinvestment plan to use savings that is benefiting the citizens of Camden County with such enhancements as accessible playgrounds, Access Point Kiosks, and new evidenced-based services; and

WHEREAS, the North Carolina General Assembly has made significant budget reductions in State funding for the past two years; and

WHEREAS, the formula used to allocate the reduction statewide in the current fiscal year was based on 2015 information which has resulted in a disproportionate reduction to Trillium Health Resources; and

WHEREAS, these budget reductions can no longer be absorbed by Trillium Health Resources without jeopardizing services to Camden County citizens, negatively impacting the lives of people in need of service as well as potentially impacting the local economy through job loss;

NOW, THEREFORE BE IT RESOLVED that we, the Camden County Board of Commissioners do hereby request that the North Carolina General Assembly:

- *Maintain full State funding for mental health, developmental disabilities and substance abuse services without further reductions; and*
- *Allow Trillium Health Resources to continue to use its savings to reinvest in enhanced services in our communities rather than having to use that funding to replace State budget reductions; and*
- *Modify the formula by which any future reductions in funding are allocated, if such reductions must be made, to ensure the reduction is fairly distributed statewide.*

ADOPTED this 20th day of February, 2017.

*Chairman Clayton D. Riggs
Camden County Board of Commissioners*

ATTEST: _____
*Angela L. Wooten
Clerk to the Board*

Attachment: Resolution No. 2017-02-03 (1524 : Trillium Health Resources - Annual Report & Resolution No. 2017-02-03)



Board of Commissioners
AGENDA ITEM SUMMARY SHEET

New Business

Item Number: 6.D

Meeting Date: March 06, 2017

Submitted By: Charlie Bauman, Director
 Camden Economic Development Commission
 Prepared by: Angela Wooten

Item Title **Brand Name Change Recommendation Camden County Eco Industrial Park**

Attachments:

Summary:

County staff, along with real estate advisors, Jones Lang LaSalle, recommends a brand name change for the property currently known as the Camden County Eco Industrial Park. This recommendation is shared after careful consideration of future marketing opportunities available to the County as a result of our joint efforts with the JLL team. Importantly, the brand name change avails the County toward a renewed direction in the attraction of investment and employment opportunities for the Park. As well, this commitment enables the County to clearly state the purpose of the asset along with a continued effort to recruit companies committed to operating on an environmentally desirable level. Importantly, the Camden County Economic Development Commission fully supports this action and unanimously voted to accomplish this objective in its February 14, 2017 meeting.

Recommendation:

Therefore, it is recommended that the Camden County Board of Commissioners approve and adopt the brand name of Camden Commerce Park and directs County staff



to incorporate and implement the change in all marketing initiatives and materials going forward.



CAMDENCOUNTY

new energy. new vision.

Board of Commissioners AGENDA ITEM SUMMARY SHEET

Consent Agenda

Item Number: 8.A
Meeting Date: March 06, 2017

Submitted By: Angela Wooten, Clerk to the Board
Administration
Prepared by: Angela Wooten

Item Title **2016-11-21 BOC Minutes - Draft**

Attachments: 2016-11-21 BOC Minutes Draft Ltr (PDF)

Summary:

2016-11-21 BOC Minutes - Draft

Recommendation:

Review and Approve

CAMDEN COUNTY BOARD OF COMMISSIONERS

BOC - Regular Meeting – November 21, 2016

Camden County Board of Commissioners
BOC - Regular Meeting
November 21, 2016
7:00 PM
Historic Courtroom, Courthouse Complex
Camden, North Carolina

MINUTES

The regular meeting of the Camden County Board of Commissioners was held on November 21, 2016 in the Historic Courtroom, Camden, North Carolina. The following Commissioners were present:

WELCOME & CALL TO ORDER

Chairman McLain called the meeting to order at 7:00 PM.

Commissioners	Title	Status
P. Michael McLain	Chairman	Present
Sandra Duckwall	Commissioner	Present
Garry Meiggs	Vice Chairman	Absent
Clayton Riggs	Commissioner	Present
Tom White	Commissioner	Present
Staff	Title	Status
Stephanie Humphries	Finance Director	Present
Angela Wooten	Clerk to the Board	Present
John Morrison	County Attorney	Present
Lisa Anderson	Tax Administrator	Present
Dan Porter	Planning Director	Present

INVOCATION & PLEDGE OF ALLEGIANCE

Commissioner Tom White gave the Invocation and led the Pledge of Allegiance

PUBLIC COMMENTS

Tony Perry, Camden County Sheriff came forward to recognize the two County Commissioners coming off the board.

✳ Commissioner Sandra Duckwall

² Her work in getting a generator a few years ago, helped the Sheriff's Office

CAMDEN COUNTY BOARD OF COMMISSIONERS

Regular Meeting – November 21, 2016

23 and deputies provide needed services during Hurricane Matthew.

24

25 ✿ Chairman Michael McLain

26 ² His assistance with Mental health issues was greatly appreciated.

27 ² Provided a location for the Sheriff's Office shooting range.

28 CONSIDERATION OF AGENDA

29 Approve the agenda as presented

30	RESULT:	PASSED [UNANIMOUS]
31	MOVER:	Tom White, Commissioner
32	AYES:	McLain, Duckwall, Riggs, White
33	ABSENT:	Meiggs

34 PRESENTATIONS

35 A. Recognition of Outstanding Support during and after Hurricane Matthew

36 Chairman McLain presented 2 certificates to the South Mills Volunteer Fire department and
37 the South Mills Junior Firefighters Program for their work during Hurricane Matthew.

38 B. NC Forest Service - Annual Report

39 NORTH CAROLINA FOREST SERVICE ANNUAL REPORT
40 TO CAMDEN COUNTY COMMISSIONERS
41 FISCAL YEAR 2015-2016

42 PREPARED BY: CAMDEN COUNTY RANGER STEVE SUTTON

43 This letter highlights the North Carolina Forest Service's annual accomplishments for Camden County in
44 fiscal year July 2015 - June 2016. The NCFs is responsible for the protection and development of all
45 private and state wood lands in the county per general statutes. Camden County's woodland area
46 consists of 72,173 acres as listed in the 2007 Forest Statistics for North Carolina survey. At this time, I
47 would like to take the opportunity to explain our program areas and the accomplishments we made
48 this past year.

49 Fire Control

50 In 2015, we had a low amount of fire response calls due to a very wet year in which we responded to 2
51 calls that resulted in under an acre burning. We had 790 Burning Permits written by local agents and
52 acquired by landowners on line, 1 warning ticket written and 8 false alarm calls. Currently, in 2016 we
53 have responded to 9 fire calls with 3 of them being false alarms. We have 3 Volunteer Fire Departments,
54 which continue to be a tremendous asset to us in wildfire suppression. Their quick initial attack with us
55 minimizes fire damage and keeps fires small. I continue to visit each department and am working with
56 them on inter-agency policies and wild land fire training.

CAMDEN COUNTY BOARD OF COMMISSIONERSRegular Meeting – November 21, 2016

57 Forest Management

58 The NC Legislation passed a law in 2014 that requires the NC Forest Service to charge a fee for the
59 creation of certain wood land management plans for forest landowners which began on July 1, 2014.
60 This past year, with help from our District staff in Elizabeth City; we prepared 31 management plans and
61 3 assist letters for Camden landowners consisting of 1,217 acres. These plans help landowners meet
62 financial and personal objectives for their timberland. These plans address timber resources, wildlife,
63 aesthetics, water quality, soil protection, and/or recreation opportunities. Using information in their
64 management plans, Camden landowners replanted 246 acres of harvested Woodland, with site
65 preparing 100 of those acres and flat planting the rest. Release sprays were done on 200 acres to help
66 establish pines that were planted last year and 6 acres were burned by us for silvicultural purposes. We
67 are also responsible for conducting survival checks of last year planting projects, land measurement of
68 all projects funded with state funds using global positioning system instruments and collecting seed for
69 our nursery.

70 Water Quality Protection

71 We are also committed to randomly check on forestry logging operations. All forestry activities must
72 adhere to Forest Practice Guidelines and Best Management Practices. These laws and regulations
73 protect water quality and enable us to utilize forest resources in a sustainable manner. We conducted
74 65 inspections and re-inspections on loggers for 546 acres of forest harvesting activities in the county.

75 Information and Education

76 These programs are a vital part of our organization to educate the public in forestry and the prevention
77 of wildfires. We conducted 16 programs on chainsaw safety, fire prevention programs, VFD meetings,
78 GPS Fall Festival, South Mills Christmas Parade, and the Northeast AG Expo. Our Smokey Bear program
79 continues to be very popular at Grandy Primary school during Fire Prevention Week in October. We
80 passed out fire prevention material to 525 Kindergarten through Third grade students. Urban Assistance
81 and Pest Control We provide Camden citizens with advice and support on shade trees, yard trees,
82 windbreaks, and insect disease control. Urban assistance will continue to be a priority as the population
83 increases and more land is developed. In an effort to protect urban and forested areas, each year we
84 conduct aerial and ground surveys for forest pest outbreaks. We did not find any significant insect
85 activity this past year. We continually work with cooperative agencies, including the North Carolina
86 Department of Agriculture to monitor forest pest movements. They continue to work the Slow the
87 Spread Project to reduce the gypsy moth population.

88 Other Services

89 We are also involved in overall emergency response in Camden County, the State of North Carolina, and
90 the Southeast Compact. We stand ready for natural disaster recovery efforts such as hurricanes, floods,
91 tornadoes, and ice storms. My Assistant Ranger Frank Blankenship was dispatched to fight fires in the
92 states of Idaho, Washington, Montana, and Utah. He even helped on a fire in Brunswick County last
93 May. I am saddened to say he has been promoted to Yancey County Ranger in the mountain of NC as of
94 today. His job here is currently being advertised. With a County Ranger vacancy in Currituck also, I have
95 been asked to oversee and supervise the new assistant ranger there since June.

96 Summary

Attachment: 2016-11-21 BOC Minutes Draft Ltr (1595 : 2016-11-21 BOC Minutes - Draft)

CAMDEN COUNTY BOARD OF COMMISSIONERS

Regular Meeting – November 21, 2016

97 We had another good year in our program areas and appreciate the support of this board of
 98 commissioners and our cooperators in helping us achieve this success. If you need any assistance or
 99 have any questions, please feel free to contact me at 336-4332.

100 **C. Presentation by Tamim Choudhury**

101 Tamim Choudhury, Public Affairs Specialist, SBA Office of Disaster Assistance advises that
 102 anyone affected by Hurricane Matthew should apply for a Disaster Loan with FEMA
 103 immediately. There are 3 ways to apply;

- 104
 105 A. 1-800-659-2955
 106 B. www.SBA.gov
 107 C. Mobile Disaster Recovery Centers
 108

109 **Types of Disaster Loans**

- 110
 111 • **Business Physical Disaster Loans** - Loans to businesses to repair or replace disaster-
 112 damaged property owned by the business, including real estate, inventories, supplies,
 113 machinery and equipment. Businesses of any size are eligible. Private, non-profit
 114 organizations such as charities, churches, private universities, etc., are also eligible.
 115
 116 • **Economic Injury Disaster Loans (EIDL)** -Working capital loans to help small businesses,
 117 small agricultural cooperatives, and small businesses engaged in aquaculture, and most
 118 private, non-profit organizations of all sizes meet their ordinary and necessary financial
 119 obligations that cannot be met as a direct result of the disaster. These loans are
 120 intended to assist through the disaster recovery period.
 121
 122 • **Home Disaster Loans** - Loans to homeowners or renters to repair or replace disaster-
 123 damaged real estate and personal property, including automobiles.
 124

125 **Credit Requirements**

- 126
 127 • **Credit History** - Applicants must have a credit history acceptable to SBA.
 128 • **Repayment** - Applicants must show the ability to repay all loans.
 129 • **Collateral** - Collateral is required for physical loss loans over \$25,000 and all EIDL loans
 130 over \$25,000. SBA takes real estate as collateral when it is available. SBA will not decline
 131 a loan for lack of collateral, but requires you to pledge what is available.
 132

133 **Interest Rates**

134
 135 By law, the interest rates depend on whether each applicant has Credit Available Elsewhere. An
 136 applicant does not have Credit Available Elsewhere when SBA determines the applicant does
 137 not have sufficient funds or other resources, or the ability to borrow from non-government
 138 sources, to provide for its own disaster recovery. An applicant, which SBA determines to have

CAMDEN COUNTY BOARD OF COMMISSIONERS

Regular Meeting – November 21, 2016

139 the ability to provide for his or her own recovery is deemed to have Credit Available Elsewhere.
 140 Interest rates are fixed for the term of the loan. The interest rates applicable for this disaster
 141 are:
 142

	No Credit Available	Credit Available
Business Loans	4.000%	6.250%
Non-Profit Organization Loans	2.625%	2.625%
<u>Economic Injury Loans</u>		
• Businesses and Small Agricultural Cooperatives	4.000%	N/A
• Non-Profit Organizations	2.625%	N/A
Home Loans	1.563%	3.125%

143
 144 Loan Terms

145
 146 The law authorizes loan terms up to a maximum of 30 years. However, the law restricts
 147 businesses with credit available elsewhere to a maximum 7-year term. SBA sets the installment
 148 payment amount and corresponding maturity based upon each borrower's ability to repay.

149
 150 Loan Limits

- 151
- 152 • **Business Loans** - The law limits business loans to \$2,000,000 for the repair or
 153 replacement of real estate, inventories, machinery, equipment and all other physical
 154 losses. Subject to this maximum, loan amounts cannot exceed the verified uninsured
 155 disaster loss.
 - 156
 - 157 • **Economic Injury Disaster Loans (EIDL)** - The law limits EIDLs to \$2,000,000 for alleviating
 158 economic injury caused by the disaster. The actual amount of each loan is limited to the
 159 economic injury determined by SBA, less business interruption insurance and other
 160 recoveries up to the administrative lending limit. EIDL assistance is available only to
 161 entities and their owners who cannot provide for their own recovery from non-
 162 government sources, as determined by the U.S. Small Business Administration.
 - 163
 - 164 • **Business Loan Ceiling** - the 52,000,000 statutory limits for business loans applies to the
 165 combination of physical, economic injury, mitigation and refinancing, and applies to all
 166 disaster loans to a business and its affiliates for each disaster. If a business is a major
 167 source of employment, SBA has the authority to waive the \$2,000,000 statutory limit.
 - 168
 - 169 • **Home Loans** - SBA regulations limit home loans to \$200,000 for the repair or
 170 replacement of real estate and \$40,000 to repair or replace personal property. Subject
 171 to these maximums, loan amounts cannot exceed the verified uninsured disaster loss.

172
 173 Restrictions are there on Loan Eligibility

CAMDEN COUNTY BOARD OF COMMISSIONERS

Regular Meeting – November 21, 2016

- 174
- 175
- 176
- 177
- 178
- 179
- 180
- 181
- 182
- 183
- 184
- 185
- 186
- 187
- **Uninsured Losses** - Only uninsured or otherwise uncompensated disaster losses are eligible. Any insurance proceeds which are required to be applied against outstanding mortgages are not available to fund disaster repairs and do not reduce loan eligibility. However, any insurance proceeds voluntarily applied to any outstanding mortgages do reduce loan eligibility.
 - **Ineligible Property** - Secondary homes, personal pleasure boats, airplanes, recreational vehicles and similar property are not eligible, unless used for business purposes. Property such as antiques and collections are eligible only to the extent of their functional value. Amounts for landscaping, swimming pools, etc., are limited.
 - **Noncompliance** - Applicants who have not complied with the terms of previous SBA loans may not be eligible. This includes borrowers who did not maintain flood and/or hazard insurance on previous SBA loans.

Help with Funding Mitigation Improvements

188

189

190

191

192

193

194

195

196

197

198

199

If your loan application is approved, you may be eligible for additional funds to cover the cost of improvements that will protect your property against future damage. Examples of improvements include retaining walls, seawalls, sump pumps, safe rooms, etc. Mitigation loan money would be in addition to the amount of the approved loan, but may not exceed 20 percent of total amount of physical damage to real property, including leasehold improvements, and personal property as verified by SBA to a maximum of \$200,000 for home loans. It is not necessary for the description of improvements and cost estimates to be submitted with the application. SBA approval of the mitigating measures will be required before any loan increase.

Help Available for Refinancing

- 200
- 201
- 202
- 203
- 204
- 205
- 206
- 207
- 208
- 209
- 210
- 211
- **SBA** can refinance all or part of prior mortgages that are evidenced by a recorded lien, when the applicant (1) does not have credit available elsewhere, (2) has suffered substantial uncompensated disaster damage (40 percent or more of the value of the property or 50% or more of the value of the structure), and (3) intends to repair the damage.
 - **Businesses** - Business owners may be eligible for the refinancing of existing mortgages or liens on real estate, machinery and equipment, up to the amount of the loan for the repair or replacement of real estate, machinery, and equipment.
 - **Homes** - Homeowners may be eligible for the refinancing of existing liens or mortgages on homes, up to the amount of the loan for real estate repair or replacement.

Relocate

CAMDEN COUNTY BOARD OF COMMISSIONERS

Regular Meeting – November 21, 2016

213 You may use your SBA disaster loan to relocate. The amount of the relocation loan depends on
 214 whether you relocate voluntarily or involuntarily. If you are interested in relocation, an SBA
 215 representative can provide you with more details on your specific situation.

Insurance Requirements for Loans

217 To protect each borrower and the Agency, SBA may require you to obtain and maintain
 218 appropriate insurance. By law, borrowers whose damaged or collateral property is located in a
 219 special flood hazard area must purchase and maintain flood insurance. SBA requires that flood
 220 insurance coverage be the lesser of 1) the total of the disaster loan, 2) the insurable value of
 221 the property, or 3) the maximum insurance available.

222 Once approved, the applicant is under no obligation to take the loan. Once the deadline is
 223 passed no applications will be accepted.

4. OLD BUSINESS

225 None

5. PUBLIC HEARINGS

227 None

6. NEW BUSINESS**A. Monthly Tax Report - October 2016**

**MONTHLY REPORT OF THE TAX ADMINISTRATOR TO THE
 CAMDEN COUNTY BOARD OF COMMISSIONERS**

OUTSTANDING TAX DELINQUENCIES BY YEAR

YEAR	REAL PROPERTY	PERSONAL PROPERTY
2015	107,065.76	6,681.81
2014	47,769.23	4,245.32
2013	21,542.50	7,408.91
2012	13,625.10	9,658.31
2011	8,907.94	7,609.53
2010	6,704.56	5,313.34
2009	4,716.95	5,047.63
2008	4,240.38	5,334.32

CAMDEN COUNTY BOARD OF COMMISSIONERS

Regular Meeting – November 21, 2016

2007	4,010.88	7,294.85
2006	1,544.50	12,644.98
TOTAL REAL PROPERTY TAX UNCOLLECTED		220,127.80
TOTAL PERSONAL PROPERTY UNCOLLECTED		71,239.00
TEN YEAR PERCENTAGE COLLECTION RATE		99.57%
COLLECTION FOR 2016 vs. 2015		16,928.74 vs. 17,713.93

LAST 3 YEARS PERCENTAGE COLLECTION RATE

2015	98.29%
2014	99.23%
2013	99.59%

THIRTY LARGEST UNPAID ACCOUNTS

SEE ATTACHMENT "A"

THIRTY OLDEST UNPAID ACCOUNTS

SEE ATTACHMENT "B"

**EFFORTS AT COLLECTION IN THE LAST 30 DAYS
ENDING October 2016
BY TAX ADMINISTRATOR**

19	NUMBER DELINQUENCY NOTICES SENT
16	FOLLOW UP REQUESTS FOR PAYMENT SENT
10	NUMBER OF WAGE GARNISHMENTS ISSUED
6	NUMBER OF BANK GARNISHMENTS ISSUED
7	NUMBER OF PERSONAL PHONE CALLS MADE BY TAX ADMINISTRATOR TO DELINQUENT TAXPAYER
0	NUMBER OF PERSONAL VISITS CONDUCTED (COUNTY OFFICES)
0	PAYMENT AGREEMENTS PREPARED UNDER AUTHORITY OF TAX ADMINISTRATOR

CAMDEN COUNTY BOARD OF COMMISSIONERS

Regular Meeting – November 21, 2016

1	NUMBER OF PAYMENT AGREEMENTS RECOMMENDED TO COUNTY ATTORNEY
0	NUMBER OF CASES TURNED OVER TO COUNTY ATTORNEY FOR COLLECTION (I.D. AND STATUS)
1	REQUEST FOR EXECUTION FILES WITH CLERK OF COURTS
3	NUMBER OF JUDGMENTS FILED

230 **RESULT:** **APPROVED AS PRESENTED [UNANIMOUS]**
231 **MOVER:** Tom White, Commissioner
232 **AYES:** McLain, Duckwall, Riggs, White
233 **ABSENT:** Meiggs

234 **B. Resolution - US HWY 17**

235 **RESOLUTION BY THE CAMDEN COUNTY BOARD OF COMMISSIONERS SUPPORTING**
236 **THE UPGRADING OF U.S. HIGHWAY 17 IN NORTHEAST NORTH CAROLINA TO**
237 **INTERSTATE STANDARDS**

238
239 WHEREAS, US Highway 17, the Ocean Highway, was once the primary north-south transportation
240 route in the coastal plain of eastern North Carolina; and,

241
242 WHEREAS, US Highway 17 continues to be the primary corridor of trade for northeastern North
243 Carolina; and,

244
245 WHEREAS, there is a substantial amount of poverty, unemployment, underemployment, and
246 economic distress in northeastern North Carolina due to the lack of economic opportunity that
247 adequate highways can help to provide; and,

248
249 WHEREAS, US Highway 17 as part of the proposed I-87 Interstate Route will enable northeastern
250 North Carolina to recruit and retain industrial jobs whose companies require access to interstate-
251 quality highways to link products and services to eastern US markets; and,

252
253 WHEREAS, the Ports of Virginia are cooperating in the joint Virginia-North Carolina effort to
254 expand Foreign Trade Zone #20 from Northeastern Virginia into northeastern North Carolina
255 including Currituck, Camden, Pasquotank, Perquimans, Chowan, Bertie, Gates, and Hertford
256 Counties; and,

257
258 WHEREAS, waterborne foreign imports accessing the United States through Ports of Virginia and
259 Ports of North Carolina via the emerging Piedmont Atlantic Megaregion will be transported along
260 U.S. Highway 17 as identified within the North Carolina Maritime Strategy; and,

261
262 WHEREAS, the completion of the I-87 Interstate Route from the Ports of Virginia to Raleigh will
263 require funding and work over many years; and,

264

CAMDEN COUNTY BOARD OF COMMISSIONERS

Regular Meeting – November 21, 2016

265 WHEREAS, the upgrading of US Highway 17 to interstate standards can coincide with the expansion
 266 of Foreign Trade Zone #20 into the area, creating a synergy to ignite economic development in
 267 northeastern North Carolina.

268
 269 NOW, THEREFORE, BE IT RESOLVED THAT THE CAMDEN COUNTY BOARD OF COMMISSIONERS
 270 DOES HEREBY REQUEST THE UPGRADING OF US HIGHWAY 17 IN NORTHEASTERN NORTH
 271 CAROLINA TO INTERSTATE STANDARDS BE FUNDED IMMEDIATELY AND THE PLANNING AND
 272 COMPLETION OF THIS PORTION OF INTERSTATE I-87 BE UNDERTAKEN AS QUICKLY AS
 273 POSSIBLE.

274
 275 This the 21st day of November, 2016.

276	RESULT:	APPROVED AS PRESENTED [UNANIMOUS]
277	MOVER:	Clayton Riggs, Commissioner
278	AYES:	McLain, Duckwall, Riggs, White
279	ABSENT:	Meiggs

280 C. Establishment of a Joint School Committee

281 In consideration of the upcoming FY2017-2018 County Budget cycle and concerns with the
 282 recently adopted classroom student cap by the State, the School Superintendent's Office
 283 has presented an option to increase communication between the County Commissioners
 284 and the Board of Education. The option is to create a Joint BOC/BOE Committee that would
 285 discuss school budgetary matters affecting the annual operating budget.

286
 287 The initial recommendation includes a Committee membership consisting of two Board of
 288 Education members and two County Commissioners. As part of this process,
 289 recommendations of the School Committee would be presented to the two Boards for
 290 consideration and approval.

291
 292 Final action regarding budgetary matters would then be ratified during the annual Budget
 293 adoption. As a note, this Committee would function separate and apart from the current
 294 Adequate Public Facilities Committee whose purpose is to analyze school capital needs in
 295 consideration of average daily school attendance capacity

296
 297 Commissioner Riggs made a motion to use the APFO committee to meet monthly and take
 298 this agenda under consideration.

299 Use the APFO committee to meet monthly and take this agenda under consideration.

300 In consideration of the upcoming FY2017-2018 County Budget cycle and concerns with the
 301 recently adopted classroom student cap by the State, the School Superintendent's Office
 302 has presented an option to increase communication between the County Commissioners
 303 and the Board of Education. The option is to create a Joint BOC/BOE Committee that would
 304 discuss school budgetary matters affecting the annual operating budget.

305

CAMDEN COUNTY BOARD OF COMMISSIONERS

Regular Meeting – November 21, 2016

306 The initial recommendation includes a Committee membership consisting of two Board of
307 Education members and two County Commissioners. As part of this process,
308 recommendations of the School Committee would be presented to the two Boards for
309 consideration and approval.

310
311 Final action regarding budgetary matters would then be ratified during the annual Budget
312 adoption. As a note, this Committee would function separate and apart from the current
313 Adequate Public Facilities Committee whose purpose is to analyze school capital needs in
314 consideration of average daily school attendance capacity

315
316 Commissioner Riggs made a motion to use the APFO committee to meet monthly and take
317 this agenda under consideration.

318 **RESULT:** PASSED [UNANIMOUS]
319 **MOVER:** Clayton Riggs, Commissioner
320 **AYES:** McLain, Duckwall, Riggs, White
321 **ABSENT:** Meiggs

322 D. Administrative Building - Design Services

323 Commissioner Sandra Duckwall made a motion to approve moving forward with the
324 advertising of an RFQ for Architectural/Engineering Services in consideration of Option #2.

325 **RESULT:** APPROVED AS PRESENTED [UNANIMOUS]
326 **MOVER:** Sandra Duckwall, Commissioner
327 **AYES:** McLain, Duckwall, Riggs, White
328 **ABSENT:** Meiggs

329 E. LANGUAGE ACCESS PLAN

330 County Manager, Manager Brillhart advised that a Four-Factor Analysis and Language
331 Access Plan for Persons with Limited English Proficiency (LEP) have been created for
332 Camden County. The Federal Government requires the establishment of a Language Access
333 Plan (LAP) and implementation of strategies for persons of Limited English Proficiency
334 affecting local governments that are a recipient of and involved in Federal assisted
335 programs.

336
337 The attached **Four-Factor and Language Access Plan for Limited English Proficiency**
338 **(LEP)** was development to meet this requirement for Camden County. Once approved by
339 the Board of Commissioners, the analysis and Plan will be transmitted to the local office in
340 North Carolina of the U.S. Department of Agriculture - Rural Development. At this time,
341 Camden County does not meet the minimum threshold for persons with LEP. Camden does
342 have a language translator application on the County website that can be used to assist
343 individuals using the website to read information and documents in the native language. In

Attachment: 2016-11-21 BOC Minutes Draft Ltr (1595 : 2016-11-21 BOC Minutes - Draft)

CAMDEN COUNTY BOARD OF COMMISSIONERS

Regular Meeting – November 21, 2016

344 addition, the County can use specific language translators where needed to provide
 345 language assistance to persons directly affected by specific programs and capital projects.
 346

347 THE COUNTY OF CAMDEN, NORTH CAROLINA
 348 FOUR-FACTOR ANALYSIS
 349 AND
 350 LANGUAGE ACCESS PLAN
 351 FOR LIMITED ENGLISH PROFICIENCY (LEP)

352 Four (4) - Factor Analysis For Limited English Proficiency

353 The purpose in preparing this analysis in compliance with Executive Order 13166 is for the
 354 development of the following Language Access Plan (LAP) for persons with Limited English
 355 Proficiency (LEP).

356 Title VI of the Civil Rights Act of 1964 is the federal law which protects individuals from
 357 discrimination on the basis of their race, color, or national origin in programs that receive federal
 358 financial assistance. In certain situations, failure to ensure that persons who have limited English
 359 proficiency can effectively participate in, or benefit from, federally assisted programs may violate
 360 Title VI's prohibition against national origin discrimination.

361 Access to language assistance through a particular service or benefit, under Title VI may be
 362 available for persons who, as a result of national origin, do not speak English as their primary
 363 language and who have limited ability to speak, read, writes, or understands English in order to
 364 effectively interact with local government and social service agencies.

365 The following Four-Factor Analysis serves as a guide for determining which language assistance
 366 measures Camden County will undertake in order to guarantee access to relative County
 367 information by persons with Limited English Proficiency.

368 1. The number and proportion of LEP persons served or encountered in the eligible
 369 service population - served or encountered includes those persons who would be
 370 served by the recipient if the person received education and outreach and the recipient
 371 provided sufficient language services.
 372

373 Camden County utilized demographic data from the Census Bureau's American
 374 Community Survey (ACS) 2015 for all citizens 18 years and over. In consideration of this
 375 data, Camden County, NC does not meet the 1,000 or 5% LEP threshold for Hispanic or
 376 Latino. This census data references that 2.8% (288) of our total population of 10,309
 377 speak Spanish. Of those 288, (34.5%), which is equal to 99 persons, speak English well.
 378 This leaves a total of 189 or 1.8% of our total population who speaks Spanish only.
 379

380 Within the Camden Point community located in Shiloh Township of South Camden
 381 County, there exists a Vietnamese fishing village. Based on census data, Camden County
 382 does not meet the 1,000 or 5% LEP person's threshold for Vietnamese. Although 113
 383 people of Vietnamese descent representing 1.1% of our total population speak
 384 Vietnamese. 30% (34 persons) speak English well. This leaves a total of 79 (0.78%) who
 385 speak only Vietnamese.

CAMDEN COUNTY BOARD OF COMMISSIONERS

Regular Meeting – November 21, 2016

386
387
388 Past county capital projects using Rural Development funds provided access to non-
389 English speaking residents through the county's online website language translation
390 process. We use free translation programs to print out an explanation in Spanish and
391 Vietnamese for those that request the translation.

392
393 Camden County holds public hearings for projects that require it. The public notice
394 states the information is available in Spanish upon request. An identified and qualified
395 translator for Spanish and Vietnamese is available when needed. However, at past
396 hearings there have been no participants from the non-English speaking community.
397

- 398 2. The frequency with which the LEP individuals come into contact with Rural
399 Development funded programs, activities, and services -

400
401 Construction of the Camden Intermediate School and major renovations to the County's
402 Historic Courthouse were funded through the USDA Rural Development program. The
403 Camden County School Board ensures effective communication between the LEP
404 persons of Spanish and Vietnamese language proficiency who are parents of students at
405 the Intermediate School. The Courthouse renovations do not provide direct assistance
406 to individuals.
407

- 408 3. The nature and importance of the program, activity, or service provided by the program
409

410 Our proposed USDA Rural Development projects are capital infrastructure based and do
411 not provide direct assistance to individuals. As a result, LEP persons rarely come into
412 contact with the projects. However, all citizen participations activities are open to the
413 general public and is noted to be available in Spanish and other languages such as
414 Vietnamese upon request.
415

- 416 4. The resources available and costs to the recipient -

417
418 When publishing mandatory public notices and press releases, Camden County will
419 make the information available upon request in Spanish. We use a free translation
420 application (Google Translator) on the Camden County website to translate this
421 information.
422

423 In addition, Camden County can provide a qualified Spanish translator at no cost to the
424 residents and minimal costs to the County. Our translator lives and works in our
425 community. Public hearing notices will be placed on our website advising the Spanish
426 community the documents are available to them upon request
427

428 We will keep close contact with the Vietnamese community to identify any increase in
429 the LEP population that would require the County to provide translation assistance.
430

Language Access Plan for Limited English Proficiency

431
432
433

Attachment: 2016-11-21 BOC Minutes Draft Ltr (1595 : 2016-11-21 BOC Minutes - Draft)

CAMDEN COUNTY BOARD OF COMMISSIONERS

Regular Meeting – November 21, 2016

434 **Introduction**

435 With the completion of a Four Factor Analysis for Camden County, we have identified the types of
 436 language assistance that needs to be provided in compliance with the County's implementation
 437 of Federally Assisted Programs. In compliance with Title VI of the Civil Rights Act of 1964 the
 438 County has prepared this Language Access Plan in order to ensure that persons who have limited
 439 English proficiency can effectively participate in, or benefit from, federally assisted programs.





440 Persons who, as a result of national origin, do not speak English as their primary language and
 441 who have limited ability to speak, read, write, or understand English may be entitled to language
 442 assistance under Title VI in order to receive a particular service, benefit, or encounter. As
 443 described in Executive Order 13166, LEP persons are those who do not speak English as their
 444 primary language and have limited ability to read, speak, write or understand English.

445

446 **Limited English Proficiency Population**

447 According to the U.S. Census Bureau's 2015 American Community Survey (ACS) data, Camden
 448 County, North Carolina has a population of 10,309. A breakdown of the number of persons whose
 449 first language is not English is shown in the chart below. In addition, the chart also breaks down
 450 those percentages by indicating how many of these can also speak English well.

451

Language	Percent Who Speak	Percent Who Speak English Well
Spanish	 2.8%	 34.5%
Vietnamese	 1.1%	 30.0%

452

453

454 1) Camden County, North Carolina does not meet the 1,000 or 5% LEP person threshold for
 455 Spanish or Vietnamese. 2.8% (288) of our total population of 10,309 speak Spanish. Of those
 456 (34.5%) speak English well. This leaves a total of 189 persons (1.8% of our total population)
 457 who speak Spanish only.

458

459 2) Camden County, North Carolina does not meet the 1,000 or 5% LEP person threshold for
 460 Vietnamese. Although 1.1% (113) of our total population of 10,309 speak Vietnamese. 30.0%
 461 (34) of those speak English well. This leaves a total of 0.78% (79 persons) who only speak
 462 Vietnamese

463

464 **Language Assistance**

465

466 Public notices are available upon request in Spanish. Camden County uses a free translation
 467 website to translate this information. Both Spanish and Vietnamese translators live in our
 468 community and are available to assist as requested.

469

CAMDEN COUNTY BOARD OF COMMISSIONERS

Regular Meeting – November 21, 2016

470 A copy of the Language Access Plan will be available to all staff. And Language
 471 Identification Flash Cards will be available to all staff members when needed. County staff
 472 will be advised to document any requests for language assistance.

473
 474 Contact will be made to family or friends of LEP persons to assist in language
 475 interpretation. Camden County will also coordinate written translations where a
 476 substantive number of people speak a language other than English.

477
 478 **Frequency of Contact with LEP Population**

479
 480 Our County administrative staff and Sheriff s Office comes into contact with the LEP
 481 Population more than other employees due to water bill payments, property and vehicle
 482 tax bills, issuing traffic and other citations and general questions specific to public safety.

483
 484
 485 **Notices to LEP Persons**

486
 487 Mandatory public notices are published with the option of having the information available
 488 upon request in Spanish or other translation free of charge. Camden County uses the free
 489 Google Translator application on our website to translate this information. As needed,
 490 Camden County is able to provide a qualified Spanish or Vietnamese translator at no cost to
 491 the residents and minimal costs to the County. Our translators live within Camden County.
 492 The County will also use the free Language Identification Flash Card feature in the future as
 493 warranted.

494
 495 **Vital Document Translations**

496
 497 Any specific Camden County notification that would directly impact individuals of the LEP
 498 Population is considered a vital document.

- 499
- 500 a. Public infrastructure or community improvement grant funds impacting an area
 501 where LEP persons are located will be considered vital.
 - 502 b. Notification of an impending natural disaster and the location of Emergency Shelters
 503 before, during and after are considered vital.
 - 504 c. Contact with the Camden Sheriff s Office due to an emergency is considered vital.

505
 506 **Monitoring and Updating the Language Access Plan**

- 507
- 508 1) The County will continue in keeping close contact with the Spanish and
 509 Vietnamese community to identify any increase in the population that would
 510 require Camden County to provide an LEP to them.
 - 511 2) An annual review will be conducted via U.S. Census updates to determine the
 512 following:
 - 513 • Identify the current LEP population in the area
 - 514 • Assess whether or not the need for translation services have changed
 - 515 • Assess whether the LAP has been effective and sufficient

CAMDEN COUNTY BOARD OF COMMISSIONERS

Regular Meeting – November 21, 2016

516

517 **RESULT:** APPROVED AS PRESENTED [UNANIMOUS]
 518 **MOVER:** Clayton Riggs, Commissioner
 519 **AYES:** McLain, Duckwall, Riggs, White
 520 **ABSENT:** Meiggs

521 F. TRAVEL POLICY



TRAVEL POLICY

*(Approved by the Board of Commissioner's – 11/21/2016)*522
523
524
525

I. *Purpose – The intent of this policy is to make uniform provision for reimbursement of necessary expenses of County employees or officials of the County who are required to travel within or outside the County boundaries in the performance of their duties and in the interest of County affairs. These policies are intended to apply to employees, board members, or other persons on official County business.*

526
527
528
529
530
531
532
533

II. *Policy Administration - The respective department heads are responsible for the administration of the provisions of this policy. Department heads are authorized to approve travel reimbursements for the employees under their supervision except where otherwise stated. For the purposes of administering this policy, Board Members or other County delegates or officials will be considered "employees" and thereby reimbursed per this policy.*

534
535
536
537III. *General Policy*538
539
540
541
542
543

A. *Travel - Camden County recognizes that employees and officials are required to travel both within and outside the State of North Carolina for the purpose of representing the County at meetings and professional associations, as well as for training to enhance their skills regarding the performance of their various positions within the County Government.*

544
545
546
547
548
549
550
551

It is inherently understood in this policy that an individual traveling on official County business is expected to exercise the same care in incurring expenses that a prudent person would exercise if traveling on personal business and expending personal funds. Excess costs, circuitous routes, delays, or luxury accommodations and services unnecessary, unjustified, or solely for the convenience or personal preference of the traveler in the performance of official County business are not acceptable under this standard, and travelers will be held responsible for unauthorized costs and additional expenses incurred for personal preference or convenience.

552
553
554

Requests for travel approval should be submitted to the County Manager and Finance for pre-audit and approval prior to departure.

555
556

See Exhibit A at the end of the Policy for the Travel Request form

557
558*In-District*559
560*Daily Travel (not overnight)*

CAMDEN COUNTY BOARD OF COMMISSIONERS

Regular Meeting – November 21, 2016

561 Normally, allowances shall not be paid to employees for meals if travel does not involve
 562 travelling out-of-district (35 mile radius of the Courthouse). Employees may be reimbursed for
 563 lunch when the employee's job requires his/her attendance at the meeting of a board,
 564 commission, committee or council in his official capacity **and** the meal is preplanned as part of
 565 the meeting. Breakfast and dinner reimbursements do not apply to Travel that does not
 566 include an overnight stay except as a preplanned part of the meeting or for the benefit of the
 567 employer. In accordance with IRS regulations, any payments for meals, other than inclusive in
 568 the meeting agenda, provided for the benefit of the employer, or those paid as a part of
 569 overnight travel, will be reported on the employee's or official's W2 form as "taxable fringe
 570 benefit". Normal reimbursement rates still apply.

Overnight Travel

572 Overnight travel does not apply to In-District Travel.

Out-of-District

573 Out of District travel consists of travelling further than a 35 mile radius of the Courthouse.

Daily Travel (not overnight)

574 Employees may be reimbursed for meals when the employee's job requires his/her attendance
 575 at the meeting of a board; commission, committee or council in his official capacity and the
 576 meeting coincides with the following schedule.

577 To be eligible, the employee must:

- 578 • Breakfast – depart duty station prior to 6:00 am
- 579 • Lunch – depart duty station prior to 10:00 am and/or return to duty station after 2:00 pm
- 580 • Dinner – return to duty station after 8:00 pm

581 Travel that does not include an overnight stay except as a preplanned part of the meeting or for
 582 the benefit of the employer is considered taxable. In accordance with IRS regulations, any
 583 payments for meals, other than inclusive in the meeting agenda, provided for the benefit of the
 584 employer, or those paid as a part of overnight travel, will be reported on the employee's or
 585 official's W2 form as "taxable fringe benefit". Normal reimbursement rates still apply.

Overnight Travel

586 Employees may receive non-taxable allowances for meals when overnight travel is required.
 587 Partial days of travel will be reimbursable by the following schedule.

588 To be eligible, the employee must:

- 589 • Breakfast – depart duty station prior to 6:00 am
- 590 • Lunch – depart duty station prior to 10:00 am and/or return to duty station after 2:00 pm
- 591 • Dinner – return to duty station after 8:00 pm, if stopping for dinner causes a return after
 592 8:00 pm dinner will not be eligible.

- 593
- 594
- 595
- 596
- 597
- 598
- 599
- 600
- 601
- 602
- 603
- 604
- 605 B. Mileage Allowance – Travel by privately owned vehicle when necessary and allowable will be
 606 reimbursed using the IRS reimbursement rate based on the shortest route of travel. The annual
 607 rate will be reported to staff and officials by the Finance Office annually.
- 608
- 609 C. Meal Reimbursement Rates – Maximum reimbursement for the cost of meals in connection with
 610 County business will be at the federal reimbursement rates published at
 611 <http://www.gsa.gov/portal/category/104711>. Receipts of actual expenditures are required for
 612 reimbursement. The County expects that all travelers will take advantage of free in-hotel
 613 breakfast when offered. Tips are reimbursable up to 18%. Receipts must be itemized and
 614 alcohol must not be purchased with county funds. Please make every reasonable effort to not
 615 include charges for alcohol or travel companion meals.

CAMDEN COUNTY BOARD OF COMMISSIONERS

Regular Meeting – November 21, 2016

616
617
618
619
620
621
622
623
624
625

D. Travel Reimbursement – The travel reimbursement form provided for the traveler should be turned in for reimbursement within 10 days of the employee's return. This form lists all mileage, private or public transportation, lodging, meals, registration, and other travel expenses which are reimbursable. Itemized receipts for lodging, meals, registration, and private or public transportation are to be attached to and made a part of the reimbursement form. For taxis, airport shuttles, and buses, receipts may not be available or provided; therefore, attach, if possible. The reimbursement form must be approved by the department head and signed by the employee before being presented to the Finance Office for reimbursement.

626 See Exhibit B at the end of the Policy for the Travel Reimbursement form.

627
628
629
630
631

E. Transportation Cost of Employee – Payment of mileage allowance or actual cost of public transportation as applicable. If rental vehicles are used for both business and non-business purposes, reimbursement to the county for the non-business portion will apply.

632 IV. Authorized Travel Modes

633
634
635
636
637
638
639
640

A. County-owned Vehicle – This method of transportation is to be used whenever a county vehicle is available. Exceptions to this requirement must be approved by the County Manager. The department head may authorize reimbursement to the employee for exact operation expenses in circumstances where direct credit charges cannot be made to the county such as gas or unforeseen immediate needs for maintenance and the vehicle card is unavailable. (Please notify Maintenance, the Department Head and the Finance Officer as soon as reasonable.)

641
642
643
644

B. Private owned Vehicle – When no county vehicle is available, this mode may be used if specifically authorized by the appropriate department head and the County Manager. Reimbursement for operation expense shall be limited to the mileage allowance.

645
646
647
648
649

C. Transportation by Common Carrier – Reimbursement for air, rail, or bus fare is limited to business or coach fare, substantiated by a receipt. Quotes must be obtained from more than one (1) common carrier, if multiple carriers exist, and documentation that the lowest fare available was used must be submitted on the travel request form.

650
651
652
653

D. Rental Vehicles – Reimbursement of rental vehicle expenses will not be authorized without prior approval by County Manager. If approved, the rented vehicle should be secured at the lowest practical cost.

654
655 V. Travel Destination

656
657
658
659
660
661

A. Local Travel – County employees, who by the normal nature of their duties, are required to travel regularly within the county or district and are individually authorized by the appropriate department head, are eligible for reimbursement of transportation expense on a monthly basis.

662
663
664
665
666
667
668
669
670

B. Travel Outside the County/District – Approved travel expenses outside the county for county purposes or purposes in the best interest of the county, such as training, conferences, professional meetings, etc., may be reimbursed to the limits of the policy for:

1. Transportation cost
2. Lodging
3. Meals
4. Registration costs
5. Necessary incidental expenses (parking, tolls, etc.)

CAMDEN COUNTY BOARD OF COMMISSIONERS

Regular Meeting – November 21, 2016

- 671 C. Lodging – To receive reimbursement for lodging expenses, an itemized hotel bill must be
- 672 attached to the reimbursement form. Hotel room rates are allowable up to the federal
- 673 government rate. The County Manager must approve room rates when they exceed the
- 674 allowable rate.
- 675
- 676 D. Registration Cost– Registration costs should be paid directly by the County. When an employee
- 677 personally pays a registration fee, a receipt for payment should be obtained and is preferable
- 678 to a canceled check for reimbursement purposes. Additional registration costs for
- 679 recreational and entertainment activities will not be paid by the County. Meal functions are
- 680 not included in this requirement, and are eligible for payment by the County in lieu of the
- 681 meal reimbursement payment.
- 682
- 683 E. Out-of-State Travel – Out-of-state travel begins when the employee leaves the State and
- 684 remains in effect until the employee returns to the State. Out-of-state travel requests by
- 685 employees and department heads must be approved by the County Manager.
- 686
- 687 F. Credit Card– Employees and officials authorized to use a County credit card may elect to use
- 688 them instead of reimbursement; however, meals are still subject to the meal rates listed in
- 689 Section III. C. of the Policy. All receipts
- 690 For expenditures must be submitted to the Finance Office in order for the expenditures to be
- 691 approved.
- 692
- 693 G. Travel with Others - When two or more employees are traveling to the same destination,
- 694 maximum use shall be made of special group travel discounts and joint use of the
- 695 transportation including taxi cabs, County-owned, or privately owned vehicles. Travel with
- 696 representatives of other government units is encouraged whenever possible for expense
- 697 sharing.
- 698
- 699 H. Commuting– No reimbursement shall be made for use of a personal vehicle in commuting from
- 700 an individual’s home to his/her office.
- 701
- 702 I. Other Costs - Reasonable parking fees, tolls, taxi charges, and expenses of a similar nature,
- 703 when appropriate to the travel, are reimbursable upon submission of appropriate
- 704 documentation of the same. The Finance Officer or County Manager shall approve or
- 705 disapprove all other expense reimbursements not clearly defined in the Policy or those which
- 706 have been questioned.
- 707
- 708 J. Telephone Calls – Employees are not allowed to charge long distance telephone calls to the
- 709 County for calls of a personal nature, except as stated below. All long distance calls that are to
- 710 be paid by the County are those made pursuant to the employee conducting official County
- 711 business. An employee traveling to a location outside the local calling area is allowed one (1)
- 712 “safe arrival” call upon arriving at the destination. Additionally, employees may properly be
- 713 reimbursed for emergency calls approved by the Department Head. An example of such is a
- 714 call made when an employee calls home to inform someone that the travel period has been
- 715 extended beyond original plans due to unforeseen reasons.

VI. Extraordinary Travel or Cost

In instances of travel not covered by this policy, or where the actual necessary costs exceed the maximum reimbursement allowed and the travel is in the best interest of the county, the County Manager may approve reimbursement of actual cost beyond the maximums stated herein.

VII. Travel Expenses not Addressed by this Policy

725

Attachment: 2016-11-21 BOC Minutes Draft Ltr (1595 : 2016-11-21 BOC Minutes - Draft)

CAMDEN COUNTY BOARD OF COMMISSIONERS

Regular Meeting – November 21, 2016

726 *Any travel expenses falling outside the realm of this policy must be approved by the County*
 727 *Manager.*

728
 729 VIII. *Travel Advances*

730
 731 *Hotel accommodations may be paid directly to the hotel in advance by County credit card. The*
 732 *itemized receipt must be turned in with your travel reimbursement. Any other travel advance*
 733 *must be approved by the County Manager using the Travel Advance Form.*

734
 735 *See Exhibit C at the end of the Policy for the Travel Advance Form*

736
 737 IX. *Travel Procedure*

738
 739 A. *A Travel Request Form should be submitted to the Department Head for approval and*
 740 *forwarded to the Finance Department for pre-audit purposes. A Travel Advance Request*
 741 *should be included with this form if needed/requested.*

742
 743 B. *Upon return, the Travel Reimbursement form and supporting itemized receipts (includes*
 744 *meals, hotel and allowable incidentals) must be submitted to the Department Head for*
 745 *approval. After approval by the Department Head, the form should be forwarded to the*
 746 *Finance Department.*

747
 748 C. *The Finance Department will determine that the travel form and receipts have been properly*
 749 *approved, that they are mathematically correct, and that requested reimbursements agree to*
 750 *submitted receipts, when required, and are within the limits set by the Policy. If an error in the*
 751 *reimbursement request is found, the requesting party will be informed and the error will be*
 752 *corrected before payment is made.*

753
 754 D. *Trip Cancellation – When an employee cancels an approved trip and the County has paid*
 755 *airfare, registration and other related fees or issued a travel advance, a memo must be sent to*
 756 *the Finance Department explaining the cancellation. Non-refundable expenditures will be*
 757 *reviewed on a case by case basis by the County Manager.*

758
 759 X. *The following items are not reimbursable:*

- 760
 761 *(1) Any expense not supported by a receipt*
 762 *(2) Meals included in registration*
 763 *(3) Travel to and from work place*
 764 *(4) Souvenirs from the trip*
 765 *(5) Items purchased to be used as door prizes or raffle items*
 766 *(6) Non-employee/official expense*
 767 *(7) Alcoholic beverages*
 768 *(8) Any traffic fines*
 769 *(9) Entertainment expenses*

770
 771 *This list is not all-inclusive. The Finance Officer or County Manager shall approve or disapprove all*
 772 *other expense reimbursements not clearly defined in the Policy or those which have been*
 773 *questioned.*

Attachment: 2016-11-21 BOC Minutes Draft Ltr (1595 : 2016-11-21 BOC Minutes - Draft)

CAMDEN COUNTY BOARD OF COMMISSIONERS

Regular Meeting – November 21, 2016

774 **RESULT:** **ACCEPT AS PRESENTED [UNANIMOUS]**
 775 **MOVER:** Tom White, Commissioner
 776 **AYES:** McLain, Duckwall, Riggs, White
 777 **ABSENT:** Meiggs

778 **7. BOARD APPOINTMENTS**779 **A. WATERSHED ADVISORY COMMITTEES**

780 Commissioner Riggs made a motion to approve the Agriculture Advisory Boards members
 781 and Watershed Advisory Boards as presented by staff.

782 **RESULT:** **APPROVED AS PRESENTED [UNANIMOUS]**
 783 **MOVER:** Clayton Riggs, Commissioner
 784 **AYES:** McLain, Duckwall, Riggs, White
 785 **ABSENT:** Meiggs

786 **8. CONSENT AGENDA**

787 **RESULT:** **ACCEPT AS PRESENTED [UNANIMOUS]**
 788 **MOVER:** Tom White, Commissioner
 789 **AYES:** McLain, Duckwall, Riggs, White
 790 **ABSENT:** Meiggs

791 **A. 2016-11-07 BOC MINUTES – DRAFT**

792

793 **B. BUDGET AMENDMENT BA-007**

794 2016-17-BA007
 795 CAMDEN COUNTY BUDGET AMENDMENT
 796

797 BE IT ORDAINED by the Governing Board of the County of Camden, North Carolina that the following
 798 amendment is made to the annual budget ordinance for the fiscal year ending June 30, 2017.

799 Section 1. To amend the General Fund as follows:

ACCT NUMBER	DESCRIPTION OF ACCT	INCREASE	DECREASE
Revenues 10385510-402001	Donations	\$1,425	
Expenses 105100-551400	Fund Raiser Expended	\$1,425	

CAMDEN COUNTY BOARD OF COMMISSIONERS

Regular Meeting – November 21, 2016

800
 801 This Budget Amendment is made to increase revenue and expenditures for donations received.
 802 This will result in no change to the Contingency of the General Fund.

803 **C. SCHOOL BUDGET AMENDMENTS**

Code Number	Description of Code	Amount	
		Increase	Decrease
5100	Regular Instructional Programs		\$6,524.00
5200	Special Instructional Programs	\$2,936.00	
5300	Alternative Program & Services		\$18.00
5400	School Leadership Services	\$981.00	
5500	Co-Curricular Services		\$900.00
5800	Alternative Programs	\$165.00	
6100	Reg Curricular Prog Support	\$1,068.00	
6300	Alternative Prog. Support Serv	\$358.00	
6500	Operational Support Services	\$775.00	
6600	Financial & Human Resources	\$750.00	
6900	Policy, Ldrshp & Pub Relations	\$1,640.00	
7100	Reg Community Services	\$597.00	
Explanation:			
Total Appropriation in Current Budget			\$2,385,686.00
Amount of Increase / Decrease of Above Amendment			\$0.00
Total Appropriation in Current Amended Budget			\$2,385,686.00

804
 805

Code Number	Description of Code	Amount	
		Increase	Decrease
9100	Category I Projects		
Explanation:			
Total Appropriation in Current Budget			\$391,453.72
Amount of Increase / Decrease of Above Amendment			\$0.00
Total Appropriation in Current Amended Budget			\$391,453.72

CAMDEN COUNTY BOARD OF COMMISSIONERS

Regular Meeting – November 21, 2016

Code Number	Description of Code	Amount	
		Increase	Decrease
5100	Regular Instructional Programs		\$6,911.00
5200	Special Instructional Programs	\$1,386.00	
5300	Alternative Program & Services	\$4,356.00	
5400	School Leadership Services	\$73.00	
5800	Alternative Programs		\$1,555.00
6100	Reg Curricular Prog Support		\$1,776.00
6400	Technology Support Services	\$8,513.00	
6500	Operational Support Services		\$3,800.00
6900	Policy, Ldrshp & Pub Relations		\$286.00
Explanation:			
Total Appropriation in Current Budget			\$873,732.27
Amount of Increase / Decrease of Above Amendment			\$0.00
Total Appropriation in Current Amended Budget			\$873,732.27

806

807

808

809

810

811 **D. TAX COLLECTION REPORT - OCTOBER 2016**

812

Tax Collection Report

CAMDEN COUNTY BOARD OF COMMISSIONERS

Regular Meeting – November 21, 2016

813

Oct. 2016

Day	Amount	Amount	Name of Account	Deposits	Internet
3	19,255.90	21,170.34			
	18,159.52	16,178.45	\$1638.05 - Refund	74,764.21	
	19,271.56	10,313.69		29,585.25	
4	28,380.26		\$1.00 - Over	28,380.26	
5	31,488.16		\$298.92 - bad check	31,488.16	
	14,554.25	21,675.64	\$1.00 - Refund	36,229.89	
6	19,209.56	6,676.93		25,886.49	
	24,043.67		\$0.05 - Over	24,043.67	
7	25,674.90	21,599.84		47,274.74	
	17,878.51			17,878.51	
10	20,227.16	8,393.60		28,620.76	
	4,006.15		\$0.24 - Refund	4,006.15	
11	12,679.16		\$0.64 - Over	12,679.16	
	19,107.18	13,143.45		32,250.63	
12	11,668.92			11,668.92	
13	25,017.16			25,017.16	
	65,291.38	2,355.34	\$3,049.07 - Refund	67,646.72	
14	20,084.81	9,821.05	\$291.07 - Refund	29,905.86	
17	21,759.98			21,759.98	
	14,286.79	41,546.47	\$0.13 - Refund	55,833.26	
18	25,856.27		\$0.01 - Refund	25,856.27	
	9,494.76				9,494.76
19	6,126.71			6,126.71	
	9,707.89			9,707.89	
20	16,427.83			16,427.83	
21	26,391.99		\$7.20 - Refund	26,391.99	
24	25,212.83	9,428.34	\$0.14 - Refund	34,641.17	
25	8,688.40		\$2.43 - Refund	8,688.40	
26	20,210.70		\$0.61 - Refund	20,210.70	
27	29,646.20			29,646.20	
28	26,836.05			26,836.05	
	2,588.66				2,588.66
31	31,960.32		\$1.00 - Refund	31,960.32	
	20,070.58		\$29.67 - Refund	20,070.58	
	825.16				825.16
	687.18			687.18	
	\$692,776.51	\$182,303.14		\$862,171.07	\$12,908.58
	\$875,079.65			\$875,079.65	
	-\$11.00	PSN Check Fees			
	-\$5,020.62	Refund			
	\$1.69	Over			
	\$298.92	Shortage-Bad check			
	\$7.62	Tax Adjustment	Difference: Tax vs. Details		
	\$870,356.26				

814

815

816 **E. REFUNDS OVER \$100 – VTS**

Attachment: 2016-11-21 BOC Minutes Draft Ltr (1595 : 2016-11-21 BOC Minutes - Draft)

CAMDEN COUNTY BOARD OF COMMISSIONERS
Regular Meeting – November 21, 2016

Requested by: Sheriff Tony Pery
 Sell Dispose

Department: Sheriff's Office LESO Program

Item: Traffic Signal Light

Disposal Method: Gov Deals

Suggested Value: \$500.00

Reason for surplus: No longer useful to office, dead circuit board

Item Description
Portable stop light trailer



Manager Approval

Disposal Method: Gov Deals

Value: \$500.00

Comments:

Board Approval

Approved/Denied:

Date:

Final Disposition Date:

Method:

Amount:

Purchased by:

820

Requested by: Sheriff Tony Pery
 Sell Dispose

Department: Sheriff's Office LESO Program

Item: Golf Cart with Work bed

Disposal Method: Gov Deals

Suggested Value: \$1,500.00

Reason for surplus: Dead batteries and faulty wiring

Item Description
Golf Cart with work bed, two seater



Manager Approval

Disposal Method: Gov Deals

Value: \$1,500.00

Comments:

Board Approval

Approved/Denied:

Date:

Final Disposition Date:

Method:

Amount:

Purchased by:

821

822 G. DMV MONTHLY REPORT

823 STATE OF NORTH CAROLINA
824 COUNTY OF CAMDEN

825 TO: The Tax Administrator of Camden County January Ren. Due 2/15/17

CAMDEN COUNTY BOARD OF COMMISSIONERS

Regular Meeting – November 21, 2016

826 You are hereby authorized, empowered, and commanded to collect the taxes set forth in the tax
827 records filed in the office of the Tax Administrator and in the tax receipts herewith delivered to you,
828 in the amounts and from the taxpayers likewise therein set forth. Such taxes are hereby declared to
829 be a first lien upon personal property of the respective taxpayers in the County of Camden, and this
830 order shall be a full and sufficient authority to direct, require, and enable you to levy on and sell
831 personal property of such taxpayers for and on account thereof, in accordance with the law.

<i>SOUTH MILLS</i>	<i>COURTHOUSE</i>	<i>SHILOH</i>	<i>TOTAL</i>
<i>18,525.36</i>	<i>18249.67</i>	<i>9653.54</i>	<i>46428.57</i>

832
833 Witness my hand and official seal this 21st, day of November, 2016.

834 H. Volunteer Applications

835 9. COMMISSIONERS' REPORT

836 Commissioner Sandra Duckwall wanted to thank the citizens of Camden and the Board of
837 Commissioners for allowing her to serve. She commented that she has thouraly enjoyed
838 working with the Board and Staff.

839 10. COUNTY MANAGER'S REPORT

840 None

841

842 **RECESS**

843 At 7:33 P.M. Chairman McLain recessed the Commissioners meeting to enter into the South
844 Camden Water and Sewer District Board of Directors meeting.

845 **SOUTH CAMDEN WATER & SEWER DISTRICT**
846 **BOARD OF DIRECTORS**

847 **RECONVENE**

848 At 7:36 P.M. Chairman McLain reconvened the Board of Commissioners meeting

849 11. INFORMATION, REPORTS & MINUTES FROM OTHER AGENCIES

850 (The following informational items are kept on file in the office of the Clerk to the Board for public review)

851 A. Sales Tax Collections 16-17

852 B. Disaster Recovery Center - Individual Assistance Summary

CAMDEN COUNTY BOARD OF COMMISSIONERS

Regular Meeting – November 21, 2016

853 C. EMS REPORTS

854 D. COUNTY COMMISSIONER COMPLETES LEADERSHIP TRAINING

855

856 **12. OTHER MATTERS**

857 None

858 **13. ADJOURN**

859 Chairman McLain adjourned at 7:38 PM.

860

861

862 *Chairman Michael McLain*
863 *Camden County Board of Commissioners*

864

865 *ATTEST:*

866

867

868

869 *Angela L. Wooten*
870 *Clerk to the Board*

Attachment: 2016-11-21 BOC Minutes Draft Ltr (1595 : 2016-11-21 BOC Minutes - Draft)



CAMDENCOUNTY

new energy. new vision.

Board of Commissioners AGENDA ITEM SUMMARY SHEET

Consent Agenda

Item Number: 8.B
Meeting Date: March 06, 2017

Submitted By: Angela Wooten, Clerk to the Board
Administration
Prepared by: Angela Wooten

Item Title **2017-02-20 BOC Minutes - Draft**

Attachments: 2017-02-20 BOC Minutes - Draft Ltr (PDF)

Summary:

2017-02-20 BOC Minutes - Draft

Recommendation:

Review and Approve

CAMDEN COUNTY BOARD OF COMMISSIONERS

BOC - Regular Meeting – February 20, 2017

Camden County Board of Commissioners**BOC - Regular Meeting****February 20, 2017****6:30 PM****Historic Courtroom, Courthouse Complex****Camden, North Carolina****MINUTES**

The regular meeting of the Camden County Board of Commissioners was held on February 20, 2017 in the Historic Courtroom, Camden, North Carolina. The following Commissioners were present:

WELCOME & CALL TO ORDER

Vice Chairman Tom White called the meeting to order at 6:30 P.M.

Commissioners	Title	Status
Clayton Riggs	Chairman	Present
Tom White	Commissioner	Present
Garry Meiggs	Vice Chairman	Absent
Randy Krainiak	Commissioner	Present
Ross Munro	Commissioner	Present
Staff	Title	Status
Michael Brillhart	County Manager	Present
Angela Wooten	Clerk to the Board	Present
John Morrison	County Attorney	Present

ENTER CLOSED SESSION

At 6:33 P.M. Commissioner Ross Munro made a motion to go into closed session to discuss potential litigation.

RESULT:	PASSED [UNANIMOUS]
MOVER:	Ross Munro, Commissioner
AYES:	White, Krainiak, Munro
ABSENT:	Riggs, Meiggs

EXIT CLOSED SESSION

CAMDEN COUNTY BOARD OF COMMISSIONERS

Regular Meeting – February 20, 2017

23 *The Board of Commissioners came out of Closed Session at 7:01 P.M.*

24	RESULT:	PASSED [UNANIMOUS]
25	AYES:	White, Krainiak, Munro
26	ABSENT:	Riggs, Meiggs

27 **INVOCATION & PLEDGE OF ALLEGIANCE**

28 *Commissioner Ross Munro gave the invocation and Pledge of Allegiance.*

29 **1. PUBLIC COMMENTS**

30 *Penny Leary Smith of 289 North Highway 343 in Camden has come before the board with the*
 31 *following comments pertaining to her interest in serving as a member of Camden's Economic*
 32 *Development Commission*

- 34 • *Ms. Smith's volunteer application for the CEDC was approved several months ago by the*
 35 *Commissioners*
- 36 • *A copy of her biography was also submitted.*
- 37 • *She has experience on both State and Local boards and many accomplishments.*
- 38 • *She has been advised of an opening on the economic development board and*
 39 *respectfully requests their support.*

40 **2. CONSIDERATION OF AGENDA**

41 *Motion to approve the agenda as presented*

42	RESULT:	PASSED [UNANIMOUS]
43	MOVER:	Ross Munro, Commissioner
44	AYES:	White, Krainiak, Munro
45	ABSENT:	Riggs, Meiggs

46 **3. PRESENTATIONS**

47 **A. SENIOR TAR HEEL LEGISLATURE UPDATES BY GWEN WESCOTT**

48 *Camden County's Senior Tar Heel Legislature representative Mrs. Gwen Wescott gave the*
 49 *following updates:*

50
 51

CAMDEN COUNTY BOARD OF COMMISSIONERS

Regular Meeting – February 20, 2017

52 HomeMeds Medication Safety Program

- 53 • An evidence-based, in-home, medication review and intervention that includes a
- 54 computerized risk assessment and alert process, plus a pharmacist review and
- 55 recommendation for improvement
- 56 • A complement to other evidence-based programs that address patient readmission
- 57 reduction, health self-management, care transitions or caregiver support

59 NC Senior Tar Heel Legislature**60 2017 Legislative Priorities**

- 61 • Re-establish the Study Commission on Aging
- 62 • Increase HCCBG Funding
- 63 • Increase Funding for Senior Centers
- 64 • Sustain and Expand Project C.A.R.E.
- 65 • Strengthen and Fund North Carolina's Adult Protective Services Program (APS)
- 66 • Contact NCSTHL

69 NC Coalition on Aging**70 2017 Legislative Priorities**

- 71 • Increase the recurring state funding for the Home and Community Care Block Grant
- 72 (HCCBG) by \$7 million.
- 73 • Establish a joint legislative committee to examine issues pertaining to the state's
- 74 growing older adult population, including health care and financial security, and to make
- 75 recommendations on how the state can better support North Carolinians to age with
- 76 dignity.
- 77 • Increase state funding and support for adult protective services (APS) and public
- 78 guardianship services and conduct a comprehensive evaluation of these services.
- 79 • In order to better support direct care workers and help reduce worker turnover, invest in
- 80 Medicaid Personal Care Services (PCS) and the Community Alternatives Program for
- 81 Disabled Adults(CAP-DA) programs by increasing the reimbursement rate over a two
- 82 year period from \$13.88 per hour to the national average of \$18.82.
- 83 • Pass legislation that will support working family caregivers and help to keep them in the
- 84 workforce.
- 85

86
87 Dear Chairman:

88
89 I sincerely thank you for allowing me the privilege of representing the senior citizens of Camden
90 as their STHL delegate. I appreciate your faith in me and your cooperation with me, as I
91 attended regional and state STHL events.

CAMDEN COUNTY BOARD OF COMMISSIONERS

Regular Meeting – February 20, 2017

92

93 *The board selected me when I was sixty-two, now I am eighty. Therefore, it is time for a younger*
 94 *senior to represent Camden County senior citizens. I have tried to represent Camden*
 95 *respectfully, thoughtfully, intelligently and conservatively. I realized every wish, idea, want or*
 96 *request affected each- old or young-individual in Camden and in the state.*

97

98 *Again, with sincere gratitude for the opportunity to serve Camden's citizens, I offer my*
 99 *resignation as the STHL delegate effective February 2017.*

100

101 *Gwendolyn Wescott*

102 **B. MID-YEAR BUDGET PRESENTATION**

103 *Camden County's Finance Officer, Ms. Stephanie Humphries gave the MID-YEAR BUDGET*
 104 *REPORT JULY 1, 2016 THRU DECEMBER 31, 2016. A copy of this report is kept in the office of the*
 105 *Clerk for public review.*

106 *Motion to accept the Mid-Year Budget report as presented*

107 RESULT:	PASSED [UNANIMOUS]
108 MOVER:	Randy Krainiak, Commissioner
109 AYES:	White, Krainiak, Munro
110 ABSENT:	Riggs, Meiggs

111

112 **4. OLD BUSINESS**

113 *None*

114 **5. PUBLIC HEARINGS**

115 *None*

116 **6. NEW BUSINESS**

117 **A. HAZARD MITIGATION GRANT PROGRAM**
 118 **RESOLUTION NO. 2017-02-01**

119 *Christy Saunders of Emergency Management Agency*

120

CAMDEN COUNTY BOARD OF COMMISSIONERS

Regular Meeting – February 20, 2017

121 *County Manager Michael Brillhart announced that he just received a call from Ms. Saunders;*
 122 *she will be unable to attend due to an emergency.*

123

124 *Mr. Brillhart presented this item in her absence.*

125 *Mr. Brillhart advised that the North Carolina Division of Emergency Management (NCEM) s*
 126 *administering the FEMA based Hazard Mitigation Grant Program in light of the catastrophic*
 127 *impacts of Hurricane Matthew. With an adopted Hazard Mitigation Plan, Camden County*
 128 *(and its residents) is eligible to apply for applicable hazard mitigation funds.*

129

130 *In order to apply for program funds, the County Commissioners would need to: approve its*
 131 *participation in the program; become a grant sub recipient; and convene a "Town Meeting"*
 132 *for interested residents. Letters of interest must be received by NCEM by May 1, 2017.*

133

134

RESOLUTION No. 2017-02-01

135 ***A RESOLUTION AUTHORIZING THE CAMDEN COUNTY MANAGER TO ENTER INTO A SUB-***
 136 ***APPLICANT AGREEMENT BETWEEN CAMDEN COUNTY AND NORTH CAROLINA***
 137 ***DEPARTMENT OF PUBLIC SAFETY, DIVISION OF EMERGENCY MANAGEMENT TO***
 138 ***PARTICIPATE IN THE UNIFIED HAZARD MITIGATION ASSISTANCE PROGRAM.***

139

140 ***WHEREAS***, *the Federal Emergency Management Agency (FEMA) and the State of North*
 141 *Carolina, Department of Public Safety, Division of Emergency Management has Hazard*
 142 *Mitigation funds available to the jurisdictions of declared counties; and*

143 ***WHEREAS***, *the disaster, affected citizens of Camden County would greatly benefit from the*
 144 *acquisition and demolition, elevation, and reconstruction programs which are the top*
 145 *priorities in the Unified Hazard Mitigation Assistance Program (UHMA); and*

146

147 ***WHEREAS***, *storm water management, wind retrofits and purchasing of commercial*
 148 *properties are the second tier of priority; and*

149

150 ***WHEREAS***, *the devastation of Hurricane Matthew has resulted in the largest Hazard*
 151 *Mitigation Grant Program since Hurricane Floyd; with fund availability in excess of \$100*
 152 *million;*

153

154 ***NOW, THEREFORE, BE IT RESOLVED*** *by the Camden County Board of Commissioners that*
 155 *the Camden County Manager is authorized to apply for grant funds through the Unified*
 156 *Hazard Mitigation Assistance Program and as sub-applicant work closely with the North*
 157 *Carolina Division of Emergency Management to identify eligible and cost effective projects for*
 158 *this long-term program designed to protect lives and properties from future disaster.*

159

160 ***ADOPTED*** *this 20th day of February, 2017.*

CAMDEN COUNTY BOARD OF COMMISSIONERS

Regular Meeting – February 20, 2017

161 **RESULT:** **ADOPTED [UNANIMOUS]**
 162 **MOVER:** Randy Krainiak, Commissioner
 163 **AYES:** White, Krainiak, Munro
 164 **ABSENT:** Riggs, Meiggs

165

166 **B. MONTHLY TAX REPORT – DECEMBER 2016**

167

168

169

170

171

MONTHLY REPORT OF THE TAX ADMINISTRATOR TO THE
 CAMDEN COUNTY BOARD OF COMMISSIONERS
 OUTSTANDING TAX DELINQUENCIES BY YEAR

<u>YEAR</u>	<u>REAL PROPERTY</u>	<u>PERSONAL PROPERTY</u>
2015	88,613.04	5,022.63
2014	42,116.98	4,066.68
2013	18,193.85	6,819.16
2012	12,551.01	9,389.34
2011	8,839.70	7,542.93
2010	6,613.27	5,116.63
2009	4,651.99	4,831.51
2008	4,052.78	5,231.68
2007	4,010.88	7,060.31
2006	1,544.50	12,572.19
TOTAL REAL PROPERTY TAX UNCOLLECTED		191,188.00
TOTAL PERSONAL PROPERTY UNCOLLECTED		67,653.06
TEN YEAR PERCENTAGE COLLECTION RATE		99.62%
COLLECTION FOR 2016 vs. 2015		13,141.77 vs. 9,078.88

172

LAST 3 YEARS PERCENTAGE COLLECTION RATE

2015	98.59%
2014	99.32%
2013	99.64%

173

CAMDEN COUNTY BOARD OF COMMISSIONERS

Regular Meeting – February 20, 2017

EFFORTS AT COLLECTION IN THE LAST 30 DAYSENDING December **2016****BY TAX ADMINISTRATOR**

<u>11</u>	NUMBER DELINQUENCY NOTICES SENT
<u>6</u>	FOLLOWUP REQUESTS FOR PAYMENT SENT
<u>6</u>	NUMBER OF WAGE GARNISHMENTS ISSUED
<u>4</u>	NUMBER OF BANK GARNISHMENTS ISSUED
<u>12</u>	NUMBER OF PERSONAL PHONE CALLS MADE BY TAX ADMINISTRATOR TO DELINQUENT TAXPAYER
<u>0</u>	NUMBER OF PERSONAL VISITS CONDUCTED (COUNTY OFFICES)
<u>0</u>	PAYMENT AGREEMENTS PREPARED UNDER AUTHORITY OF TAX ADMINISTRATOR
<u>0</u>	NUMBER OF PAYMENT AGREEMENTS RECOMMENDED TO COUNTY ATTORNEY
<u>0</u>	NUMBER OF CASES TURNED OVER TO COUNTY ATTORNEY FOR COLLECTION (I.D. AND STATUS)
<u>0</u>	REQUEST FOR EXECUTION FILES WITH CLERK OF COURTS
<u>0</u>	NUMBER OF JUDGMENTS FILED

174

175 **RESULT:** APPROVED AS PRESENTED [UNANIMOUS]
 176 **MOVER:** Ross Munro, Commissioner
 177 **AYES:** White, Krainiak, Munro
 178 **ABSENT:** Riggs, Meiggs

179 **7. BOARD APPOINTMENTS**180 **A. PLANNING BOARD**

181 Appoint Mr. Steven Bradshaw to serve the Planning Board for a term of 3 years to expire on
 182 2/19/2020.

183 **RESULT:** APPROVED AS PRESENTED [UNANIMOUS]
 184 **MOVER:** Randy Krainiak, Commissioner
 185 **AYES:** White, Krainiak, Munro
 186 **ABSENT:** Riggs, Meiggs

187 **B. AREA AGENCY ON AGING**
 188 **REGIONAL ADVISORY COUNCIL VOLUNTEER APPLICATION**

Attachment: 2017-02-20 BOC Minutes - Draft Ltr (1596 : 2017-02-20 BOC Minutes - Draft)

CAMDEN COUNTY BOARD OF COMMISSIONERS

Regular Meeting – February 20, 2017

189 Appoint Jasmine Wilson to the Area Agency on Aging - Regional Advisory Council

190 **RESULT:** APPROVED AS PRESENTED [UNANIMOUS]
 191 **MOVER:** Ross Munro, Commissioner
 192 **AYES:** White, Krainiak, Munro
 193 **ABSENT:** Riggs, Meiggs

194 **C. HOME AND COMMUNITY BLOCK GRANT**

195 Appoint Rickey Wilson to the Home and Community Care Block Grant Committee for a 2
 196 year term to expire 2/19/2019.

197 **RESULT:** APPROVED AS PRESENTED [UNANIMOUS]
 198 **AYES:** White, Krainiak, Munro
 199 **ABSENT:** Riggs, Meiggs

200 **8. CONSENT AGENDA**

201 County Manager Michael Brillhart requested the following amendments:

202

203 * Consent Agenda

204 *Item 8.R - Set Public Hearing - Special Use Permit Preliminary Plat Mill Run*

205 o **Change** the recommended Public Hearing Date from March 6th to April 3rd,
 206 2017

207 Commissioner Randy Krainiak made a motion to approve the Consent Agenda as amended.

208 **RESULT:** ACCEPT AS AMENDED [UNANIMOUS]
 209 **MOVER:** Randy Krainiak, Commissioner
 210 **AYES:** White, Krainiak, Munro
 211 **ABSENT:** Riggs, Meiggs

212

CAMDEN COUNTY BOARD OF COMMISSIONERS

Regular Meeting – February 20, 2017

213

214 **A. BUDGET AMENDMENTS**

215

2016-17 BA013			
Section 1. To amend the South Mills Volunteer Fire Department Fund as follows:			
ACCT NUMBER	DESCRIPTION OF ACCT	AMOUNT	
		INCREASE	DECREASE
Revenues			
41	Fund Balance Appropriated	\$12,000	
Expenses			
41	Equipment Maintenance	\$12,000	
This Budget Amendment is made appropriate funds for Pump Maintenance.			

216

2016-17 BA013			
Section 1. To amend the General Fund as follows:			
ACCT NUMBER	DESCRIPTION OF ACCT	AMOUNT	
		INCREASE	DECREASE
Revenues			
10330611-434898	Grant Revenue	\$5,000	
Expenses			
106110-533000	Supplies	\$5,000	
This Budget Amendment is made appropriate funds for Library grant received.			

217

2016-17 BA014			
Section 1. To amend the General Fund as follows:			
ACCT NUMBER	DESCRIPTION OF ACCT	AMOUNT	
		INCREASE	DECREASE
Revenues			
10330670-434810	Grant Revenue	\$5,354	
Expenses			
106700-533100	Grant Expense	\$5,354	
This Budget Amendment is made appropriate funds for Soil & Water grant received.			

218

219 **B. CCS BUDGET AMENDMENTS**

Attachment: 2017-02-20 BOC Minutes - Draft Ltr (1596 : 2017-02-20 BOC Minutes - Draft)

CAMDEN COUNTY BOARD OF COMMISSIONERS

Regular Meeting – February 20, 2017

Code Number	Description of Code	Amount	
		Increase	Decrease
5100	Regular Instructional Programs	25,425.00	
5200	Special Instructional Programs	2,715.00	
6400	Technology Support Services	2,161.00	
6500	Operational Support Services		27385.00
6800	System-wide Student Services	379.00	
6900	Policy, Leadership, Pub Relation		201.00
Explanation:			
Total Appropriation in Current Budget		\$	873,732.27
Amount of Increase/Decrease of Above Amendment			3,094.00
Total Appropriation in Current Amended Budget		\$	876,826.27

220

Code Number	Description of Code	Amount	
		Increase	Decrease
5200	Special Instructional Programs		27.00
5800	Alternative Programs		11,140.00
6500	Operational Support Services	27.00	
6900	Policy, Ldrshp, & Pub Relations	11,140.00	
Explanation:			
Total Appropriation in Current Budget		\$	2,385,686.00
Amount of Increase/Decrease of Above Amendment			.00
Total Appropriation in Current Amended Budget		\$	2,385,686.00

221

222 **C. DMV MONTHLY REPORT MARCH RENEWALS**

223 **STATE OF NORTH CAROLINA**

224 **COUNTY OF CAMDEN**

225

226 *TO: The Tax Administrator of Camden County March Ren. Due 4/15/17*

227

Attachment: 2017-02-20 BOC Minutes - Draft Ltr (1596 : 2017-02-20 BOC Minutes - Draft)

CAMDEN COUNTY BOARD OF COMMISSIONERS

Regular Meeting – February 20, 2017

228 You are hereby authorized, empowered, and commanded to collect the taxes set forth in the tax
229 records filed in the office of the Tax Administrator and in the tax receipts herewith delivered to
230 you, in the amounts and from the taxpayers likewise therein set forth. Such taxes are hereby
231 declared to be a first lien upon personal property of the respective taxpayers in the County of
232 Camden, and this order shall be a full and sufficient authority to direct, require, and enable you
233 to levy on and sell personal property of such taxpayers for and on account thereof, in
234 accordance with the law.

235
236

SOUTH MILLS	COURTHOUSE	SHILOH	TOTAL
20,933.86	2,2059.05	12,212.10	55,205.01

237

238 D. REFUNDS OVER \$100.00

ACS Tax System 1/13/17 8:56:36 REFUNDS OVER \$100.00 CAMDEN COUNTY

Refunds to be Issued by Finance Office

Refund\$	Remit To:	Reference:	Drawer/Transaction Info:
528.92	CORELOGIC RETS - REFUND DEPT. P.O. BOX 961250 FORT WORTH TX 761619858	2016 R 01-7998-00-53-5592.0000 OVERPAYMENT - R-85155-16	20161230 2 230664
2,572.33	CORELOGIC RETS - REFUND DEPT. P.O. BOX 961250 FORT WORTH TX 761619858	2016 R 02 8943 01 26 5768 0000 OVERPAYMENT - R-97421-16	20161230 2 230741
37.67	CORELOGIC RETS - REFUND DEPT. P.O. BOX 961250 FORT WORTH TX 761619858	2016 R 03 8952 01 49 5675.0000 OVERPAYMENT - R-99486-16	20161230 2 230807
1,700.40	CORELOGIC RETS - REFUND DEPT. P.O. BOX 961250 FORT WORTH TX 761619858	2016 R 02 8943 01 46 5738 0000 OVERPAYMENT - R-98698/98697-16	20170103 2 230929
395.53	CORELOGIC RETS - REFUND DEPT. P.O. BOX 961250 FORT WORTH TX 761619858	2016 R 02 8935 02 89 7250 0000 OVERPAYMENT-R-98165-R-97851-16	20170104 2 231057
1,274.59	CORELOGIC RETS - REFUND DEPT. P.O. BOX 961250 FORT WORTH TX 761619858	2016 R 01 7979 00 26 5797 0000 OVERPAYMENT - R-94720-16	20170104 2 231119
1,731.12	CORELOGIC RETS-REFUND DEPT. P.O. BOX 961250 FORT WORTH TX 761619858	2016 R 01-7080-00-16-2554.0000 OVERPAY-R97452,R99402,R95897	20170105 3 231154
1,088.82	M & M ASSOCIATES LIMITED 7461 NORTH SHORE ROAD NORFOLK VA 23505	2016 R 01-7997-00-75-8426.0000 overpayment	20170105 4 231218
106.46	MEG INVESTMENTS, LLC P.O. BOX 456 MOYOCK NC 27958	2016 R 01-8001-00-44-2269.0000 overpayment	20170110 1 231352

Handwritten bracket and number 7 pointing to the first two rows of the refund table.

7 * Fire tax only being refunded due to Company putting a stop payment on the check for \$2,572.33.

239
240

Attachment: 2017-02-20 BOC Minutes - Draft Ltr (1596 : 2017-02-20 BOC Minutes - Draft)

CAMDEN COUNTY BOARD OF COMMISSIONERS

Regular Meeting – February 20, 2017

241 **E. REFUNDS OVER \$100.00**

Refunds Over \$100.00

ACS Tax System 12/28/16 16:21:16 CAMDEN COUNTY

Refunds to be Issued by Finance Office

Refund\$	Remit To:	Reference:	Drawer/Transaction Info:
143.32	BLACKWELL, MINNIE 40 GRAHAM STREET STRATFORD CT 06615	2016 R 03-8962-00-73-3144.0000 value change	20161202 99 229480
795.98	CORELOGIC RETS - REFIMD DEPT. P.O. BOX 961250 SHILOH NC 27974	2016 R 03-8961 00 68 3102.0000	20161222 3 230196
155.74	FIRST AMERICAN MORTGAGE SERV. SOLANA BLVD., BLDG. 6 STE. 6200 WESTLAKE TX 76262	2016 R 03-8963-00-00-3982.0000	20161110 1 228898 overpayment 2016 realestate
100.00	JOHNSON-MCCOY, CLARETTA 6038 NORTH 13TH STREET PHILADELPHIA PA 19141	2016 R 01-7998-00-56-2041.0000	20161109 1 228891 overpayment on realestate
310.50	JONES, EVAINIA HUNT 233 LAKE ROAD CAMDEN NC 27921	2015 R 01-8908-00-51-3617.0000	20161228 99 230448 exclusion should be on this pa
310.50	JONES, EVAINIA HUNT 233 LAKE ROAD CAMDEN NC 27921	2016 R 01-8908-00-51-3617.0000	20161228 99 230450 apply to 88237/15 & 95383/2016
196.65	SEABOARD DEVELOPMENT ALLIANCE 1073 BULLARD COURT RALEIGH NC 27615	2016 R 03-8965-00-25-2074.0000	20161130 1 229400 overpayment record#100888
117.29	STAPLES, ABNER WAYNE 1381 S HIGHWAY 343 SHILOH NC 27974	2016 R 03-8973-00-25-3231.0000	20161202 99 229477 value adjustment
1,490.76	WELLS FARGO REAL ESTATE TAX 1 HOME CAMPUS SOUTH MILLS NC 27976	2016 R 01-7080-00-18-3211.0000	20161115 2 228984
3,620.74	Total Refunds		***

242

243 **F. PICK UPS, RELEASES, AND REFUNDS**

NAME	REASON	TYPE NO.
Angelia Leigh Williams, ETAL	\$361.76 Pick-Up - Rolled back taxes	Pick-Up/19807 R-82353-14 R-89472-15 R-96615-16
Alice Bartlett Sawyer	\$122.54 Adjustment value correction	Pick-Up/19805 R-98511-16
Stanford & Evania Jones	\$310.50 Adjustment - exclusion on wrong property	Pick-Up/19804 R-88237-15
Stanford & Evania Jones	\$310.50 Adjustment - exclusion on wrong property	Pick-Up/19803 R-95383-16
Stanford & Evania Jones	\$310.50 Adjustment - exclusion on wrong property	Pick-Up/19802 R-95373-15
Evania Hunt Jones	\$310.50 Adjustment - exclusion on wrong property	Pick-Up/19801 R-95373-16
Gus Woodrow McPherson	\$987.20 Adjustment - corrected value	Pick-Up/19800 R-95653-16
C & L Concrete Woks, Inc.	\$257.76 Released - value corrected	PickUp/19767 R-97046-16

Attachment: 2017-02-20 BOC Minutes - Draft Ltr (1596 : 2017-02-20 BOC Minutes - Draft)

CAMDEN COUNTY BOARD OF COMMISSIONERS
 Regular Meeting – February 20, 2017

Tax Collection Report
 DEC. 2016

Day	Amount	Amount	Name of Account	Deposits	Internet
1	52,502.15		\$0.07 - Over	52,502.15	
2	27,386.41		\$377.62 - Refund- Drw.99	27,386.41	
5	36,048.45	25,396.50	\$15.49-Refund/\$0.64 Over	61,444.95	
6	11,780.37			11,780.37	
7	36,021.84			36,021.84	
8	137,969.09	44,276.64	\$10.55-Refund/\$0.02-Over	182,245.73	
9	30,999.77			30,999.77	
12	43,983.95		\$106.65 - Refund	43,983.95	
13	63,190.14	27,231.29	\$ 29.80 - Refund	80,421.43	
14	165.77		\$ 36.74 - Refund		165.77
	22,028.12		\$ 0.40 - Refund	22,028.12	
15	24,383.81	18,575.28		42,959.09	
16	42,557.14		\$2.00 - Refund	42,557.14	
19	19,852.98			19,852.98	
20	115,217.15	18,465.44	\$20.00 - Refund	133,682.59	
21	42,521.98	25,919.32		68,441.30	
22	35,469.26			35,469.26	
	30,683.93		\$19.71 - Refund	30,683.93	
	126,603.59		\$795.98 - Refund	126,603.59	
28	27,166.79	86,643.94		113,810.73	
	439.89			439.89	
	50,315.65	48,702.45	\$716.67 - Refund		
	86,017.85		\$20.00 - Refund	185,035.95	
29	47,141.90	41,980.75			
	61,773.74		\$.01 - Refund	150,896.39	
	56,470.22			56,470.22	
	29,839.11			29,839.11	
	14,025.06				14,025.06
30	31,605.40	75,026.45	\$0.04 - Refund		
	55,929.66	6,553.44	\$0.27 - Over	169,114.95	
	39,305.44	1,869.23	\$1.16 - Refund	41,174.67	
	342,689.49	35,691.32	\$4,855.47 - Refund	378,380.81	
	7,798.51				7,798.51
	27,381.64			27,381.64	
	\$1,767,266.25	\$456,332.05		\$2,201,608.96	\$21,989.34
	\$2,223,598.30			\$2,223,598.30	
	-\$10.00				
	-\$7,008.29	Refund			
	\$1.00	Over			
	\$0.00	Shortage			
	\$0.00				
	\$2,216,581.01				

249
250

Attachment: 2017-02-20 BOC Minutes - Draft Ltr (1596 : 2017-02-20 BOC Minutes - Draft)

CAMDEN COUNTY BOARD OF COMMISSIONERS

Regular Meeting – February 20, 2017

251

H. VOLUNTEER APPLICATION - GREG STEWART

253

254

Name: Gregory A. Stewart

Mailing Address: 134 Pudding Ridge Rd.

Township you live in: South Mills

Telephone (home): 852-548-2226 (business): _____

Email address: ga.stewart@yahoo.com

Are you a registered voter? Yes No

Have you ever been convicted of a felony? Yes No

Please identify any talent, interest, skill, experience or educational preparation which might be helpful to a board or commission: Business, public relations, government,

Boards or Commissions upon which you are interested in serving: _____

As a member of a Board or Commission, you will be expected to attend at least 75% of the meetings. Please note the by-laws of some Boards and Commissions limit the number of terms served. This application is a notification of your interest to serve on a Board or Commission to be considered by the Board of Commissioners when a vacancy occurs. Thanks for your interest in Camden County Government.

Signature: [Signature] Date: 1/10/2017

255

256

Attachment: 2017-02-20 BOC Minutes - Draft Ltr (1596 : 2017-02-20 BOC Minutes - Draft)

CAMDEN COUNTY BOARD OF COMMISSIONERS

Regular Meeting – February 20, 2017

257

I. VOLUNTEER APPLICATION - RICKEY WILSON

259

Name: Rickey Wilson
 Mailing Address: 489 Lambs Rd
 Township you live in: Camden
 Telephone (home): 334-1555 (business): 338-5018
 Email address: RSWLSW4@yahoo.com

Are you a registered voter? Yes No

Have you ever been convicted of a felony? Yes No

Please identify any talent, interest, skill, experience or educational preparation which might be helpful to a board or commission: 12 year member of ABC Board Education, member Sawyer Creek Church,

Boards or Commissions upon which you are interested in serving: Senior Board (advisory) Board of Adjustment, ABC Board

As a member of a Board or Commission, you will be expected to attend at least 75% of the meetings. Please note the by-laws of some Boards and Commissions limit the number of terms served. This application is a notification of your interest to serve on a Board or Commission to be considered by the Board of Commissioners when a vacancy occurs. Thanks for your interest in Camden County Government

Signature: [Handwritten Signature] Date: 12-10-16

260

261

Attachment: 2017-02-20 BOC Minutes - Draft Ltr (1596 : 2017-02-20 BOC Minutes - Draft)

CAMDEN COUNTY BOARD OF COMMISSIONERS

Regular Meeting – February 20, 2017

262 J. 2017 AUDIT CONTRACTS

LGC-205 (Rev. 2017)

CONTRACT TO AUDIT ACCOUNTS

Of Camden County Tourist Development Authority
Primary Governmental Unit

Discretely Presented Component Unit (DPCU) if applicable

On this 22nd day of December, 2016

Auditor: Thompson, Price, Scott, Adams & Co., P.A. Auditor Mailing Address: 4504 Clearstar Dr., Suite 103
Wilmington, NC 28403 Hereinafter referred to as The Auditor

and Board (Governing Board(s)) of Camden County Tourist Development Authority
(Primary Government)

and : hereinafter referred to as the Governmental Unit(s), agree as follows:
(Discretely Presented Component Unit)

1. The Auditor shall audit all statements and disclosures required by generally accepted accounting principles (GAAP) and additional required legal statements and disclosures of all funds and/or divisions of the Governmental Unit (s) for the period beginning July 1, 2015, and ending June 30, 2017. The non-major combining, and individual fund statements and schedules shall be subjected to the auditing procedures applied in the audit of the basic financial statements and an opinion will be rendered in relation to (as applicable) the governmental activities, the business-type activities, the aggregate DPCUs, each major governmental and enterprise fund, and the aggregate remaining fund information (non-major government and enterprise funds, the internal service fund type, and the fiduciary fund types).

2. At a minimum, the Auditor shall conduct his/her audit and render his/her report in accordance with generally accepted auditing standards. The Auditor shall perform the audit in accordance with Government Auditing Standards if required by the State Single Audit Implementation Act, as codified in G.S. 159-34. If required by OMB Uniform Administration Requirements, Cost Principles, and Audit Requirements for Federal Awards, (Uniform Guidance) and the State Single Audit Implementation Act, the Auditor shall perform a Single Audit. This audit and all associated audit documentation may be subject to review by Federal and State agencies in accordance with Federal and State laws, including the staffs of the Office of State Auditor (OSA) and the Local Government Commission (LGC). If the audit and auditor communication are found in this review to be substandard, the results of the review may be forwarded to the North Carolina State Board of CPA Examiners (NC CPA Board).

County and Multi-County Health Departments: The Office of State Auditor will designate certain programs that have eligibility requirements to be considered major programs in accordance with OMB Uniform Guidance for the State of North Carolina. The LGC will notify the auditor and the County and Multi-Health Department of these programs. A County or a Multi-County Health Department may be selected to audit any of these programs as major.

3. If an entity is determined to be a component of another government as defined by the group audit standards - the entity's auditor will make a good faith effort to comply in a timely manner with the requests of the group auditor in accordance with AU-6 §600.41 - §600.42.

4. This contract contemplates an unqualified opinion being rendered. The audit shall include such tests of the accounting records and such other auditing procedures as are considered by the Auditor to be necessary in the circumstances. Any limitations or restrictions in scope which would lead to a qualification should be fully explained in an attachment to this contract.

5. If this audit engagement is subject to the standards for audit as defined in Government Auditing Standards, 2011 revisions, issued by the Comptroller General of the United States, then by accepting this engagement, the Auditor warrants that he has met the requirements for a peer review and continuing education as specified in Government

263

Attachment: 2017-02-20 BOC Minutes - Draft Ltr (1596 : 2017-02-20 BOC Minutes - Draft)

CAMDEN COUNTY BOARD OF COMMISSIONERS

Regular Meeting – February 20, 2017

Contract to Audit Accounts (cont.)

Camden County Tourist Development Authority

Primary Governmental Unit

Discretely Presented Component Units (DPCU) if applicable

Auditing Standards. The Auditor agrees to provide a copy of their most recent peer review report regardless of the date of the prior peer review report to the Governmental Unit and the Secretary of the LGC prior to the execution of the audit contract (See Item 22). If the audit firm received a peer review rating other than pass, the Auditor shall not contract with the Governmental Unit without first contacting the Secretary of the LGC for a peer review analysis that may result in additional contractual requirements.

If the audit engagement is not subject to Government Accounting Standards or if financial statements are not prepared in accordance with GAAP and fail to include all disclosures required by GAAP, the Auditor shall provide an explanation as to why in an attachment.

6. It is agreed that time is of the essence in this contract. All audits are to be performed and the report of audit submitted to the State and Local Government Finance Division (SLGFD) within four months of fiscal year end. Audit report is due on: October 31, 2017. If it becomes necessary to amend this due date or the audit fee, an amended contract along with a written explanation of the delay must be submitted to the secretary of the LGC for approval.
7. It is agreed that generally accepted auditing standards include a review of the Governmental Unit's systems of internal control and accounting as same relate to accountability of funds and adherence to budget and law requirements applicable thereto; that the Auditor will make a written report, which may or may not be a part of the written report of audit, to the Governing Board setting forth his findings, together with his recommendations for improvement. That written report must include all matters defined as "significant deficiencies and material weaknesses" in AU-C 265 of the *AICPA Professional Standards (Clarified)*. The Auditor shall file a copy of that report with the Secretary of the LGC.
8. All local government and public authority contracts for audit or audit-related work require the approval of the Secretary of the LGC. This includes annual or special audits, agreed upon procedures related to internal controls, bookkeeping or other assistance necessary to prepare the Governmental Unit's records for audit, financial statement preparation, any finance-related investigations, or any other audit-related work in the State of North Carolina. **Invoices for services rendered under these contracts shall not be paid by the Governmental Unit until the invoice has been approved by the Secretary of the LGC.** (This also includes any progress billings.) [G.S. 159-34 and 115C-447] All invoices for Audit work must be submitted by email in PDF format to the Secretary of the LGC for approval. The invoices must be sent via upload through the current portal address: <http://nctreasurer.slgfd.leapfile.net>. Subject line should read "Invoice – [Unit Name]. The PDF invoice marked 'approved' with approval date will be returned by email to the Auditor to present to the Governmental Unit for payment. Approval is not required on contracts and invoices for system improvements and similar services of a non-auditing nature.
9. In consideration of the satisfactory performance of the provisions of this contract, the Primary Governmental Unit shall pay to the Auditor, upon approval by the Secretary of the LGC, the fee, which includes any cost the Auditor may incur from work paper or peer reviews or any other quality assurance program required by third parties (Federal and State grantor and oversight agencies or other organizations) as required under the Federal and State Single Audit Acts. (Note: Fees listed on signature pages.)
10. If the Governmental Unit has outstanding revenue bonds, the Auditor shall include documentation either in the notes to the audited financial statements or as a separate report submitted to the SLGFD along with the audit report, a calculation demonstrating compliance with the revenue bond rate covenant. Additionally, the Auditor should be aware that any other bond compliance statements or additional reports required in the authorizing bond documents need to be submitted to the SLGFD simultaneously with the Governmental Unit's audited financial statements unless otherwise specified in the bond documents.

Page 2 of 8

264

Attachment: 2017-02-20 BOC Minutes - Draft Ltr (1596 : 2017-02-20 BOC Minutes - Draft)

CAMDEN COUNTY BOARD OF COMMISSIONERS

Regular Meeting – February 20, 2017

Contract to Audit Accounts (cont.)

Camden County Tourist Development Authority

Primary Governmental Unit

Discretely Presented Component Units (DPCU) if applicable

11. After completing the audit, the Auditor shall submit to the Governing Board a written report of audit. This report shall include, but not be limited to, the following information: (a) Management's Discussion and Analysis, (b) the financial statements and notes of the Governmental Unit and all of its component units prepared in accordance with GAAP, (c) supplementary information requested by the client or required for full disclosure under the law, and (d) the Auditor's opinion on the material presented. The Auditor shall furnish the required number of copies of the report of audit to the Governing Board as soon as practical after the close of the accounting period.
12. If the audit firm is required by the NC CPA Board or the Secretary of the LGC to have a pre-issuance review of their audit work, there must be a statement added to the engagement letter specifying the pre-issuance review including a statement that the Governmental Unit will not be billed for the pre-issuance review. The pre-issuance review must be performed prior to the completed audit being submitted to the LGC. The pre-issuance report must accompany the audit report upon submission to the LGC.
13. The Auditor shall electronically submit the report of audit to the LGC as a text-based PDF file when (or prior to) submitting the invoice for services rendered. The report of audit, as filed with the Secretary of the LGC, becomes a matter of public record for inspection, review and copy in the offices of the SLOFD by any interested parties. Any subsequent revisions to these reports must be sent to the Secretary of the LGC. These audited financial statements, excluding the Auditors' opinion, may be used in the preparation of official statements for debt offerings, by municipal bond rating services to fulfill secondary market disclosure requirements of the Securities and Exchange Commission and other lawful purposes of the Governmental Unit without subsequent consent of the Auditor. If it is determined by the LGC that corrections need to be made to the Governmental Unit's financial statements, they should be provided within three days of notification unless another time frame is agreed to by the LGC.

If the OSA designates certain programs to be audited as major programs, as discussed in item #2, a turnaround document and a representation letter addressed to the OSA shall be submitted to the LGC.

The LGC's process for submitting contracts, audit reports and invoices is subject to change. Auditors should use the submission process in effect at the time of submission. The most current instructions will be found on our website: <https://www.nctreasurer.com/slg/Pages/Audit-Forms-and-Resources.aspx>.

14. Should circumstances disclosed by the audit call for a more detailed investigation by the Auditor than necessary under ordinary circumstances, the Auditor shall inform the Governing Board in writing of the need for such additional investigation and the additional compensation required therefore. Upon approval by the Secretary of the LGC, this contract may be varied or changed to include the increased time and/or compensation as may be agreed upon by the Governing Board and the Auditor.
15. If an approved contract needs to be varied or changed for any reason, the change must be made in writing, on the Amended LGC-205 contract form and pre-audited if the change includes a change in audit fee. This amended contract needs to be completed in full, including a written explanation of the change, signed and dated by all original parties to the contract, and then must be submitted through the audit contract portal to the Secretary of the LGC for approval. The portal address to upload your amended contract is <http://nctreasurer.slgfd.com/file.net>. No change shall be effective unless approved by the Secretary of the LGC, the Governing Board, and the Auditor.
16. A copy of the engagement letter, issued by the Auditor and signed by both the Auditor and the Governmental Unit should be attached to the contract, and by reference here becomes part of the contract. In case of conflict between the terms of the engagement letter and the terms of this contract, the terms of this contract will control. Engagement letter terms that conflict with the contract are deemed to be void unless the conflicting terms of this contract are specifically deleted in Item #25 of this contract. Engagement letters containing indemnification clauses will not be approved by the LGC.

Page 3 of 8

265

Attachment: 2017-02-20 BOC Minutes - Draft Ltr (1596 : 2017-02-20 BOC Minutes - Draft)

CAMDEN COUNTY BOARD OF COMMISSIONERS

Regular Meeting – February 20, 2017

Contract to Audit Accounts (cont.) Camden County Tourist Development Authority
Primary Governmental Unit

 Discretely presented component units if applicable

17. Special provisions should be limited. Please list any special provisions in an attachment.
18. A separate contract should not be made for each division to be audited or report to be submitted. If a DPCU is subject to the audit requirements detailed in the Local Government Budget and Fiscal Control Act and a separate audit report is issued, a separate audit contract is required. If a separate report is not to be issued and the DPCU is included in the primary government audit, the DPCU must be named along with the parent government on this audit contract. Signatures from the DPCU Board chairman and finance officer also must be included on this contract.
19. The contract must be executed, pre-audited, physically signed by all parties including Governmental Unit and Auditor signatures and submitted in PDF format to the Secretary of the LGC. The current portal address to upload your contractual documents is <http://nctreasurer.slgfd.leapfile.net>. Electronic signatures are not accepted at this time. Included with this contract are instructions to submit contracts and invoices for approval as of November 2016. These instructions are subject to change. Please check the NC Treasurer's web site at <https://www.nctreasurer.com/slg/Pages/Audit-Forms-and-Resources.aspx> for the most recent instructions.
20. The contract is not valid until it is approved by the LGC Secretary. The staff of the LGC shall notify the Governmental Unit and Auditor of contract approval by email. **The audit should not be started before the contract is approved.**
21. There are no other agreements between the parties hereto and no other agreements relative hereto that shall be enforceable unless entered into in accordance with the procedure set out herein and approved by the Secretary of the LGC.
22. **E-Verify.** Auditor **shall comply** with the requirements of NCGS Chapter 64 Article 2. Further, if Auditor utilizes any subcontractor(s), Auditor **shall require** such subcontractor(s) to comply with the requirements of NCGS Chapter 64, Article 2.
23. Contractor hereby certifies that Contractor, and all subcontractors, are not on the Iran Final Divestment List ("List") created by the North Carolina State Treasurer pursuant to N.C.G.S. 147-86.58. Contractor shall not utilize any subcontractor that is identified on the List.
25. All of the above paragraphs are understood and shall apply to this contract, except the following numbered paragraphs shall be deleted: (See Item 16 for clarification).

266
267

Attachment: 2017-02-20 BOC Minutes - Draft Ltr (1596 : 2017-02-20 BOC Minutes - Draft)

CAMDEN COUNTY BOARD OF COMMISSIONERS

Regular Meeting – February 20, 2017

LGC-205 (Rev. 2017)

CONTRACT TO AUDIT ACCOUNTS

Of Camden County
Primary Governmental Unit

Discretely Presented Component Unit (DPCU) if applicable

On this 16th day of December, 2016

Auditor: Thompson, Price, Scott, Adams & Co., P.A. Auditor Mailing Address: 4024 Cleander Dr., Suite 103
Wilmington, NC 28403 Hereinafter referred to as The Auditor

and Board of Commissioner (Governing Board(s)) of Camden County
(Primary Government)

and _____ : hereinafter referred to as the Governmental Unit(s), agree as follows:
(Discretely Presented Component Unit)

1. The Auditor shall audit all statements and disclosures required by generally accepted accounting principles (GAAP) and additional required legal statements and disclosures of all funds and/or divisions of the Governmental Unit (s) for the period beginning July 1, 2016, and ending June 30, 2017. The non-major combining, and individual fund statements and schedules shall be subjected to the auditing procedures applied in the audit of the basic financial statements and an opinion will be rendered in relation to (as applicable) the governmental activities, the business-type activities, the aggregate DPCUs, each major governmental and enterprise fund, and the aggregate remaining fund information (non-major government and enterprise funds, the internal service fund type, and the fiduciary fund types).
2. At a minimum, the Auditor shall conduct his/her audit and render his/her report in accordance with generally accepted auditing standards. The Auditor shall perform the audit in accordance with *Government Auditing Standards* if required by the State Single Audit Implementation Act, as codified in G.S. 159-34. If required by OMB *Uniform Administration Requirements, Cost Principles, and Audit Requirements for Federal Awards*, (Uniform Guidance) and the State Single Audit Implementation Act, the Auditor shall perform a Single Audit. This audit and all associated audit documentation may be subject to review by Federal and State agencies in accordance with Federal and State laws, including the staffs of the Office of State Auditor (OSA) and the Local Government Commission (LGC). If the audit and auditor communication are found in this review to be substandard, the results of the review may be forwarded to the North Carolina State Board of CPA Examiners (NC CPA Board).

County and Multi-County Health Departments: The Office of State Auditor will designate certain programs that have eligibility requirements to be considered major programs in accordance with OMB Uniform Guidance for the State of North Carolina. The LGC will notify the auditor and the County and Multi-Health Department of these programs. A County or a Multi-County Health Department may be selected to audit any of these programs as major.
3. If an entity is determined to be a component of another government as defined by the group audit standards - the entity's auditor will make a good faith effort to comply in a timely manner with the requests of the group auditor in accordance with AU-6 §600.41 - §600.42.
4. This contract contemplates an unqualified opinion being rendered. The audit shall include such tests of the accounting records and such other auditing procedures as are considered by the Auditor to be necessary in the circumstances. Any limitations or restrictions in scope which would lead to a qualification should be fully explained in an attachment to this contract.
5. If this audit engagement is subject to the standards for audit as defined in *Government Auditing Standards*, 2011 revisions, issued by the Comptroller General of the United States, then by accepting this engagement, the Auditor warrants that he has met the requirements for a peer review and continuing education as specified in *Government*

268
269

Attachment: 2017-02-20 BOC Minutes - Draft Ltr (1596 : 2017-02-20 BOC Minutes - Draft)

CAMDEN COUNTY BOARD OF COMMISSIONERS

Regular Meeting – February 20, 2017

Contract to Audit Accounts (cont.) Camden County
Primary Governmental Unit

Discretely Presented Component Units (DPCU) if applicable

Auditing Standards. The Auditor agrees to provide a copy of their most recent peer review report regardless of the date of the prior peer review report to the Governmental Unit and the Secretary of the LGC prior to the execution of the audit contract (See Item 22). **If the audit firm received a peer review rating other than pass**, the Auditor shall not contract with the Governmental Unit without first contacting the Secretary of the LGC for a peer review analysis that may result in additional contractual requirements.

If the audit engagement is not subject to Government Accounting Standards or if financial statements are not prepared in accordance with GAAP and fail to include all disclosures required by GAAP, the Auditor shall provide an explanation as to why in an attachment.

- 6. It is agreed that time is of the essence in this contract. All audits are to be performed and the report of audit submitted to the State and Local Government Finance Division (SLGFD) within four months of fiscal year end. Audit report is due on: October 31, 2017. If it becomes necessary to amend this due date or the audit fee, an amended contract along with a written explanation of the delay must be submitted to the secretary of the LGC for approval.
- 7. It is agreed that generally accepted auditing standards include a review of the Governmental Unit's systems of internal control and accounting as same relate to accountability of funds and adherence to budget and law requirements applicable thereto; that the Auditor will make a written report, which may or may not be a part of the written report of audit, to the Governing Board setting forth his findings, together with his recommendations for improvement. That written report must include all matters defined as "significant deficiencies and material weaknesses" in AU-C 265 of the *AICPA Professional Standards (Clarified)*. The Auditor shall file a copy of that report with the Secretary of the LGC.
- 8. All local government and public authority contracts for audit or audit-related work require the approval of the Secretary of the LGC. This includes annual or special audits, agreed upon procedures related to internal controls, bookkeeping or other assistance necessary to prepare the Governmental Unit's records for audit, financial statement preparation, any finance-related investigations, or any other audit-related work in the State of North Carolina. Invoices for services rendered under these contracts shall not be paid by the Governmental Unit until the invoice has been approved by the Secretary of the LGC. (This also includes any progress billings.) [G.S. 159-34 and 115C-447] All invoices for Audit work must be submitted by email in PDF format to the Secretary of the LGC for approval. The invoices must be sent via upload through the current portal address: <http://nc-treasurer-slgfd.ncapfile.net>. Subject line should read "Invoice – [Unit Name]". The PDF invoice marked 'approved' with approval date will be returned by email to the Auditor to present to the Governmental Unit for payment. Approval is not required on contracts and invoices for system improvements and similar services of a non-auditing nature.
- 9. In consideration of the satisfactory performance of the provisions of this contract, the Primary Governmental Unit shall pay to the Auditor, upon approval by the Secretary of the LGC, the fee, which includes any cost the Auditor may incur from work paper or peer reviews or any other quality assurance program required by third parties (Federal and State grantor and oversight agencies or other organizations) as required under the Federal and State Single Audit Acts. (Note: Fees listed on signature pages.)
- 10. If the Governmental Unit has outstanding revenue bonds, the Auditor shall include documentation either in the notes to the audited financial statements or as a separate report submitted to the SLGFD along with the audit report, a calculation demonstrating compliance with the revenue bond rate covenant. Additionally, the Auditor should be aware that any other bond compliance statements or additional reports required in the authorizing bond documents need to be submitted to the SLGFD simultaneously with the Governmental Unit's audited financial statements unless otherwise specified in the bond documents.

Attachment: 2017-02-20 BOC Minutes - Draft Ltr (1596 : 2017-02-20 BOC Minutes - Draft)

CAMDEN COUNTY BOARD OF COMMISSIONERS

Regular Meeting – February 20, 2017

Contract to Audit Accounts (cont.) Camden County
Primary Governmental Unit

Discretely Presented Component Units (DPCU) if applicable

- 11. After completing the audit, the Auditor shall submit to the Governing Board a written report of audit. This report shall include, but not be limited to, the following information: (a) Management's Discussion and Analysis, (b) the financial statements and notes of the Governmental Unit and all of its component units prepared in accordance with GAAP, (c) supplementary information requested by the client or required for full disclosure under the law, and (d) the Auditor's opinion on the material presented. The Auditor shall furnish the required number of copies of the report of audit to the Governing Board as soon as practical after the close of the accounting period.
- 12. If the audit firm is required by the NC CPA Board or the Secretary of the LGC to have a pre-issuance review of their audit work, there must be a statement added to the engagement letter specifying the pre-issuance review including a statement that the Governmental Unit will not be billed for the pre-issuance review. The pre-issuance review must be performed prior to the completed audit being submitted to the LGC. The pre-issuance report must accompany the audit report upon submission to the LGC.
- 13. The Auditor shall electronically submit the report of audit to the LGC as a text-based PDF file when (or prior to) submitting the invoice for services rendered. The report of audit, as filed with the Secretary of the LGC, becomes a matter of public record for inspection, review and copy in the offices of the SLGFD by any interested parties. Any subsequent revisions to these reports must be sent to the Secretary of the LGC. These audited financial statements, excluding the Auditors' opinion, may be used in the preparation of official statements for debt offerings, by municipal bond rating services to fulfill secondary market disclosure requirements of the Securities and Exchange Commission and other lawful purposes of the Governmental Unit without subsequent consent of the Auditor. If it is determined by the LGC that corrections need to be made to the Governmental Unit's financial statements, they should be provided within three days of notification unless another time frame is agreed to by the LGC.

If the OSA designates certain programs to be audited as major programs, as discussed in item #2, a turnaround document and a representation letter addressed to the OSA shall be submitted to the LGC.

The LGC's process for submitting contracts, audit reports and invoices is subject to change. Auditors should use the submission process in effect at the time of submission. The most current instructions will be found on our website: <https://www.nctreasurer.com/slg/Pages/Audit-Forms-and-Resources.aspx>

- 14. Should circumstances disclosed by the audit call for a more detailed investigation by the Auditor than necessary under ordinary circumstances, the Auditor shall inform the Governing Board in writing of the need for such additional investigation and the additional compensation required therefore. Upon approval by the Secretary of the LGC, this contract may be varied or changed to include the increased time and/or compensation as may be agreed upon by the Governing Board and the Auditor
- 15. If an approved contract needs to be varied or changed for any reason, the change must be made in writing, on the Amended LGC-205 contract form and pre-audited if the change includes a change in audit fee. This amended contract needs to be completed in full, including a written explanation of the change, signed and dated by all original parties to the contract, and then must be submitted through the audit contract portal to the Secretary of the LGC for approval. The portal address to upload your amended contract is <http://nctreasurer.slgfd.leapfile.net>. No change shall be effective unless approved by the Secretary of the LGC, the Governing Board, and the Auditor.
- 16. A copy of the engagement letter, issued by the Auditor and signed by both the Auditor and the Governmental Unit should be attached to the contract, and by reference here becomes part of the contract. In case of conflict between the terms of the engagement letter and the terms of this contract, the terms of this contract will control. Engagement letter terms that conflict with the contract are deemed to be void unless the conflicting terms of this contract are specifically deleted in Item #25 of this contract. Engagement letters containing indemnification clauses will not be approved by the LGC.

Attachment: 2017-02-20 BOC Minutes - Draft Ltr (1596 : 2017-02-20 BOC Minutes - Draft)

CAMDEN COUNTY BOARD OF COMMISSIONERS

Regular Meeting – February 20, 2017

Contract to Audit Accounts (cont.) Camden County
 Primary Governmental Unit.

 Discretely presented component units if applicable

- 17. Special provisions should be limited. Please list any special provisions in an attachment.
- 18. A separate contract should not be made for each division to be audited or report to be submitted. If a DPCU is subject to the audit requirements detailed in the Local Government Budget and Fiscal Control Act and a separate audit report is issued, a separate audit contract is required. If a separate report is not to be issued and the DPCU is included in the primary government audit, the DPCU must be named along with the parent government on this audit contract. Signatures from the DPCU Board chairman and finance officer also must be included on this contract.
- 19. The contract must be executed, pre-audited, physically signed by all parties including Governmental Unit and Auditor signatures and submitted in PDF format to the Secretary of the LGC. The current portal address to upload your contractual documents is <http://nctreasurer.slgfd.leapfile.net>. Electronic signatures are not accepted at this time. Included with this contract are instructions to submit contracts and invoices for approval as of November 2016. These instructions are subject to change. Please check the NC Treasurer's web site at <https://www.nctreasurer.com/slg/Pages/Audit-Forms-and-Resources.aspx> for the most recent instructions.
- 20. The contract is not valid until it is approved by the LGC Secretary. The staff of the LGC shall notify the Governmental Unit and Auditor of contract approval by email. **The audit should not be started before the contract is approved.**
- 21. There are no other agreements between the parties hereto and no other agreements relative hereto that shall be enforceable unless entered into in accordance with the procedure set out herein and approved by the Secretary of the LGC.
- 22. **E-Verify.** Auditor shall comply with the requirements of NCGS Chapter 64 Article 2. Further, if Auditor utilizes any subcontractor(s), Auditor shall require such subcontractor(s) to comply with the requirements of NCGS Chapter 64, Article 2.
- 23. Contractor hereby certifies that Contractor, and all subcontractors, are not on the Iran Final Divestment List ("List") created by the North Carolina State Treasurer pursuant to N.C.G.S. 147-86.58. Contractor shall not utilize any subcontractor that is identified on the List.
- 25. All of the above paragraphs are understood and shall apply to this contract, except the following numbered paragraphs shall be deleted: (See Item 16 for clarification).

272
273

Attachment: 2017-02-20 BOC Minutes - Draft Ltr (1596 : 2017-02-20 BOC Minutes - Draft)

CAMDEN COUNTY BOARD OF COMMISSIONERS

Regular Meeting – February 20, 2017

274
275

K. BANK SIGNATURE CARD RESOLUTION



CAMDEN OFFICE
178 Us 158 West, Camden, NC 27921

BANK RESOLUTION BY GOVERNMENT ENTITY

SECRETARY'S CERTIFICATE. I certify that I am the secretary of COUNTY OF CAMDEN ("Entity"), a government entity in good standing under the laws of North Carolina. The following is an accurate copy of resolutions adopted by the Entity's governing body at a meeting properly called and held on December 9, 2016, at which a quorum was present. Such resolutions have not been amended or revoked, and they do not conflict with any provision of any document by which the Entity is bound:

RESOLVED, that TOWNEBANK ("Bank") is designated a depository of funds for the Entity;

RESOLVED, that any prior resolutions remain in effect except as changed by those adopted today. The Entity ratifies all transactions purportedly done on its behalf with the Bank before these resolutions were delivered to the Bank. Any change(s) to these resolutions will take effect only after the Bank has received written certification of the change(s) and has had reasonable time to act on the change(s);

RESOLVED, that the Entity agrees to be bound by the Bank's Commercial Deposit Account Agreement for each account permitted by these resolutions;

RESOLVED, that the Bank is authorized to honor, pay, and charge the Entity's account(s) for any item purporting to have been signed on behalf of the Entity with a facsimile signature that resembles a specimen the Entity has certified to the Bank, no matter by whom or by what means the actual or purported signature may have been made;

RESOLVED, that the persons named below, whose manual and/or facsimile signatures are provided next to their respective names, are authorized to perform the powers listed based on number(s) following their respective names. The Bank has no duty to inquire into any power before executing it, even if the power benefits the signer individually. The required number of signatures immediately follows the description of that power;

Powers:

1. Open and close deposit accounts, sign account agreements, and sign contracts for deposit-related or other services. Signatures required: 1
2. Sign and authorize checks, drafts, withdrawal slips, and any other orders for the payment of money, whether by paper, electronic, or any other means, even if payable to the signer or used to discharge or reduce any obligation of the signer. Signatures required: 1
3. Borrow money by signing promissory notes, checks, drafts, credit agreements, agreements for letters of credit, and any other contracts that obligate the Entity to repay funds. Signatures required: 0
4. Assign, endorse, discount, transfer, mortgage, or pledge any of the Entity's property as collateral for any obligation, direct or indirect, absolute or contingent. Signatures required: 0
5. Lease, have access to, and terminate leases for safe-deposit boxes. Signatures required: 0
6. Give releases, waivers, receipts, and notices of all kinds that relate in any way to any relationship of the Entity with the Bank. Signatures required: 0

RESOLVED, that the secretary of the Entity is directed to certify and deliver a copy of these resolutions to the Bank, the signature cards bearing the genuine signatures of the persons named below, and any other documents that the Bank requires.

AUTHORIZED PERSONS. The names and genuine signatures, manual or facsimile, of the authorized persons, and the powers granted to them are as follows:

Name STEPHANIE M HUMPHRES	Title Finance Officer	Powers 1 and 2 - as to account number(s) 000007251284103, 000007251284120
Signature _____	Facsimile Signature _____	
Name SAVORA B JONES	Title Assistant Finance Officer	Powers 1 and 2 - as to account number(s) 000007251284103, 000007251284120
Signature _____	Facsimile Signature _____	
Name CLAYTON D RIGGS	Title	Powers 2 - as to account number(s) 000007251284103, 000007251284120
Signature _____	Facsimile Signature _____	

IN WITNESS WHEREOF, I have signed this certification on the date shown by my signature and have affixed the Entity's seal.

COUNTY OF CAMDEN

276
277

Attachment: 2017-02-20 BOC Minutes - Draft Ltr (1596 : 2017-02-20 BOC Minutes - Draft)

CAMDEN COUNTY BOARD OF COMMISSIONERS

Regular Meeting – February 20, 2017

278

279 **L. DESIGNATION OF APRIL AS ALBEMARLE SENIOR GAMES PARTICIPATION MONTH**

280

281

PROCLAMATION

282

283

Designation of April as Albemarle Senior Games Participation Month

284

285 **WHEREAS**, mature adults and the entire community look forward to the Albemarle Senior
 286 games, an Olympic style event designed to create year-round health promotion and completion
 287 for participants that are 50 years of age and better; and

288

289 **WHEREAS**, the Albemarle Senior Games, held March 27-May 23 of this year, is sanctioned by
 290 North Carolina Senior Games, Inc.; and

291

292 **WHEREAS**, the Albemarle Senior Games takes a holistic approach by involving the body, mind
 293 and spirit of its athletes and promoting the importance of aging in a healthy manner; and

294

295 **WHEREAS**, the regional event, engaging the counties of Camden, Chowan, Currituck, Gates,
 296 Hyde, Pasquotank, Perquimans, Tyrrell and Washington with the goal to enhance growth,
 297 development and connection to opportunity for all participants and volunteers, was founded 33
 298 years ago, in 1984; and

299

300 **WHEREAS**, participants will compete in a total of 48 athletic events and 34 artistic categories;
 301 and

302

303 **WHEREAS**, our well wishes are extended to all of the competitors.

304

305 **NOW THEREFORE**, the Camden County Board of Commissioners hereby proclaims that April be
 306 recognized as Senior Games Participation Month in the County of Camden, and promotes
 307 participation as well as volunteerism within the Albemarle Senior Games program.

308

309 **ADOPTED** this 21st day of February, 2017.

310 **M. USDA FUNDING APPLICATION**

311

312 USDA funding terms are more favorable than bank loans. An official resolution will be required
 313 once USDA determines Camden's eligibility should we accept the terms.

314

315 The initial application is for eligibility only and does not obligate the county to accept the USDA
 316 funding offer.

CAMDEN COUNTY BOARD OF COMMISSIONERS
 Regular Meeting – February 20, 2017

317 N. PERSONNEL SALARY ADJUSTMENT

POSITION CLASSIFICATION ACTION FORM

FISCAL YEAR 2016-2017

DEPARTMENT NUMBER 526100 DEPARTMENT NAME Social Services

REQUEST FOR ACTION

PRESENT POSITION CLASSIFICATION	PRESENT SALARY	GRADE/STEP	POSITION NUMBER
<u>Administrative Assistant I</u>	<u>41,757.00</u>	<u>62</u>	<u>129-16-001</u>
PROPOSED POSITION CLASSIFICATION	PROPOSED SALARY	GRADE/STEP	PROPOSED EFFECTIVE DATE
<u>Administrative Officer I</u>	<u>43,844.85</u>	<u>66</u>	<u>10/1/2016</u>
ADDITIONAL SALARY REQUIRED	ADDITIONAL FRINGES REQUIRED	TOTAL ADDITIONAL COST	NEW POSITION NUMBER
<u>2,087.85</u>	<u>725.12</u>	<u>2,812.97</u>	<u>Same</u>

RECOMMENDED BY: [Signature] DATE 2/2/2017
Signature (Department Head)

APPROVED BY: [Signature] DATE 2/3/2017
County Manager

(Continued) CB-3

318

319 O. SURPLUS - DISMAL SWAMP WELCOME CENTER

320

Requested by: Donna Stewart

Sell Dispose

Department: Dismal Swamp Welcome Center

Item: Metal Bistro Table and two chairs - foldable

Disposal Method: Purchased by Sarah Hill

Suggested Value: \$58.71

Reason for surplus: Replaced with a nicer item. Interim Plus market purcha

Manager Approval

Disposal Method: Sell to Employee

Value: \$58.71

Comments: Recommend Approval:
[Signature] - Michael Bill Mart

Item Description

This metal fold-up bistro table and chairs was purchased as an Interim item for boaters to sit with tables, etc. This has been replaced with a nice desk and chair. See attached invoice of purchase.

321
322

Attachment: 2017-02-20 BOC Minutes - Draft Ltr (1596 : 2017-02-20 BOC Minutes - Draft)

CAMDEN COUNTY BOARD OF COMMISSIONERS

Regular Meeting – February 20, 2017

323
324

325 P. SURPLUS - 2008 DODGE CHARGER

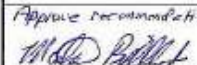
Requested by:	Sheriff Tony Perry	<input checked="" type="radio"/> Sell <input type="radio"/> Dispose
Department:	Sheriff's Office	
Item:	2008 Dodge Charger	Item Description 2008 Dodge Charger , Brown , runs good , interior in good condition , AC cold , FM/AM Single Disc CD , 186,030 miles Vin # 2B3KA43H58H134185
Disposal Method:	GovDeals	
Suggested Value:	\$1500.00	
Reason for surplus:	Removed from fleet	
Manager Approval		
Disposal Method:	GovDeals	
Value:	\$1500.00	
Comments:	Approve recommendation. 	

326

327 Q. RESOLUTION NO. 2017-02-02
328 OPPOSING SPECIAL SECONDARY NURSERY AREAS

RESOLUTION No. 2017-02-02

Opposing the Designation of Special Secondary Nursery Areas

329

330

331

332 **WHEREAS**, a petition for rulemaking to designate Special Secondary Nursery Areas and Reduce Bycatch
333 Mortality has been submitted to the NC Marine Fisheries Commission by the NC Wildlife Federation; and,

334

335 **WHEREAS**, the petition seeks to designate all inshore and ocean waters out to three miles as Special
336 Secondary Nursery Areas and define the type of gear and how and when gear may be used during shrimp
337 season; and,

338

339 **WHEREAS**, if adopted, the petition would severely limit shrimp trawling, which would have a devastating
340 impact on commercial fishing families by arbitrarily impairing their livelihood and depriving American
341 tables of fresh, healthy catches of North Carolina harvested shrimp; and,

342

343 **WHEREAS**, shrimp trawling has been a vibrant and successful part of North Carolina's heritage and
344 culture for all of its history and represents a means by which generations of commercial watermen
345 create jobs, provide for their families, and contribute to the economic wellbeing of North Carolina's
346 coastal communities; and

347

CAMDEN COUNTY BOARD OF COMMISSIONERS

Regular Meeting – February 20, 2017

348 **WHEREAS**, existing state and federal regulations provide ample provisions for monitoring and regulation
349 of commercial shrimping with serious penalties and sanctions for rule violations, which have proven to be
350 effective in preventing overfishing and waste.

351
352 **NOW THEREFORE BE IT RESOLVED** that the Camden County Board of Commissioners hereby opposes the
353 petition for rulemaking to Designate Special Secondary Nursery Areas and Reduce Bycatch Mortality in
354 North Carolina Coastal Fishing Waters as set forth by the NC Wildlife Federation and strongly urges the
355 North Carolina Marine Fisheries Commission to reject it.

356
357 **BE IT FURTHER RESOLVED** that the Camden County Board of Commissioners asks all coastal communities
358 to support North Carolina's working watermen by adopting similar resolutions in opposition of this
359 petition for rulemaking that would put North Carolina shrimping in jeopardy.

360
361 **ADOPTED** this 20th day of February, 2017.

362 R. SET PUBLIC HEARING:
363 SPECIAL USE PERMIT FOR PRELIMINARY PLAT MILL RUN - COMMON
364 OPEN SPACE MAJOR SUBDIVISION (UDO 2015-06-07)

365
366 *Harbinger Land & Timber LLC / Assorted Development Corporation has applied for Preliminary*
367 *Plat approval for Mill Run Common Open Space Subdivision (45 lots) (Article 151.290 of the*
368 *Camden County Code of Ordinances). Application will be heard by the Planning Board on*
369 *February 15, 2017 with recommendation to be provided at the public hearing.*

370
371 *Rezoning from Basic Residential (R3-2) to Basic Residential (R3-1) approved by Board of*
372 *Commissioners on June 1, 2015 (Ordinance No. 2015-04-01). Sketch / Yield Plan approved by the*
373 *Board of Commissioners on September 8, 2015.*

374
375 *Set Public Hearing for April 3rd, 2017*
376

377 **9. COMMISSIONERS' REPORT**

378 *Vice Chair Tom White attended the NCACC Legislative Conference in Raleigh.*
379

380 **10. COUNTY MANAGER'S REPORT**

381 **A. DISCUSSION WITH REGARD TO SOLAR FARMS**

382 *Solar Farms Discussion - in light of recent development application activity specific to solar*
383 *farms in Camden County, there is a concern that the County's adopted UDO standards may not*

Attachment: 2017-02-20 BOC Minutes - Draft Ltr (1596 : 2017-02-20 BOC Minutes - Draft)

CAMDEN COUNTY BOARD OF COMMISSIONERS

Regular Meeting – February 20, 2017

384 *be adequate in addressing all aspects of solar farms land development in the most*
385 *comprehensive manner.*

386
387 *Staff is recommending that an examination of other local government UDO requirements*
388 *specific to solar farms be undertaken. This analysis could also identify which zoning districts are*
389 *most practical for future solar farms to be located.*

390
391 *Vice Chairman Tom White mentioned that having a public hearing on the matter may be a good*
392 *idea.*

393
394 *Commissioner Randy Krainiak made a motion to hold a Public Hearing on March 20th, 2017 to*
395 *consider a Moratorium on Solar Farms in Camden County*
396

397	RESULT:	ADOPTED [UNANIMOUS]
398	MOVER:	Randy Krainiak, Commissioner
399	AYES:	White, Krainiak, Munro
400	ABSENT:	Riggs, Meiggs

401

SOUTH CAMDEN WATER & SEWER DISTRICT
BOARD OF DIRECTORS

RECESS

405 *At 7:51 P.M. Vice Chairman Tom White recessed the Commissioners meeting to enter into the*
406 *South Camden Water and Sewer District Board of Directors meeting.*

407	RESULT:	PASSED [UNANIMOUS]
408	AYES:	White, Krainiak, Munro
409	ABSENT:	Riggs, Meiggs

410

RECONVENE

412 *At 7:56 PM Vice Chairman Tom White made a motion to reconvene the Board of Commissioners*
413 *meeting.*

Attachment: 2017-02-20 BOC Minutes - Draft Ltr (1596 : 2017-02-20 BOC Minutes - Draft)

CAMDEN COUNTY BOARD OF COMMISSIONERS

Regular Meeting – February 20, 2017

414 **RESULT:** PASSED [UNANIMOUS]
 415 **MOVER:** Tom White, Commissioner
 416 **AYES:** White, Krainiak, Munro
 417 **ABSENT:** Riggs, Meiggs

11. INFORMATION, REPORTS & MINUTES FROM OTHER AGENCIES

419 (The following informational items are kept on file in the office of the Clerk to the Board for public review)

- 420 A. *Sales & Use Tax Collection Report*
 421 B. *Legislative Goals Conference*
 422 C. *December 2016 Library Statistics*
 423 D. *2016 Audit - Albemarle District Jail*
 424 E. *Tar Heels in the Trenches: The Albemarle and the Great War Exhibit Opening*
 425 F. *Museum of the ALBEMARLE HISTORY for Lunch*
 426 G. *Monthly Report - REGISTER OF Deeds January 2017*
 427 H. *Unfunded Mandates and Other Regulatory Impacts on Counties NACO*
 428 I. *Disaster Recovery - Notice of Available Fund*
 429

12. OTHER MATTERS

431 *None*

13. ADJOURN

433 *At 7:58 PM Vice Chairman Tom White adjourned the Camden County Board of Commissioners*
 434 *meeting*

435 **RESULT:** PASSED [UNANIMOUS]
 436 **MOVER:** Tom White, Commissioner
 437 **AYES:** White, Krainiak, Munro
 438 **ABSENT:** Riggs, Meiggs

439

440

441

442

443

444

ATTEST:

Vice Chairman Tom White
Camden County Board of Commissioners

CAMDEN COUNTY BOARD OF COMMISSIONERS
Regular Meeting – February 20, 2017

445

446

447

448 *Angela L. Wooten*

449 *Clerk to the Board*

DRAFT

Attachment: 2017-02-20 BOC Minutes - Draft Ltr (1596 : 2017-02-20 BOC Minutes - Draft)



CAMDENCOUNTY

new energy. new vision.

Board of Commissioners AGENDA ITEM SUMMARY SHEET

Consent Agenda

Item Number: 8.C
Meeting Date: March 06, 2017

Submitted By: Stephanie Humphries, Finance Director
 Finance
 Prepared by: Stephanie Humphries

Item Title **16-17 Budget Amendments**

Attachments: 16-17-BA015 JCPC salaries (DOC)
 16-17-BA016 LESO revenue (DOC)
 16-17-BA017 Extension Programming (DOC)

Summary: Budget Amendments
 BA0015-JCPC Grant Adjustments
 BA0016-LESO Equipment
 BA0017-Extension Programming

Recommendation: **Approve**

2016-17-BA015
CAMDEN COUNTY BUDGET AMENDMENT

BE IT ORDAINED by the Governing Board of the County of Camden, North Carolina that the following amendment be made to the annual budget ordinance for the fiscal year ending June 30, 2017.

Section 1. To amend the General Fund as follows:

ACCT NUMBER	DESCRIPTION OF ACCT	AMOUNT	
		INCREASE	DECREASE
Expenses			
106200-502000	Salaries	\$ 758	
106200-503000	Part Time Salaries	\$ 283	
106200-505000	FICA	\$ 80	
106200-506000	Health Insurance		\$5,423
106200-507000	Retirement	\$ 134	
106200-507100	401K	\$ 37	
106200-509000	Worker's Compensation		\$ 9
106200-570002	Crown Kids	\$4,140	

This Budget Amendment is made to adjust Salaries for Full Time Coordinator and Part Time Camp wages. Adjustment is for change in staffing, not an increase in employee salary. Any changes to salary lines require board approval.

This will result in no change to the Contingency of the General Fund.

Balance in Contingency \$40,000.00

Section 2. Copies of this budget amendment shall be furnished to the Clerk to the Governing Board and to the Budget Officer and the Finance Officer for their direction. Adopted this 20th day of February, 2017.

Clerk to Board of Commissioners

Chairman, Board of Commissioners

Attachment: 16-17-BA015 JCPC salaries (1573 : 16-17 Budget Amendments)

2016-17-BA016
CAMDEN COUNTY BUDGET AMENDMENT

BE IT ORDAINED by the Governing Board of the County of Camden, North Carolina that the following amendment be made to the annual budget ordinance for the fiscal year ending June 30, 2017.

Section 1. To amend the General Fund as follows:

ACCT NUMBER	DESCRIPTION OF ACCT	AMOUNT	
		INCREASE	DECREASE
Revenues			
10330510-402003	LESO Sales Revenue	\$4,190	
Expenses			
105100-557003	LESO Equipment Expense	\$4,190	
105100-557000	Miscellaneous	\$1,000	
105100-504100	Attorney Fees		\$1,000

This Budget Amendment is made appropriate funds for LESO sales revenue received.

This will result in no change to the Contingency of the General Fund.

Balance in Contingency \$40,000.00

Section 2. Copies of this budget amendment shall be furnished to the Clerk to the Governing Board and to the Budget Officer and the Finance Officer for their direction. Adopted this 6th day of March, 2017.

 Clerk to Board of Commissioners

 Chairman, Board of Commissioners

Attachment: 16-17-BA016 LESO revenue (1573 : 16-17 Budget Amendments)

2016-17-BA017
CAMDEN COUNTY BUDGET AMENDMENT

BE IT ORDAINED by the Governing Board of the County of Camden, North Carolina that the following amendment be made to the annual budget ordinance for the fiscal year ending June 30, 2017.

Section 1. To amend the General Fund as follows:

ACCT NUMBER	DESCRIPTION OF ACCT	AMOUNT	
		INCREASE	DECREASE
Revenues			
10340605-432700	Fees Collected	\$2,000	
Expenses			
106050-544002	Extension Programming Expense	\$2,000	

This Budget Amendment is made appropriate funds for Extension Programming revenue.

This will result in no change to the Contingency of the General Fund.

Balance in Contingency \$40,000.00

Section 2. Copies of this budget amendment shall be furnished to the Clerk to the Governing Board and to the Budget Officer and the Finance Officer for their direction. Adopted this 6th day of March, 2017.

 Clerk to Board of Commissioners

 Chairman, Board of Commissioners

Attachment: 16-17-BA017 Extension Programming (1573 : 16-17 Budget Amendments)



CAMDENCOUNTY

new energy. new vision.

Board of Commissioners AGENDA ITEM SUMMARY SHEET

Consent Agenda

Item Number: 8.D
Meeting Date: March 06, 2017
Submitted By: Angela Wooten, Clerk to the Board
 Administration
 Prepared by: Angela Wooten

Item Title **CCS Budget Amendments**

Attachments: ccs ba 1 (PDF)
 ccs ba 2 (PDF)

Summary:

CCS Budget Amendments

Recommendation:

Review and Approve

Budget Amendment

Camden County Schools Administrative Unit



Local Current Expense Fund

The Camden County Board of Education at a meeting on the 9th day of February, 2017 passed the following resolution.

Be it resolved that the following amendments be made to the Budget Resolution for the fiscal year ending June 30, 2017.

Code Number	Description of Code	Amount	
		Increase	Decrease
Explanation:			
	Total Appropriation in Current Budget	\$ 2,385,686.00	
	Amount of Increase/Decrease of Above Amendment		.00
	Total Appropriation in Current Amended Budget	\$ 2,385,686.00	

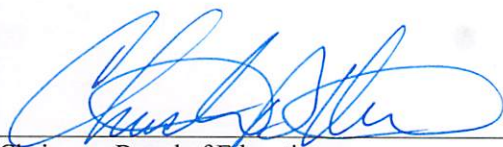
Attachment: ccs ba 1 (1571 : CCS Budget Amendments)

<p>Passed by majority vote of the Board of Education of Camden County on the 9th day of February 2017.</p>  <p>Chairman, Board of Education</p>  <p>Secretary, Board of Education</p>	<p>We the Board of County Commissioners of Camden County hereby approve the changes in the County School Funds Budget as indicated above, and have made entry of these changes on the minutes of said Board, this ____ day of _____ 20__.</p> <p>_____</p> <p>Chairman, Board of County Commissioners</p> <p>_____</p> <p>Clerk, Board of County Commissioners</p>
------------------------------------------------------------------------------------------------------------------------------------------------------------------------------------------------------------------------------------------------------------------------------------------------------------------------------------------------------------------------	--------------------------------------------------------------------------------------------------------------------------------------------------------------------------------------------------------------------------------------------------------------------------------------------------------------------------------------------------------------------

BUDGET AMENDMENT
February 9, 2017

2. Local Current Expense Fund

A. We have reviewed this program area and find that we must transfer funds to within to cover expenses. We request your approval of the following amendment.

Operation of Plant

6540.802.231	Emp Hosp Ins Costs	\$	+	1,500.00
6540.802.311	Contracted Services		-	<u>1,500.00</u>

Total – Operation of Plant \$ + 0.00

B. We have reviewed this area of the budget and find that we must transfer funds to cover subs and travel for itinerant teachers. We request your approval of the following amendment.

Classroom Support

5110.842.162	Substitute Pay	\$	-	300.00
5110.842.332	Travel		+	<u>300.00</u>

Total – Classroom Support \$ + .00

C. We have reviewed this program area and find that we must transfer funds within to cover expenses of the budget. We request your approval of the following amendment.

Office of The Superintendent

6940.865.129	Salary – Differential Pay	\$	+	1,850.00
6940.865.373	Building & Grounds Insurance		-	2,883.00
6940.865.459	Other Food Purchases		+	1,000.00
6940.865.462	Pur of Non-Cap Comp Hdwe		+	<u>33.00</u>

Total – Office of The Superintendent \$ + 0.00

D. We have reviewed this area of the budget and must transfer funds to cover benefit expenses. We request your approval of the following amendment.

Additional Pay

5110.911.180	Bonus Pay	\$	+	215.00
5110.911.181	Supplementary Pay		-	<u>215.00</u>

Total – Additional Pay \$ + .00

Attachment: ccs ba 1 (1571 : CCS Budget Amendments)

BUDGET AMENDMENT
Local Current Expense Fund
February 9, 2017, Page 2

Passed by majority vote of the Board of
Education of Camden County on the 9th
day of February, 2017.



Chairman, Board of Education



Secretary, Board of Education

Attachment: ccs ba 1 (1571 : CCS Budget Amendments)

Budget Amendment

Camden County Schools Administrative Unit



Other Local Current Expense Fund

The Camden County Board of Education at a meeting on the 9th day of February, 2017 passed the following resolution.

Be it resolved that the following amendments be made to the Budget Resolution for the fiscal year ending June 30, 2017.

Code Number	Description of Code	Amount	
		Increase	Decrease
6400	Technology Support Services		50.00
6500	Operational Support Services	50.00	
Explanation:			
Total Appropriation in Current Budget		\$	876,826.27
Amount of Increase/Decrease of Above Amendment			.00
Total Appropriation in Current Amended Budget		\$	876,826.27

Attachment: ccs ba 2 (1571 : CCS Budget Amendments)

<p>Passed by majority vote of the Board of Education of Camden County on the 9th day of February 2017.</p>  <p>Chairman, Board of Education</p>  <p>Secretary, Board of Education</p>	<p>We the Board of County Commissioners of Camden County hereby approve the changes in the County School Funds Budget as indicated above, and have made entry of these changes on the minutes of said Board, this ____ day of _____ 20 ____.</p> <p>_____ Chairman, Board of County Commissioners</p> <p>_____ Clerk, Board of County Commissioners</p>
------------------------------------------------------------------------------------------------------------------------------------------------------------------------------------------------------------------------------------------------------------------------------------------------------------------------------------------------------------------------	-----------------------------------------------------------------------------------------------------------------------------------------------------------------------------------------------------------------------------------------------------------------------------------------------------------------------------------------------------------------

BUDGET AMENDMENT
February 9, 2017

8. Other Local Current Expense Fund

A. We have reviewed this area of the budget and find that we must transfer funds to cover expenses within this area of the budget. We request your approval of the following amendment.

Activity Bus

6550.706.211	Emp Soc Sec Costs	\$	-	10.00
6550.706.231	Emp Hosp Ins Costs		+	<u>10.00</u>

Total – Activity Bus \$ + .00

B. We have reviewed this area of the budget and find that we must transfer funds to cover expenses within this program area. We request your approval of the following amendment.

Computer Tech

6400.905.343	Telephone for Telecommunications	\$	-	50.00
6510.905.341	Telephone for Telecomm - Lines		+	<u>50.00</u>

Total – Computer Tech \$ + .00

Passed by majority vote of the Board of Education of Camden County on the 9th day of February, 2017.

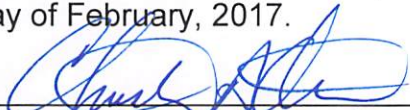

Chairman, Board of Education



Secretary, Board of Education

Attachment: ccs ba 2 (1571 : CCS Budget Amendments)



Board of Commissioners
AGENDA ITEM SUMMARY SHEET

Consent Agenda

Item Number: 8.E
Meeting Date: March 06, 2017
Submitted By: Terri Smith,
Taxes
Prepared by: Terri Smith
Item Title VTS Refunds Over \$100.00
Attachments: VTS Refunds over 100 (PDF)
Summary: Refunds Over \$100.00 for January, 2017
Recommendation: Review and Approve

REFUNDS OVER \$100.00

North Carolina Vehicle Tax System

NCVTS Pending Refund report

REFUNDS OVER \$100.00 JAN, 17



Payee Name	Primary Owner	Secondary Owner	Address 1	Address 3	Refund Type	Bill #	Plate Number	Status	Transaction #	Refund Description	Refund Reason	Create Date	Authorization Date	Tax Jurisdiction	Levy Type	Change	Interest Change	Total Change
DOWD, ANTHONY M	DOWD, ANTHONY M	92 PRESWICK DR	ROCKY POINT, NC 28457	NC 28457	Adjustment >= \$100	0033404768	DKW6414	AUTHORIZED	61610410	Refund Generated due to adjustment on Bill #0033404768-2016-2016-0000-00	Military	01/27/2017	1/31/2017 8:15:13 AM	1843	Tax	(\$130.22)	\$0.00	(\$130.22)
MARTIN, CHRISTOPHER DALE	MARTIN, CHRISTOPHER DALE	112 CAROLINA RD	SOUTH MILLS, NC 27976	NC 27976	Proration	0034827019	EFR3314	PENDING	61801032	Refund Generated due to proration on Bill #0034827019-2016-2016-0000-00	Tag Surrender	01/31/2017		1843	Tax	(\$325.65)	\$0.00	(\$325.65)
														1	Tax	(\$4.78)	\$0.00	(\$4.78)
																	Refund	\$132.14
																	Refund	\$330.43

Submitted by Lisa S. Anderson Date 2-6-17

Lisa S. Anderson, Tax Administrator Camden County

Approved by _____ Date _____

Clayton D. Riggs, Chairman Camden County Board of Commissioners



Board of Commissioners
AGENDA ITEM SUMMARY SHEET

Consent Agenda

Item Number: 8.F
Meeting Date: March 06, 2017

Submitted By: Terri Smith,
Taxes
Prepared by: Terri Smith

Item Title **DMV Monthly Report - April Renewals**

Attachments: dmv monthly report - April (DOC)

Summary: DMV Monthly Report April Renewals Due 5/15/17

Recommendation: Review and Approve

STATE OF NORTH CAROLINA

COUNTY OF CAMDEN

TO: The Tax Administrator of Camden County April Ren. Due 5/15/17

You are hereby authorized, empowered, and commanded to collect the taxes set forth in the tax records filed in the office of the Tax Administrator and in the tax receipts herewith delivered to you, in the amounts and from the taxpayers likewise therein set forth. Such taxes are hereby declared to be a first lien upon personal property of the respective taxpayers in the County of Camden, and this order shall be a full and sufficient authority to direct, require, and enable you to levy on and sell personal property of such taxpayers for and on account thereof, in accordance with the law.

SOUTH MILLS	COURTHOUSE	SHILOH	TOTAL
19,788.95	18,452.19	11,700.95	49,942.09

Witness my hand and official seal this _____ day of _____

Chairman, Camden County Board of Commissioners

Attest:

Clerk to the Board of Commissioners of Camden County

This is to certify that I have received the tax receipts and duplicates for collection in the amounts as listed herein.

Tax Administrator of Camden County

Attachment: dmV monthly report - April (1569 : DMV Monthly Report - April Renewals)



CAMDENCOUNTY
new energy. new vision.

Board of Commissioners
AGENDA ITEM SUMMARY SHEET

Consent Agenda

Item Number: 8.G

Meeting Date: March 06, 2017

Submitted By: Angela Wooten, Clerk to the Board
Administration
Prepared by: Angela Wooten

Item Title **National County Government Month April 2017 -
Proclamation**

Attachments: Proclamation National County Government Month
(DOCX)
NCGM toolkit_2017 (PDF)

Summary:
Proclamation

National County Government Month April 2017 - Brilliant Ideas at Work

Recommendation:

Review and Approve

National County Government Month - April 2017

"Brilliant Ideas at Work"

WHEREAS, the nation’s 3,069 counties serving more than 300 million Americans provide essential services to create healthy, safe and vibrant; and

WHEREAS, counties move America forward by providing health care, administering justice, keeping communities safe, creating economic opportunities and much more; and

WHEREAS, Camden County and all counties take pride in their responsibility to protect and enhance the health, welfare and safety of its residents in efficient and cost-effective ways; and

WHEREAS, through National Association of Counties President Bryan Desloge’s “Brilliant Ideas at Work” initiative, NACo is encouraging counties to focus on the most innovative programs and services that strengthen communities; and

WHEREAS, in order to remain healthy, vibrant and safe, America’s counties provide public health, justice, safety, infrastructure, transportation, technology, environmental stewardship and economic services that play a key role in everything from residents’ daily commutes to emergency response; and

WHEREAS, each year since 1991 the National Association of Counties has encouraged counties across the country to actively promote their own programs and services to the public they serve; and

NOW, THEREFORE, BE IT RESOLVED THAT I, Clayton D. Riggs, Chairman of the Camden County Board of Commissioners do hereby proclaim April 2017 as National County Government Month and encourage all county officials, employees, schools and residents to participate in county government celebration activities.

Clayton D. Riggs, Chairman
Board of Commissioners

ATTEST:

Angela L. Wooten
Clerk to the Board

Attachment: Proclamation National County Government Month (1554 : National County Government Month - Proclamation)



8.G.2



BRILLIANT IDEAS AT WORK



NATIONAL
COUNTY
GOVERNMENT
MONTH

APRIL 2017



Attachment: NCGM toolkit 2017 (1554 : National County Government Month - Proclamation)



National County Government Month (NCGM), held each April, is an annual celebration of county government. Since 1991, the National Association of Counties has encouraged counties to actively promote the services and programs they offer. Counties can schedule activities any time during the month. NCGM is an excellent opportunity for your county to highlight effective county programs and raise public awareness and understanding about the various services provided to the community.

NACo's VISION:

Healthy, vibrant and safe counties across the United States.

NACo's MISSION:

The National Association of Counties (NACo) unites America's 3,069 county governments. Through NACo, county officials:

- Advocate with a collective voice on national policy
- Exchange ideas and build new leadership skills
- Pursue transformational, cost-effective solutions
- Enrich the public's understanding of county government, and
- Exercise exemplary leadership in public service.



PRESIDENTIAL MESSAGE & INITIATIVE

Dear Fellow County Leader,

Counties play an essential role in keeping America's communities healthy, vibrant and safe. With public and private sector partners, we pursue innovative approaches to advance public health and well-being, protect public safety, foster economic strength and so much more.



As I participate in state association meetings and visit counties across the country, I'm always amazed by counties' ability to find a way forward. Counties overcome complex challenges, provide essential services to residents, save taxpayers money and constantly do more with less. Yet, our successes don't receive nearly the attention they deserve.

As NACo's president, I wanted to find ways to recognize these innovations – and help NACo members learn from one another's best practices. That's why we launched the **Counties Matter Challenge: Brilliant Ideas at Work** initiative. And this year's theme for National County Government Month is **Brilliant Ideas at Work**.

During the month of April, I encourage you to feature the county programs and initiatives you're proudest of. This toolkit provides ideas on how you can raise public awareness of your county's **Brilliant Ideas at Work**.

Beyond National County Government Month, through the **Counties Matter Challenge**, we are identifying and sharing 100 examples of visionary county leadership that is improving residents' quality of life. Though no two of America's 3,069 counties are alike, many face similar challenges and can learn from one another.

In conjunction with NACo's [Achievement Awards](#), we are building an online honor roll that highlights county innovation at its best. By applying for the 2017 NACo Achievement Awards, your entry will be in the running for the **Counties Matter Challenge**. The deadline to apply is March 27, and Counties Matter Challenge winners will be announced in May, in time for you to be recognized at NACo's Annual Conference in Franklin County (Columbus), Ohio, July 21 – 24. Apply today at www.NACo.org/AchievementAwards.

What are your **Brilliant Ideas at Work**? Use National County Government Month to highlight them, and apply for the **Counties Matter Challenge**. Let your citizens know how your county is leading the way. To remain healthy, vibrant and safe, counties anticipate and adapt to challenges by thinking outside the box and demonstrating local leadership that makes a difference in people's lives.

The Hon. Bryan Desloge
NACo President
Commissioner, Leon County, Fla.



Attachment: NCGM toolkit_2017 (1554 : National County Government Month - Proclamation)



GETTING STARTED

THIS YEAR'S THEME IS 'BRILLIANT IDEAS AT WORK.'

National County Government Month (NCGM) is an annual celebration of county government held each April. Since 1991, the National Association of Counties has encouraged counties to actively promote the services and programs they offer. Counties can schedule activities any time during the month. NCGM is an excellent opportunity for your county to highlight effective county programs and raise public awareness and understanding about the various services provided to the community. Here are a few ideas on how to get started:

Establish A Planning Committee

The committee will plan, organize and coordinate all activities relating to NCGM. Committee members should include representatives from the county board, administration, school system and each county department. In addition, a public information officer or county official experienced in media relations should be included. Consider including a county extension service representative. This could be a staff member, 4-H volunteer or 4-H member. All areas of county government and schools should be involved in the planning process.

Decide How Extensive Your Activities Will Be

Plan activities throughout the month or organize just a few featured events. Hold fun, interactive and informative activities to reach different segments of your community including students, educators, senior citizens, young families, business leaders and community organizations. Activities should be designed to bring residents to county facilities such as the courthouse, parks, public safety building and recycling/waste transfer station. Activities can be planned to deploy county officials to locations where residents are already assembled. Suggestions for activities such as open houses and public tours are described elsewhere in this booklet.

Involve The Media

Be sure members of the local news media are aware of NCGM and the activities your committee has planned. Consider involving a member of the news media in the planning process. Media outreach tips are described elsewhere in this guide. The following pages will provide you and your planning committee several ideas on what to include in your county's celebration of NCGM.



COUNTIES MATTER

National County Government Month offers an opportunity to educate residents about county programs, services and responsibilities. It is also an opportunity to address misinformation about county government. In short, it's an opportunity to tell the public that **Counties Matter**.

As part of NCGM, prepare and distribute county fact sheets. Some counties roll out a “County Fact of the Day” or distribute fact sheets representing key county departments, such as public safety, parks and recreation, public works and health. Tell them things many residents do not know about county services, but need to know.

Send the fact sheets to the media, post them on the county website and distribute via social media. Fact sheets can highlight county services and programs provided by your county:

EMERGENCY RESPONSE, PUBLIC SAFETY AND JUSTICE

- How many trained emergency responders are employed by the county?
- How many trained volunteer emergency responders serve the county?
- How many emergency calls were responded to last year?
- How many bookings were processed at the county jail last year?
- What is the daily average jail population?

HEALTH & HOSPITALS

- How many patients were served last year at county hospitals and clinics?
- How many health department inspections were conducted last year?
- How many vaccinations were administered last year?
- How many emergency room visits were made last year?
- How many nursing homes are in the county?
- How many county residents have health insurance?

CHILDREN AND FAMILIES

- How many children, senior citizens or veterans received county services last year?

ECONOMY & EMPLOYMENT

- How many people are unemployed in the county?
- What is the average county wage?
- How many residents received direct job training or unemployment services last year?
- How many businesses have been added to the county? How many new jobs have they brought in?



OPEN THE COUNTY TO THE PUBLIC

A great way to educate residents about county services is getting them to visit county facilities for an open house or public tour.

HOLD AN OPEN HOUSE

Feature county departments showcasing the services provided. Arrange for county employees to be available to discuss the services. Schedule guided tours through the building. Use your local historical society or library to create presentations or displays to educate residents about the county's rich history. If the weather is nice, have the displays outside in the courtyard or a nearby parking lot. Have music, face painting, balloons, refreshments and entertainment for children. Make it a fun and interesting learning experience for the entire family.

OFFER TOURS

Schedule public tours at county facilities such as health facilities, parks, libraries, courts, recycling/waste transfer stations, and public safety buildings. Reach out to community groups, such as service clubs, 4-H and scouts and encourage them to come as a group to see how various county facilities operate.

BRING INFORMATION TO RESIDENTS

Hold public outreach events at the shopping mall, senior center, recreation center, county library or other location where people are expected to gather. Arrange to set up displays, provide county fact sheets and brochures and conduct presentations on county services. Work with the county extension service to spread the message about what counties do.

HOLD A JOBS FAIR

Highlight your county's workforce development and employment services at a "county jobs fair." Partner with the Chamber of Commerce and local businesses to educate job seekers about the skills and education local employers are looking for.

ENCOURAGE VOLUNTEERISM

Encourage residents to volunteer their time and talents to the community. Organize fellow county officials to spearhead a specific community service project and ask others to volunteer. Ask residents to volunteer their time to visit the elderly, disabled and ill in county hospitals and nursing homes. Ask residents to volunteer their services to assist area non-profit organizations such as those who serve veterans, seniors, juveniles, foster children, homeless persons, the mentally ill and domestic violence victims.



MAYOR AND COUNTY RECOGNITION DAY FOR NATIONAL SERVICE:

Every day, in counties across America, national service is tackling tough problems and strengthening communities. On April 4, 2017, as part of National County Government Month, county leaders are encouraged to recognize the impact of national service and thank those AmeriCorps members and Senior Corps volunteers who serve by participating in the Mayor and County Recognition Day for National Service.

APRIL 4, 2017

On this April 4, 2017, county executives, board chairs and board members, along with mayors and city officials will hold public events and highlight the impact of national service to the nation's counties and inspire more citizens to serve. Last year, 3,539 mayors and county leaders representing 178 million Americans participated in the day (including more than 850 county officials!). The initiative is being led by the National Association of Counties (NACo), the National League of Cities (NLC), Cities of Service and the Corporation for National and Community Service (CNCS).

As the federal agency for national service and volunteering, CNCS annually engages millions of citizens in service at more than 50,000 locations. Through AmeriCorps, Senior Corps, the Social Innovation Fund and other programs, CNCS leverages federal and private funds to support organizations that achieve measurable results where the need is greatest. Whether supporting food banks and homeless shelters, restoring parks, building homes, providing health services, strengthening public safety and juvenile justice services and managing community volunteers, national service members help local leaders tackle tough problems.

County governments have a broad range of responsibilities to residents, which matches CNCS's mission to improve lives, strengthen communities and foster civic engagement. A coordinated day of recognition presents a unique opportunity to spotlight the key role that national service and volunteering plays in helping counties solve problems. Participating in the day will highlight the impact of citizen service, show support for nonprofit and national service groups and inspire more residents to serve in their communities.

All county board chairs, board members, county executives and other county officials are encouraged to participate. Suggested activities include holding a thank you event, issuing a proclamation, visiting a national service program, joining a service project, taking a group photo with national service members and using social media to thank those who serve.

Contact: Tess Mason-Elder, CNCS Office of Government Relations • 202.606.6873 • tmason-elder@cns.gov. To learn more and sign up your county, visit www.nationalservice.gov/recognitionday.



SCHOOL INVOLVEMENT

Be sure to include schools in your National County Government Month activities to enable students to begin learning about county government.

COUNTIES WORK ONLINE GAME & COUNTY SOLUTIONS CLASSROOM CURRICULUM

As part of NCGM, NACo and our partner iCivics will unveil updated versions of our signature civic education tools for students – the Counties Work online educational game and the County Solutions classroom curriculum. The iCivics platform offers the nation's most comprehensive, standards-aligned civics curriculum available online for free.

The Counties Work educational game allows students to play the role of a county leader, fulfilling citizen requests and balancing community needs with limited resources. The County Solutions curriculum will be expanded to include high school instruction and leverage NACo's Counties Matter public awareness materials and our online interactive County Explorer data tool. We will also make available a classroom visitation guide for NACo members to discuss Counties Work and County Solutions with students and educators.

This national resource is an opportunity to educate students and the public about the role of your county in people's everyday lives.

PRESENTATIONS IN SCHOOLS

Plan visits to schools by various elected and appointed county officials. Discuss interesting historic facts about the county, such as famous residents or important events. Discuss how county government is structured and define its roles and responsibilities. Explain how the county works in conjunction with the state and federal government. Consider organizing a panel discussion with residents who have been positively affected by county programs. Make information on county government available to teachers to use in presentations or as part of their lesson plans.

CAREER DAY

Plan career days at local high schools. Share information about various occupations within county government such as sheriff deputies, police officers, social workers, nurses, court clerks, tax collectors, elections officials, parks and recreation employees, transportation department workers, librarians, corrections officers, firefighters and emergency dispatchers. Emphasize the essential services that these public servants provide each day to the community.

TOURS OF COUNTY FACILITIES

Encourage schools to set up tours of county offices and facilities. The approach should be part of a class lesson plan on government structure, the legislative process, public safety, healthcare and other services.

COUNTY OFFICIAL FOR A DAY

This is a popular activity for many students. High school students interested in government could be part of a program to become a county official for a day (i.e.: “shadow” a county official) and share the experience with other students.

CONTESTS

For younger students, sponsor a poster, essay or coloring contest involving the “Counties Moving America Forward: Transportation and Infrastructure are the Keys” theme or other county government theme.

LECTURES

Offer to teach a class at the community college or give a lecture. The topics could include healthcare, green government, economic development, technology, public safety, disaster preparedness, infrastructure and transportation or careers in county government.

DEBATES

Encourage college and high school students to address issues affecting local government through debates. Hold the debates in classrooms or as part of a high school assembly.

We're not just another pea in the pod.

Cooperative purchasing that is uniquely U.S. Communities.

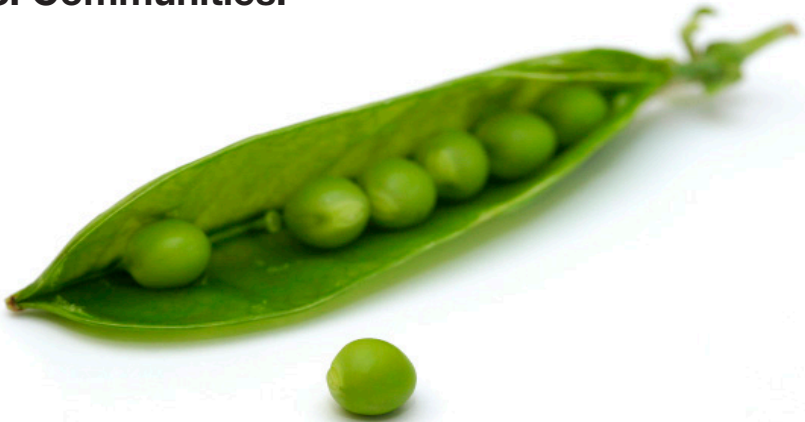

Founded by public agencies to represent your specific business interests, U.S. Communities has remained steadfast in its commitment to safeguard your ethical, legal and financial welfare at all times. It is the U.S. Communities difference that delivers savings, efficiency and value through:

- **Supplier commitments** to pricing, economy, sales and corporate support
- Solicitation, evaluation and award process led by an **independent lead public agency**
- Dedicated field **Program Managers** focused exclusively on public agency support

Experience the unmatched value of U.S. Communities.
Register today!

Visit us at www.uscommunities.org





MEETING WITH MEMBERS OF CONGRESS

Attachment: NCGM toolkit_2017 (1554 : National County Government Month - Proclamation)

National County Government Month is an ideal time to discuss national issues affecting county government with members of Congress who represent your county.

During NCGM, schedule a meeting with your congressional representative(s) or key staff in your congressional district office. Use the meeting to explain the great challenges facing your county and how Congress can help.

Many important issues are being debated nationally that affect counties. Be prepared with facts and information about how specific federal issues affect your county. Know where your member of Congress stands on important issues and on which committees he or she serves. Your message should be focused, compelling and relevant. To find out about NACo's 2017 Legislative Priorities (www.naco.org/2017LegPriorities) and obtain fact sheets on current national issues important to counties, visit the Legislation and Policy section of the website (naco.org/advocacy).

Contact: Deborah Cox • dcox@NACo.org • 202.942.4286

SAMPLE PROCLAMATION

National County Government Month - April 2017 “Brilliant Ideas at Work”

WHEREAS, the nation’s 3,069 counties serving more than 300 million Americans provide essential services to create healthy, safe and vibrant; and

WHEREAS, counties move America forward by providing health care, administering justice, keeping communities safe, creating economic opportunities and much more; and

WHEREAS, *INSERT YOUR COUNTY’S NAME*] and all counties take pride in their responsibility to protect and enhance the health, welfare and safety of its residents in efficient and cost-effective ways; and

WHEREAS, through National Association of Counties President Bryan Desloge’s “Brilliant Ideas at Work” initiative, NACo is encouraging counties to focus on the most innovative programs and services that strengthen communities; and

WHEREAS, in order to remain healthy, vibrant and safe, America’s counties provide public health, justice, safety, infrastructure, transportation, technology, environmental stewardship and economic services that play a key role in everything from residents’ daily commutes to emergency response; and

WHEREAS, each year since 1991 the National Association of Counties has encouraged counties across the country to actively promote their own programs and services to the public they serve; and

WHEREAS, *[INSERT COUNTY SPECIFIC INFO TO HIGHLIGHT]*

NOW, THEREFORE, BE IT RESOLVED THAT I, *[INSERT NAME & TITLE OF CHIEF ELECTED OFFICIAL]*, do hereby proclaim April 2017 as National County Government Month and encourage all county officials, employees, schools and residents to participate in county government celebration activities.

Contact: Lindsey Maggard • lmaggard@naco.org • 202.661.8824

MEDIA RESOURCES KIT

Be sure to check out the National County Government Month Media Resources Kit on the NACo website at www.naco.org/ncgm. This is your one-stop online shop for NCGM design templates to produce your county's own posters, banners, proclamations and news releases.

These additions are sure to enhance the festive atmosphere of your NCGM events. Each template is specially designed for the 2017 theme, "Brilliant Ideas at Work." Each template contains the NACo and NCGM logo. Plenty of space will be left available for you to add your county's logo or unique county government month slogan or message. If you find something you want to use, download the file onto a disc, add your county's local touch, and take the file to a local business to have the materials produced in the quantities you need.

Contact: David Jackson • djackson@naco.org • 202.942.4271





MEDIA RELATIONS STRATEGIES

Careful planning is essential to maximize public awareness of National County Government Month activities and the county services and programs you are highlighting. Here are effective ways to help secure positive news media coverage.

EDUCATE THE MEDIA

Inform local reporters, editors and broadcasters early and often about NCGM and your county's plans to celebrate it.

PLAN TO MAKE NEWS

Coordinate newsworthy events or announcements. You can launch new initiatives, announce plans for new programs or recognize county employees for their excellent public service. Keep in mind that newspapers seek in-depth facts, television stations want good visuals and radio reporters want snappy sounds bites. All reporters seek good stories. They want access to knowledgeable and articulate sources to make their stories interesting and informative.

PUBLISH A CALENDAR OF EVENTS

Publish a calendar of NCGM events on your county's website. Ask the local newspapers to publish the calendar. Ask the local television, cable and radio stations to air public service announcements about county services or events.

WRITE MEDIA ADVISORIES

Prepare and send media notices well in advance for specific NCGM events, such as the open house, tour of the hospital or visit to a local school. Describe who, what, where, when and why. Make it newsworthy.

WRITE NEWS RELEASES

Have news releases ready to distribute to the media the day of special NCGM events. Highlight what's new, beneficial and cost-effective. Use lively, concise quotes from appropriate county officials. Provide contact information.

TAKE YOUR MESSAGE TO THE MEDIA

Do not assume the news media will cover your events or announcements. Ask for a meeting with the newspaper's editorial board; volunteer to stop by the television station for an interview; be an in-studio guest on a local radio program. Be accessible, proactive and enthusiastic about county government and the services provided to the community.

SOCIAL MEDIA STRATEGIES

The emergence of social media in recent years provides tremendous opportunities to promote your NCGM events. If you already have a Facebook or Twitter account, use it to promote county government month activities. Coordinate a county government month “social media team” to plan social media outreach efforts.

ADDITIONAL RESOURCES

The NACo Media Relations Guide for Counties contains helpful tips on speaking with reporters, writing news releases, planning press conferences, and much more. Look for upcoming NACo webinars or workshops on media relations and social media strategies.

Contact: David Jackson • djackson@naco.org • 202.942.4271



2017 ACHIEVEMENT AWARDS

CELEBRATING 47 YEARS
OF INNOVATION

APPLY FOR THE 2017 ACHIEVEMENT AWARDS

Does your county have an innovative program that improves county government and enhances services for county residents? Apply for the 2017 Achievement Awards! There are 18 categories ranging from information technology, health, criminal justice, human services and many more.

By applying for the 2017 Achievement Awards, entries will be in the running for the Counties Matter Challenge: Brilliant Ideas at Work, NACo President Bryan Desloge's presidential initiative.

To begin your application visit:
www.naco.org/achievementawards

QUESTIONS?

Contact awards@naco.org

IMPORTANT DATES:

- SUBMISSIONS DEADLINE:
MARCH 27, 2017 AT 11:59 P.M. EDT
- NOTIFICATIONS OF
ACHIEVEMENT AWARDS:
WEEK OF APRIL 24, 2017
- NOTIFICATIONS OF COUNTIES
MATTER CHALLENGE:
WEEK OF MAY 29, 2017
- NACo ANNUAL CONFERENCE
AND EXPOSITION:
JULY 21 – 24, 2017

Attachment: NCGM toolkit_2017 (1554 : National County Government Month - Proclamation)

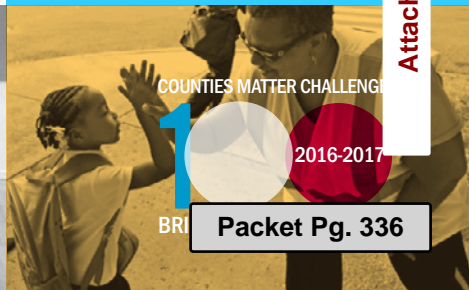

COUNTIES MATTER CHALLENGE

2016-2017

BRI

Packet Pg. 336

SAVE THE DATE

2017 NACo ANNUAL CONFERENCE
Franklin County, Ohio • July 21–24, 2017



Attachment: NCGM toolkit 2017 (1554 : National County Government Month - Proclamation)

COLUMBUS, OHIO
FRANKLIN COUNTY, OHIO
JULY 21-24 2017



NATIONAL ASSOCIATION OF COUNTIES
2017 ANNUAL CONFERENCE

SAMPLE NEWS RELEASE

INSERT YOUR COUNTY'S LETTERHEAD

CONTACT: Bea Candid
123/456-7890
bcandid@ablecounty.gov

Able County to Celebrate National County Government Month

Leaders to highlight county innovations in public health and safety, justice,
other county programs

Everytown, USA (April 1, 2017) – Able County will celebrate National County Government Month (NCGM) during the month of April to showcase how the county is building a healthy, vibrant and safe community through innovative efforts in managing justice and public safety systems, fostering conditions for economic growth, strengthening infrastructure and pursuing many other efforts to improve residents' quality of life.

The theme for this year's celebration of NCGM is "Brilliant Ideas at Work," showcasing how counties are trailblazing new approaches to seize opportunities and overcome community challenges.

Featured NCGM events include public tours of Able County's most recent economic development projects. Commissioners and department heads will visit local jails and hospitals throughout the month of April. The popular "Able County Family Day" will be held on xxx, 2017, which will showcase essential county programs and services.

"Able County is proud of the programs and services provided to our residents," said Board Chair Tim Timmons. "Our efforts combined with efforts of counties across the country are helping American communities to thrive. I encourage all county residents to take advantage of National County Government Month outreach events to learn how the county can assist you and your loved ones."

Since 1991 the National Association of Counties (NACo) has encouraged counties across the country to raise public awareness and understanding about the roles and responsibilities of counties.

Able County NCGM public events include:

[INSERT COUNTY SPECIFIC INFO TO HIGHLIGHT].

A full listing of NCGM events is available at: www.ablecounty.gov.

Contact: David Jackson • djackson@naco.org • 202.942.4271



Attachment: NCGM toolkit_2017 (1554 : National County Government Month - Proclamation)

NACo PROGRAMS HELP COUNTIES HELP COMMUNITIES

The National Association of Counties has many programs and initiatives available to assist counties.

If your county participates in any of NACo's programs, National County Government Month is an excellent opportunity to inform the public about them. If your county does not participate in any of these programs, consider involving your county in one or more of NACo's programs and announce it during NCGM.

U.S. COMMUNITIES COOPERATIVE PURCHASING PROGRAM

U.S. Communities, founded in 1996, is the leading national government purchasing cooperative, providing world class government procurement resources and solutions to local and state government agencies, school districts (K-12), higher education institutes and nonprofits looking for the best overall supplier government pricing. The program offers:

- No costs or fees to participate
- Access to the best overall supplier government pricing by combining the potential cooperative purchasing power of up to 90,000 public agencies
- Access to thousands of the best brands available in a wide variety of categories, services and solutions, and
- Oversight by public purchasing professionals who ensure that program pricing commitments are met.

Contact: Sharon Russell • srussell@naco.org • 202.942.4222

NACo DEFERRED COMPENSATION PROGRAM

Through our partnership with Nationwide Retirement Solutions, NACo's Defined Contribution and Retirement Services Program offers county employees a voluntary, 457b tax-deferred savings opportunity that supplements employer sponsored retirement plans. It also offers (401)a match and stand-alone defined contribution plans. The program is endorsed by 40 state associations, and more than 3,000 counties and county jurisdictions participate. We have helped more than 1.5 million county employees and retirees save accumulated assets of more than \$15 billion.

Contact: Carlos Greene, cgreene@naco.org, 404.263.3656

ECONNECTDIRECT®

NACo has partnered with Multi-Bank Securities, Inc. (MBS) endorsing eConnectDirect® as an essential tool for members to manage their fixed-income investment needs. This proprietary tool gives county treasurers visibility to thousands of fixed-income offerings in a market with little transparency. It arms investors with the necessary tools and confidence to select and transact within the fixed-income marketplace. Currently, 14 state associations endorse this program as a resourceful tool for county treasurers.

Contact: David Thompson • dthompson@naco.org • 202.942.4240

PUBLIC FINANCE AUTHORITY

The Public Finance Authority (PFA) partners with local governments to assist in the financing of public benefit projects that create temporary and permanent jobs, affordable housing, community infrastructure and improve the overall quality of life in local communities. PFA offers accelerated economic development opportunities and cost effective financing in all 50 states.

Contact: David Thompson • dthompson@naco.org • 202.942.4240

SMART JUSTICE INITIATIVE

The Smart Justice Initiative aims to build knowledge and capacity for successful justice policies and practices among the nation's counties and provide a closer examination of the need for intergovernmental collaboration and public private partnerships in an effort to create safer communities and spend taxpayer money more effectively. Issues include pre-trial services, post-release service coordination, justice and mental health collaboration, supportive housing, and employment.

Contact: Maeghan Gilmore • mgilmore@NACo.org • 202.942.4261

NACo PRESCRIPTION, HEALTH AND DENTAL DISCOUNT PROGRAM

The NACo Live Healthy: Prescription, Dental & Health Discount Program provides relief to uninsured and underinsured Americans who face high prescription, health and dental costs. The program is free to NACo member counties and it has provided over \$630 million in savings to county residents across the country since 2004. The program, which is administered by CVS/caremark, includes discounts on prescriptions, vision care, LASIK & PRK vision procedures, hearing aids & screenings, prepaid lab work, prepaid diagnostic imaging, diabetic supplies and dental care.

BENEFITS TO COUNTIES AND RESIDENTS

- Everyone is accepted
- Individual prescription savings of up to 75 percent and overall average savings of 24 percent.
- Savings of 15 – 70% for residents on the additional health services
- A network of 68,000+ pharmacies nationwide that accept the discount card, including both local pharmacies and national chains
- 110,000 dentists, 54,000 optometrists and 8,000 ophthalmologists accept the discount card nationally
- Save 15% to 50% on most dental procedures
- A marketing reimbursement fee option can earn the county \$1 every time a resident uses the prescription card to save money

The program is FREE for member counties and inexpensive for residents:

- Prescription Drug Discount Card: Free for Residents
- Dental Discount Program: \$6.95 month or \$69 year for individuals. \$8.95 month or \$79 year for families
- Medical Services: \$6.95 month or \$69 year for individuals. \$8.95 month or \$79 year for families

Counties benefit from the program by being able to offer their residents an affordable alternative to paying full price for health care. Residents benefit from the program by saving on auxiliary health care services that are not currently included in the Affordable Care Act. To sign up and get more information please visit www.naco.org/health.

Contact: Andrew Goldschmidt • agoldsch@NACo.org • 202.942.4221

COMMUNITY AND ECONOMIC DEVELOPMENT

To help counties implement innovative and effective local programs, NACo provides members with information, trainings and assistance to engage counties and their multi-sector partners who are bound by a common interest in growing stronger, more competitive, more equitable counties and communities. The **Community and Economic Development** practice area supports county leaders seeking to develop and implement creative, innovative, locally driven strategies that will foster economic growth and ensure long-term county resiliency.

Topics within this practice area include:

- economic visioning and diversification
- entrepreneurship and small business development
- workforce development
- infrastructure and transportation investments
- land use planning
- water resource protection and restoration
- energy management
- disaster mitigation, preparedness and response, and eco-efficient purchasing and facility management.

Contact: Sanah Baig • sbaig@NACo.org • 202.661.8807



LIVE HEALTHY U.S. COUNTIES

The exclusive prescription, dental and health discounts program free to NACo member counties

For more information, call 888.407.NACo (6226) or email us at membership@naco.org



HEALTHY COUNTIES INITIATIVE

NACo's Healthy Counties Initiative creates and sustains healthy counties by supporting collaboration and sharing innovative approaches to pressing health issues. An advisory board, comprised of county leaders and corporate partners, identifies priorities and ensures that other county leaders receive timely information to make appropriate health decisions for counties.

Healthy Counties focuses on enhancing:

- Public-private partnerships in local health delivery
- Access to, and coordination of, care for vulnerable populations in the community, including through health services in hospitals, community health centers and county jails, while concentrating on cost-containment strategies, and
- Community public health and behavioral health programs.

By addressing these and other relevant topics, Healthy Counties empowers county leaders with resources for promoting and advancing health policies and programs that meet the needs of their residents and employees. County leaders and corporate partners collaborate, share efficient and effective solutions and build healthy counties through educational forums, workshops, webinars, peer exchanges and publications.

JOIN US FOR COUNTY HEALTH DAY!

On **April 19, 2017**, County Health Day will highlight how counties build healthier communities and will emphasize counties' role in health – including supporting health care delivery, public health, behavioral health and Medicaid. Throughout the day and during National County Government Month, NACo will post stories showcasing county accomplishments and share health tools and resources.

As part of NACo's partnership with the Robert Wood Johnson Foundation, NACo will promote the principles of the County Health Rankings & Roadmaps framework and encourage counties to review their County Health Ranking. NACo will also host a Twitter chat to spur further dialogue about county health and conduct a webinar to spotlight tools, resources and county examples.

Contact: Michelle Price • mprice@NACo.org • 202.942.4267



TELL US ABOUT YOUR PROGRAM

Attachment: NCGM toolkit_2017 (1554 : National County Government Month - Proclamation)

Thank you for your interest in celebrating National County Government Month! NACo wants to know what activities and programs you have planned so we can share this information with other counties to help them have successful NCGM celebrations. Please use the online form on the NACo website or e-mail your activities to David Jackson at djackson@naco.org. Be sure to send NACo your proclamations, photos and videos of your county's celebrations. Those files can be uploaded via the online form as well or sent directly to Brian Namey.

If your county is on social media, please share your activities, photos and proclamations directly on NACo's Facebook Page at www.facebook.com/NACoDC or on Twitter at www.twitter.com/NACoTweets using the hashtag #NCGM.

Thank you for your commitment to county government!





fb.com/NACoDC
 @NACoTweets
 youtube.com/NACoVideo
 linkedin.com/in/NACoDC



8.G.2

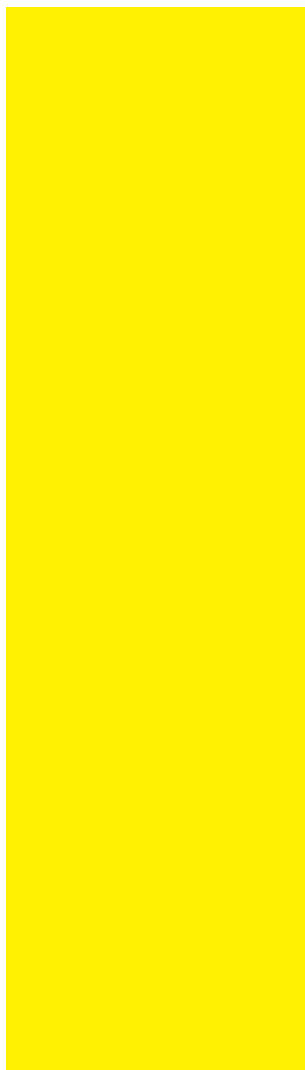

Attachment: NCGM toolkit_2017 (1554 : National County Government Month - Proclamation)



660 NORTH CAPITOL STREET NW
 SUITE 400 • WASHINGTON, D.C. 20001
 202.393.6226 • www.NACo.org

Packet Pg. 347



Board of Commissioners
AGENDA ITEM SUMMARY SHEET

Consent Agenda

Item Number: 8.H
Meeting Date: March 06, 2017

Submitted By: Angela Wooten, Clerk to the Board
Administration
Prepared by: Angela Wooten

Item Title **Proclamation: American Red Cross Month 2017**

Attachments: Proclamation AMERICAN RED CROSS MONTH
2017.docx (DOCX)

Summary:

Recommendation:

AMERICAN RED CROSS MONTH 2017

A Proclamation

In Camden County, we have a long history of helping our neighbors in need. American Red Cross Month is a special time to recognize and thank our heroes – those Red Cross volunteers and donors who give of their time and resources to help community members.

These heroes help families find shelter after a home fire. They give blood to help trauma victims and cancer patients. They deliver comfort items to military members in the hospital. They use their lifesaving skills to save someone from a heart attack, drowning or choking. They enable children around the globe to be vaccinated against measles and rubella.

The American Red Cross depends on local heroes to deliver help and hope during a disaster. We applaud our heroes here in Camden County who give of themselves to assist their neighbors when they need a helping hand.

Across the country and around the world, the American Red Cross responds to disasters big and small. In fact, every eight minutes the organization responds to a community disaster, providing shelter, food, emotional support and other necessities to those affected. It collects nearly 40 percent of the nation’s blood supply; provides 24-hour support to military members, veterans and their families; teaches millions lifesaving skills, such as lifeguarding and CPR; and through its Restoring Family Links program, connects family members separated by crisis, conflict or migration.

We dedicate the month of March to all those who support the American Red Cross mission to prevent and alleviate human suffering in the face of emergencies. Our community depends on the American Red Cross, which relies on donations of time, money and blood to fulfill its humanitarian mission.

NOW, THEREFORE, I, Clayton D. Riggs, Chairman of Camden County, by virtue of the authority vested in me by the Constitution and laws of Camden County and North Carolina do hereby proclaim March 2017 as American Red Cross Month. I encourage all Americans to support this organization and its noble humanitarian mission.

IN WITNESS WHEREOF, I have hereunto set my hand this 6th day of March, in the year of our Lord two thousand seventeen, and of Camden County, North Carolina.

Clayton D. Riggs, Chairman
Board of Commissioners

ATTEST: _____
Angela Wooten
Clerk to the Board

Attachment: Proclamation AMERICAN RED CROSS MONTH 2017.docx (1566 : Proclamation: American Red Cross Month 2017)



Board of Commissioners
AGENDA ITEM SUMMARY SHEET

County Manager's Report

Item Number: 10.A
Meeting Date: March 06, 2017
Submitted By: Michael Brillhart, County Manager
Administration
Prepared by: Angela Wooten

Item Title **RFQ for Construction Manager at Risk (CMR) Services**

Attachments:

Summary:

An RFQ for Construction Manager at Risk (CMR) Services was advertised specific to the construction of a new county Public Services Building. The county received three (3) proposals. Each met the qualification requirements within the RFQ. Based upon a review of each proposal by members of the Selection Committee, staff scored the firms according to the posted selection criteria.

CMR Initial Criteria from RFQ Announcement:

1. Proposer's relevant past experience in providing CMR or similar services for similar projects;
2. Key Team Members' qualifications and relevant experience
3. Current workload of firm's personnel.
4. Project quality control plan including recent experience with GMP, cost control, change orders, and maintaining design and construction schedules.
5. Record of successfully completed projects without major legal or technical problems.
6. Experience in Public bidding
7. Experience with USDA funding
8. Experience working on projects utilizing Construction Management at Risk construction delivery method
9. Public Facility Projects understanding, methodology and approach;
10. Familiarity with local conditions and codes as evidenced in previous projects;
11. References
12. Quality, completeness and readability of SOQ package
13. Other factors that may be appropriate for the project.
14. (50%) Minority/Women Owned Business.



Scoring:

Firm	Total Score
M. B. Kahn	60
A. R. Chesson	58
Sussex	35

Recommendation:

The highest scoring firm was M.B. Kahn Construction Company. In accordance with the state mandated RFQ process, the next step is to conduct negotiations with the highest scoring firm for the proposed fee for services. With board approval, staff will commence with the necessary steps for securing M.B. Kahn Construction Company's proposal for services.

Motion to accept staff's recommendation and allow staff to commence with the necessary steps for securing VIA Design Architects' proposal for services.



Board of Commissioners
AGENDA ITEM SUMMARY SHEET

Information, Reports & Minutes From Other Agencies

Item Number: 11.A
Meeting Date: March 06, 2017

Submitted By: Krystal Lancaster, Librarian
Library
Prepared by: Krystal Lancaster

Item Title **January 2017 Library Statistics**

Attachments: 17_01 BOC Stats (PDF)

Summary:

Recommendation:

Camden County Public Library January 1-31, 2017 Statistics

- **Visitor Count:** 1695
- **Days/Hours Open:** 26/232
- **# Items in Collection:** 14,690(Opening Day Collection # Items = 4,755)
- **Total Check Outs/Renewals:** 3,884
- **Library Card Holders:** 2,783
- **Computer/ Wireless Use:** 855/516
- **Juvenile Programs :** 10 programs /145 attendance
- **Adult Programs :** 2 programs / 7 attendance
- **Meeting Room:** 12 reservations /125 attendance

Comparison by Year

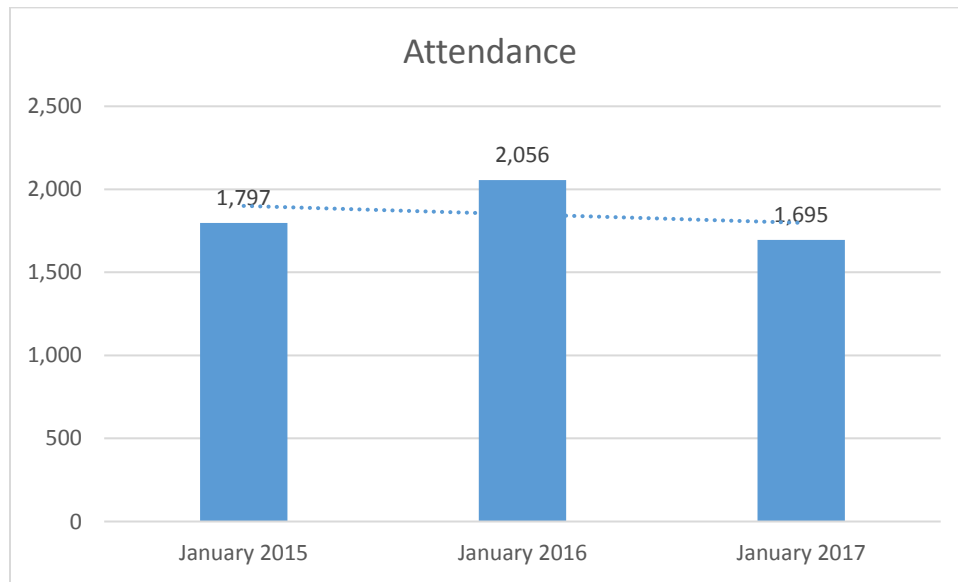

Daily attendance for January compared by year (2015-2017).

Attachment: 17_01 BOC Stats (1581 : January 2017 Library Statistics)

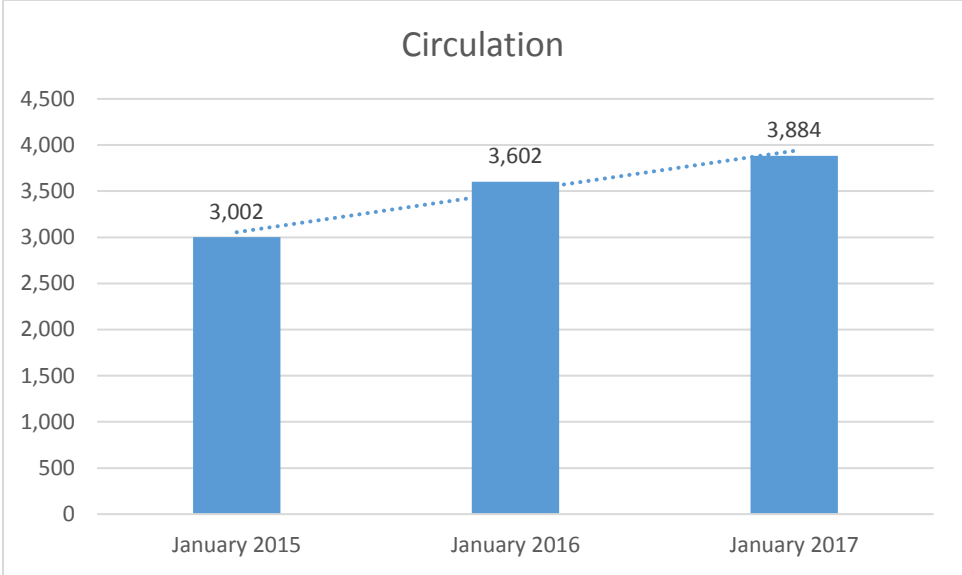

Number of library materials checked out for January compared by year (2015-2017).



Board of Commissioners
AGENDA ITEM SUMMARY SHEET

Information, Reports & Minutes From Other Agencies

Item Number: 11.B
Meeting Date: March 06, 2017

Submitted By: Angela Wooten, Clerk to the Board
Administration
Prepared by: Angela Wooten

Item Title **EMS Reports**

Attachments: Microsoft Word - 2017 01 EMS Board Minutes.docx (PDF)
Jan Monthly Report FY 2017.pdf (PDF)
Jan Monthly Report FY 2017.pdf (PDF)
Microsoft Word - Agenda.doc (PDF)
Microsoft Word - Annoucement.doc (PDF)

Summary:

Recommendation:

**Monthly Report
for
January 2017**

Ambulance Responses:	MTD 2016-2017	MTD 2015-2016	YTD 2016-2017	YTD 2015-2016		
Total Responses	1045	927	6707	6853		
Camden County	50	62	401	456		
Blackwater	0	0	0	0		
Pasquotank County	759	648	4805	4927		
Albemarle Hospital	236	217	1501	1470		
Advanced Life Support	306	295	2087	2145	Inter-Facility Transports	<u>LYTD</u>
Basic Life Support	495	411	3008	3145		<u>INT-TRNS</u>
Treatment/No Tx	10	5	44	40	91	97
Patient Refusal	125	104	787	721		
Cancelled Enroute	37	38	287	321	Non-Emergency Transports	<u>LYTD</u>
Standby-Event	3	1	44	41		<u>NON-EMR</u>
Standby-Helo	0	0	1	0	260	225
Standby-Fire	15	7	79	65		
Mutual Aid	1	1	13	5		
Miscellaneous	53	65	356	370		
	1045	927	6707	6853		

Accounts Receivable:	MTD	YTD	LYYTD
A/R Beginning Balance	\$ 1,968,282.91 +		
Patient Billings	\$ 442,628.30 +	\$ 2,906,685.10	\$ 2,973,908.80
Refunds	\$ 2,517.72 +	\$ 14,900.66	\$ 15,703.80
Patient Credits	\$ 232,109.78 -	\$ 1,600,035.25	\$ 1,686,853.27
Ins. Contract Adj.	\$ 121,514.41 -	\$ 831,816.33	\$ 850,454.88
Write Off's	\$ 39,963.17 -	\$ 175,754.74	\$ 195,816.18
Late PCR's			
Adjustment	\$ (363.92) +		
A/R Ending Balance	\$ 2,019,477.65	LYMTD	\$ 1,927,162.45
Deposits to Finance Office	\$ 158,558.07 +	\$ 157,520.02	
Recovery from Bad Debt	\$ 791.57 -		
Misc. Revenue	\$ 329.08 -		
A/R Payment to Finance	\$ 74,672.36 +	<u>Notes:</u>	
Adjustment Added			
Adjustment Subtracted			
Total	\$ 232,109.78		

Attachment: Microsoft Word - 2017 01 EMS Board Minutes.docx (1552 : EMS Reports)

**Monthly Report
for
January 2017**

Ambulance Responses:	MTD 2016-2017	MTD 2015-2016	YTD 2016-2017	YTD 2015-2016		
Total Responses	1045	927	6707	6853		
Camden County	50	62	401	456		
Blackwater	0	0	0	0		
Pasquotank County	759	648	4805	4927		
Albemarle Hospital	236	217	1501	1470		
Advanced Life Support	306	295	2087	2145	Inter-Facility Transports	<u>LYTD</u>
Basic Life Support	495	411	3008	3145		<u>INT-TRNS</u>
Treatment/No Tx	10	5	44	40	91	97
Patient Refusal	125	104	787	721		
Cancelled Enroute	37	38	287	321	Non-Emergency Transports	<u>LYTD</u>
Standby-Event	3	1	44	41		<u>NON-EMR</u>
Standby-Helo	0	0	1	0	260	225
Standby-Fire	15	7	79	65		
Mutual Aid	1	1	13	5		
Miscellaneous	53	65	356	370		
	1045	927	6707	6853		

Accounts Receivable:	MTD	YTD	LYYTD
A/R Beginning Balance	\$ 1,968,282.91 +		
Patient Billings	\$ 442,628.30 +	\$ 2,906,685.10	\$ 2,973,908.80
Refunds	\$ 2,517.72 +	\$ 14,900.66	\$ 15,703.80
Patient Credits	\$ 232,109.78 -	\$ 1,600,035.25	\$ 1,686,853.27
Ins. Contract Adj.	\$ 121,514.41 -	\$ 831,816.33	\$ 850,454.88
Write Off's	\$ 39,963.17 -	\$ 175,754.74	\$ 195,816.18
Late PCR's			
Adjustment	\$ (363.92) +		
A/R Ending Balance	\$ 2,019,477.65	LYMTD	\$ 1,927,162.45
Deposits to Finance Office	\$ 158,558.07 +	\$ 157,520.02	
Recovery from Bad Debt	\$ 791.57 -		
Misc. Revenue	\$ 329.08 -		
A/R Payment to Finance	\$ 74,672.36 +		
Adjustment Added			
Adjustment Subtracted			
Total	\$ 232,109.78		

Notes:

Attachment: Jan Monthly Report FY 2017.pdf (1552 : EMS Reports)

**Monthly Report
for
January 2017**

Ambulance Responses:	MTD 2016-2017	MTD 2015-2016	YTD 2016-2017	YTD 2015-2016		
Total Responses	1045	927	6707	6853		
Camden County	50	62	401	456		
Blackwater	0	0	0	0		
Pasquotank County	759	648	4805	4927		
Albemarle Hospital	236	217	1501	1470		
Advanced Life Support	306	295	2087	2145	Inter-Facility	<u>LYTD</u>
Basic Life Support	495	411	3008	3145	Transports	<u>INT-TRNS</u>
Treatment/No Tx	10	5	44	40	91	97
Patient Refusal	125	104	787	721		
Cancelled Enroute	37	38	287	321	Non-Emergency	<u>LYTD</u>
Standby-Event	3	1	44	41	Transports	<u>NON-EMR</u>
Standby-Helo	0	0	1	0	260	225
Standby-Fire	15	7	79	65		
Mutual Aid	1	1	13	5		
Miscellaneous	53	65	356	370		
	1045	927	6707	6853		

Accounts Receivable:	MTD	YTD	LYYTD
A/R Beginning Balance	\$ 1,968,282.91 +		
Patient Billings	\$ 442,628.30 +	\$ 2,906,685.10	\$ 2,973,908.80
Refunds	\$ 2,517.72 +	\$ 14,900.66	\$ 15,703.80
Patient Credits	\$ 232,109.78 -	\$ 1,600,035.25	\$ 1,686,853.27
Ins. Contract Adj.	\$ 121,514.41 -	\$ 831,816.33	\$ 850,454.88
Write Off's	\$ 39,963.17 -	\$ 175,754.74	\$ 195,816.18
Late PCR's			
Adjustment	\$ (363.92) +		
A/R Ending Balance	\$ 2,019,477.65	LYMTD	\$ 1,927,162.45
Deposits to Finance Office	\$ 158,558.07 +	\$ 157,520.02	
Recovery from Bad Debt	\$ 791.57 -		
Misc. Revenue	\$ 329.08 -		
A/R Payment to Finance	\$ 74,672.36 +	<u>Notes:</u>	
Adjustment Added			
Adjustment Subtracted			
Total	\$ 232,109.78		

Attachment: Jan Monthly Report FY 2017.pdf (1552 : EMS Reports)

Emergency Medical Services Board Agenda

February 8, 2017

- Approval of Minutes
- EMS Nurse Liaison's Report
- Rescue Squad Report
- EMS Department Report
- Medical Director's Report
- County Manager's Report
 - Pasquotank County
 - Camden County
- New Business
- Closed Session
- Adjournment

Memorandum

Date: February 3, 2017

From: Jerry Newell
EMS Director

To: All EMS Board Members

Re: Notification of Next Scheduled Business Meeting

The next scheduled meeting of the Pasquotank-Camden Emergency Medical Services Board will be Wednesday, February 8, 2017, at 2:00 p.m. It will be held at the Pasquotank-Camden EMS Administration Building, Elizabeth City. The minutes from the January 2017 meeting are enclosed for your review.

Please call me if you will be unable to attend.

JN/lis



Board of Commissioners
AGENDA ITEM SUMMARY SHEET

Information, Reports & Minutes From Other Agencies

Item Number: 11.C
Meeting Date: March 06, 2017
Submitted By: Angela Wooten, Clerk to the Board
Administration
Prepared by: Angela Wooten

Item Title **ARPO Transportation Update**

Attachments: mhtml:file://C:\Users\awooten\AppData\Local\Microsoft\Windows\T
(PDF)

Summary:

ARPO Transportation Update

Recommendation:



Albemarle Rural Planning Organization Transportation Update

New this week

The N.C. Department of Transportation is now accepting applications from communities interested in participating in the Watch for Me NC 2017 program.

Watch for Me NC is a nationally recognized bicycle and pedestrian safety, education, and enforcement program. It uses a comprehensive and data-driven approach to increase public awareness and expand local capacity to improve bicycle and pedestrian safety.

The program is seeking new communities in North Carolina looking to help address pedestrian and bicycle safety. Interested communities can learn more about the program or download an application on the [Watch for Me NC website](#). Applications are due March 24, 2017.

Communities selected to participate will receive free law enforcement training, technical assistance and safety materials to support their local efforts. Safety materials include bicycle lights, reflective arm bands, bumper stickers, brochures, posters and banners that have pedestrian and bicycle safety messages. English and Spanish materials are available. Each community will also be eligible to receive advertising such as billboards, transit ads and public service announcements paid for by NCDOT. Applicants must demonstrate support from local law enforcement agencies such as local government and campus police and the capacity to participate fully in the program.

NCDOT will host a webinar for prospective applicants at 1 p.m. on February 21 to inform communities about the program, its requirements and the application process. Registration is available [online](#). The webinar will also be recorded and posted to the Watch for Me NC website. Interested applicants are strongly encouraged to view the webinar.

Governor Cooper has submitted a list of over 400 "shovel ready" N.C. Highway projects to the Trump Administration to be considered for federal funding. The press release, [here](#), only speaks to eight projects and we are unsure if any ARPO projects are on the list submitted by Governor Cooper. Once we find out ore information, we will let you know.

[Here](#) is a link to the Small Town and Rural Design Guide for biking and walking which was created by Alta Planning and Design. for a guide already have seen this but this is nice guide to rural bike/ped infrastructure from Alta.

Transportation Bills

[STI/Regional & Division Weighting](#) - House- Filed 2/9/17

[DOT/DMV changes](#) - House- Filed 2/15/17 and Senate filed 1/25/17

Reminders

The ARPO will be offering the Bicycle and Pedestrian mini-grant, again, this year. More information on the grant opportunity can be found [here](#).

News previously reported on

The ARPO RTCC and RTAC Boards met on Wednesday January 25, 2017.

1. [Here](#) is the agenda summary for the meetings.
2. [Here](#) is a resolution, adopted by the RTAC Board, regarding the STI law.
3. [Here](#) is the ARPO's 2017 Legislative Agenda which was adopted by the RTAC Board.
4. [Here](#) is a letter from the RTAC Board regarding the recommendation in the House Select Committee on Strategic Transportation Planning and Long term Funding Solutions Draft report (Representatives Steinburg, Boswell, and Hunter as well as Senators Smith-Ingram and Cook all received the letter)

We have not yet heard who will be replacing Ed Goodwin as the Director of the N.C. Ferry Division. Jed Dixon has been named as the Acting Director.

We have not been notified as to who will be replacing our Board of Transportation Division 1 member, Malcolm Fearing, yet.

On January 26-27, I attended the RPO Quarterly meeting in Fayetteville. John Coggin, the Director of Advocacy for the Rural Center gave a presentation which may be of interest to you. The presentation is located [here](#).

[Here](#) is the Albemarle RPO supplement to the [Draft](#) 2018-2027 STIP. The supplement includes year-by-year funding tables listing projects that are funded for feasibility study, planning/design, right of way or construction sometime within the 2018-2027 time frame for just the Albemarle RPO region.

Projects have been grouped by mode. Highway (road) projects being listed first, followed by aviation, bicycle/pedestrian, ferry, rail, and public transportation. The projects in the highway section are ordered by program

(e.g. Interstate, then rural, urban, bridge, safety, and congestion mitigation). Within the I, R, U, and B programs, the order is more or less by route (e.g. Interstate, then US, then NC, then SR, then "new routes", etc.).

Budget modifications, project cost increases, delivery schedule reviews and other factors will probably result in some programming changes prior to adoption of a final STIP late next spring. Hopefully any changes will be minor, but there are no guarantees.

Here is the Draft plan which includes projects throughout the entire state.



ARPO Board meetings

January 25, 2017 - Manteo
April 26, 2017- Elizabeth City
July 26, 2017 - Manteo
October 25, 2017- Elizabeth City

Who we are and what we do

RPO's provide a forum for state and local officials to discuss and address issues requiring regional solutions. We are funded by the state with an additional required 20% local match and provide these core services: Coordinate, assist and develop local and regional plans, provide a forum for public participation in the transportation planning and implementation process, develop and prioritize projects the organization believes should be included in the state transportation improvement program and provide transportation related information to local governments.



Share

Our mailing address is:

Albemarle Rural Planning Organization

Angela M. Welsh, ARPO Director

512 South Church Street

Hertford, NC 27944

** Material contained in this update may be from a number of electronic and print sources. The views and opinions expressed by other organizations or outside publications do not necessarily reflect the policies or views of the Albemarle Rural Planning Organization or its members.**

Copyright © 2016 Albemarle Rural Planning Organization, All rights reserved.

Want to change how you receive these emails?

You can [update your preferences](#) or [unsubscribe from this list](#)

This email was sent to Awooten@camdencountync.gov
[why did I get this?](#) [unsubscribe from this list](#) [update subscription preferences](#)
Albemarle Rural Planning Organization · 512 South Church Street · Hertford, NC 27944 · USA



Attachment: mhtml:file://C:\Users\awooten\AppData\Local\Microsoft\Windows\T (1570 : ARPO Transportation Update)



Board of Commissioners
AGENDA ITEM SUMMARY SHEET

Information, Reports & Minutes From Other Agencies

Item Number: 11.D
Meeting Date: March 06, 2017

Submitted By: Angela Wooten, Clerk to the Board
Administration
Prepared by: Angela Wooten

Item Title **National Association of Counties**

Attachments: National Association of Counties (PDF)

Summary:

CERTIFICATE OF MEMBERSHIP

NATIONAL ASSOCIATION OF COUNTIES

presents this Certificate of Membership to

Camden County, NC



Bryan Desloge
NACo President

Matthew D. Chase
Executive Director



NACo Membership Year 2017



CAMDENCOUNTY

new energy. new vision.

Board of Commissioners AGENDA ITEM SUMMARY SHEET

Information, Reports & Minutes From Other Agencies

Item Number: 11.E
Meeting Date: March 06, 2017

Submitted By: Angela Wooten, Clerk to the Board
Administration
Prepared by: Angela Wooten

Item Title **March for Meals**

Attachments: March for Meals (PDF)

Summary:

Recommendation:



February 8, 2017

Michael Brillhart
PO Box 190
Camden, NC 27921

Dear Mr. Brillhart:

I am writing you on behalf of the 1,100 seniors we serve in Camden, Chowan, Currituck, Dare, Gates, Hyde, Pasquotank, Perquimans, Tyrrell and Washington Counties to invite you to participate in the 15th annual March for Meals. As a prominent figure in **Camden County**, you are in an excellent position to help the Albemarle Commission Senior Nutrition Program raise awareness for the growing number of seniors facing hunger and isolation, both serious problems currently impacting our community and the nation at large.

The Albemarle Commission Senior Nutrition Program participates in the national March for Meals campaign, which is an annual month-long event, led by Meals on Wheels America. It is designed to generate public awareness about senior hunger and isolation and to celebrate the invaluable services provided by the Meals on Wheels programs – both home-delivered and congregate – in virtually every community across the country. Given the exemplary public-private partnership Meals on Wheels embodies, this annual campaign is also intended to showcase the successes of the Older Americans Act, help recruit new volunteers from our community and to increase fundraising from local businesses and supporters. For more information, please visit www.marchformeals.com.

We would be honored if you could participate in the March for Meals campaign by helping to prepare and/or deliver meals to our senior clients during the month of March 2017. In doing so, you can connect with vulnerable seniors in our community and help the Albemarle Commission Senior Nutrition Program gain much-needed visibility for this cause. We also host our annual Community Champions Week March 20 - 24 that you are welcome to join if your busy schedule allows.

If you are interested in joining the Albemarle Commission Senior Nutrition Program for March for Meals, please contact us at your earliest convenience. I would be delighted to answer any questions that you may have and can be reached at 252-426-5753 ext224 or lalvarico@accog.org. Thank you for your serious consideration of our request. I look forward to hearing from you.

Sincerely,

Laura Alvarico
Director, Albemarle Commission Area Agency on Aging



CAMDENCOUNTY

new energy. new vision.

Board of Commissioners AGENDA ITEM SUMMARY SHEET

Information, Reports & Minutes From Other Agencies

Item Number: 11.F
Meeting Date: March 06, 2017

Submitted By: Stephanie Humphries, Finance Director
Finance
Prepared by: Stephanie Humphries

Item Title **FY 16-17 Sales Tax Revenue Collections**

Attachments: Sales tax collections 16-17 (PDF)

Summary: Sales Tax Revenue Collections

Recommendation: N/A

SALES TAX REVENUE COLLECTION REPORT

FY 2016-2017 22-Feb-

SALES TAX - GENERAL FUND														
	July	August	September	October	November	December	January	February	March	April	May	June	Totals	Budgeted
Art. 39	\$44,906	\$29,261	\$44,167	\$43,630	\$42,588	\$45,332							\$249,884	\$590,000
Art. 40	\$21,885	\$18,599	\$23,046	\$22,644	\$21,924	\$23,487							\$131,585	\$275,000
Art. 42	\$10,593	\$11,516	\$14,125	\$14,030	\$13,752	\$14,383							\$78,400	\$145,000
Art. 44	\$0	\$1	\$0	\$0	\$0	\$0							\$1	\$0
Total	\$77,384	\$59,378	\$81,339	\$80,304	\$78,264	\$83,202	\$0	\$0	\$0	\$0	\$0	\$0	\$459,871	
													Total Budgeted	\$1,010,000

SALES TAX REVENUE- RESTRICTED SCHOOL CAPITAL RESERVE FUND														
	July	August	September	October	November	December	January	February	March	April	May	June	Totals	Budgeted
Art. 40	\$17,986	\$13,725	\$14,801	\$14,062	\$14,970	\$14,970							\$90,513	\$185,000
Art. 42	\$35,972	\$27,449	\$29,601	\$28,123	\$28,123	\$29,941							\$179,210	\$360,000
Total	\$53,958	\$41,174	\$44,402	\$42,185	\$43,094	\$44,911	\$0	\$0	\$0	\$0	\$0	\$0	\$269,723	
													Total Budgeted	\$545,000
Grand	\$131,342	\$100,552	\$125,741	\$122,488	\$121,358	\$128,113	\$0	\$0	\$0	\$0	\$0	\$0	\$729,594	\$1,555,000
													47%	

SALES TAX REVENUE- SC/ED RESTRICTED														
	July	August	September	October	November	December	January	February	March	April	May	June	Totals	Budgeted
GS 105-524	\$33,652	\$33,652	\$33,652	\$33,652	\$33,652	\$33,642							\$201,902	\$400,000
													Total Budgeted	\$400,000

FY 2015-2016

SALES TAX - GENERAL FUND														
	July*	August	September	October	November	December	January	February	March	April	May	June	Totals	Budgeted
Art. 39	\$47,938	\$115,595	\$30,156	\$49,667	\$36,908	\$44,054	\$56,067	\$43,786	\$42,799	\$46,881	\$49,014	\$40,438	\$603,303	\$565,000
Art. 40	\$22,581	\$38,611	\$16,843	\$22,402	\$18,396	\$20,726	\$25,735	\$20,152	\$20,051	\$22,074	\$22,837	\$20,103	\$270,511	\$425,000
Art. 42	\$11,220	\$24,478	\$7,847	\$11,471	\$9,023	\$10,389	\$12,986	\$10,441	\$10,225	\$10,915	\$11,454	\$9,718	\$140,167	\$125,000
Art. 44	\$2	\$20,549	\$2	\$6	\$0	\$0	\$0	\$0	\$0	\$0	-\$0.04	\$0	\$20,559	
Totals	\$81,741	\$199,233	\$54,847	\$83,547	\$64,328	\$75,169	\$94,788	\$74,379	\$73,075	\$79,870	\$83,305	\$70,259	\$1,034,540	
Total Budgeted														\$1,115,000

SALES TAX REVENUE- RESTRICTED SCHOOL CAPITAL RESERVE FUND														
	July*	August	September	October	November	December	January	February	March	April	May	June	Totals	Budgeted
Art. 40	\$17,256	\$16,547	\$15,215	\$15,586	\$14,584	\$15,428	\$18,767	\$13,473	\$14,140	\$17,104	\$16,969	\$16,578	\$191,646	\$160,000
Art. 42	\$34,511	\$36,716	\$30,430	\$31,171	\$29,167	\$30,856	\$37,533	\$26,946	\$28,279	\$34,209	\$33,938	\$33,156	\$386,913	\$190,000
Totals	\$51,767	\$53,264	\$45,645	\$46,757	\$43,751	\$46,284	\$56,300	\$40,419	\$42,419	\$51,313	\$50,907	\$49,733	\$578,559	
Total Budgeted														\$350,000
Grand	\$133,508	\$252,497	\$100,492	\$130,304	\$108,079	\$121,453	\$151,088	\$114,798	\$115,493	\$131,183	\$134,212	\$119,993	\$1,613,099	\$1,465,000

*Amended SC/ED-School Capital/Economic Development

Notes: 8-2015 includes a lump sum payment for an audit creating a higher than usual sales tax payment.

Attachment: Sales tax collections 16-17 (1574 : FY 16-17 Sales Tax Revenue Collections)



Board of Commissioners
AGENDA ITEM SUMMARY SHEET

Information, Reports & Minutes From Other Agencies

Item Number: 11.G
Meeting Date: March 06, 2017

Submitted By: Tony Perry, Sheriff
Sheriff
Prepared by: Angela Wooten

Item Title **Sheriffs Monthly Report - January 2017**

Attachments: Sheriffs Monthly Report - January 2017 (XLSX)

Summary:

Recommendation:

Camden County Sheriff's Office Monthly Stats January-17

Date		Property Crimes	Breaking & Entering	Larceny	Crimes Against Persons	Animal Control Calls	Assaults	Mental Commit.	Drug Arrests
Current:	17-Jan	11	2	10	1	30	2	3	0
Last Month:	16-Dec	12	2	8	6	20	2	4	2
Last Year:	16-Jan	1	1	3	4	28	2	1	1
Traffic Offense	Other Arrest	Juvenile Arrest	Total Arrest	Reports	Papers Served	Armed Robbery	Calls Answered	Building Checks	Avg. Jail Population
116	14	0	130	237	81	0	853	421	0
165	2	0	169	215	48	1	829	370	0
38	7	0	46	188	53	0	1,866	382	0

Calls Answered:	853
Per Day Average	28.0

Calls for Service 2017:	853
Calls for Service 2016:	11,794
Calls for Service 2015:	14,326

Trainings

Radar
Firearm Instructor



Board of Commissioners
AGENDA ITEM SUMMARY SHEET

Information, Reports & Minutes From Other Agencies

Item Number: 11.H
Meeting Date: March 06, 2017

Submitted By: Angela Wooten, Clerk to the Board
Administration
Prepared by: Angela Wooten

Item Title MOA Program Calendar Feb - Apr 2017.Pdf

Attachments: MOA Program Calendar Feb - Apr 2017 (PDF)

Summary:

Recommendation:



MUSEUM OF THE ALBEMARLE

History Happens Here

February - April 2017 Program Calendar



MUSEUM OF THE ALBEMARLE

CELEBRATING 50 YEARS: 1967-2017

February 2017:

School Day: Talking Drums to Emancipation



Friday, February 24th - 9 am – 1 pm

Special school programming will feature Atumpan-The Talking Drums. When and how did the first Africans arrive in the Albemarle? What was their life like? What did emancipation mean? Explore these questions from first arrival until emancipation with hand-on activities and interactive programming.

Call for reservations.

School Day: African Americans in World War I



Friday, February 24th – 9 am – Noon

Schools and organized groups can learn more about the North Carolina men who served in the Great War, such as Moses Sharp from Hertford County. Follow them through turbulent times in foreign lands, and find out what life was like for those who remained at home.

Call for reservations – (252) 335-1453.

Happy Birthday, Dr. Seuss! Celebration Week

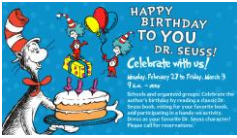

Monday, February 27th – Friday, March 3rd - 9 am – Noon

Schools and organized groups: Celebrate the author’s birthday by reading a classic Dr. Seuss book, voting for your favorite book, and participating in a hands-on activity. Dress as your favorite Dr. Seuss character! Call for reservations – (252) 335-1453.

March 2017:

History for Lunch: Lt. Jennifer L. Charlton



Wednesday, March 1st - 12:15 – 1 pm

Celebrate Women’s History Month with Lt. Jennifer L. Charlton, who will share experiences, such as being one of the first females to complete the US Navy Submarine Officer Basic Course and serving as supply officer on the USS Michigan.

Happy Birthday, Dr. Seuss!



Thursday, March 2nd – 10 – 11 am

Celebrate the author’s birthday by reading a classic Dr. Seuss book and participating in a hands-on activity. Dress as your favorite Dr. Seuss character!

Pinewood Derby



Saturday, March 4th - 9 am – 4 pm

Celebrate Scouting in North Carolina! Watch as boy scouts from the Tidewater Council, Albemarle District race their hand-crafted cars down the track.

Attachment: MOA Program Calendar Feb - Apr 2017 (1593 : MOA Program Calendar Feb - Apr 2017.Pdf)

March 2017 Continued:

Ultimate Wedding Expo



Sunday, April 23rd – 1 – 6 pm

Visit our Best Day Ever - Wedding Expo – Engagement Party Edition! - sponsored by **The Bridal Lounge** boutique. Whether you envision a lavish affair for hundreds or an intimate gathering of family and friends, you'll find the products, services, and items necessary to make your dream wedding truly special.

For more information or to reserve your space, contact The Bridal Lounge at (252) 267-1230

Tot Time: Victory Gardens



Thursday, March 9th – 10 – 11 am

Preschoolers ages 3–5: Learn how children helped to feed people, then hear a story and participate in a hands-on activity.

Student's Day on the River



Friday, March 31st - 9 am – Noon

Students will have the opportunity to explore the maritime heritage, both historical and natural, of the Albemarle Region. Call for reservations.

April 2017:

History for Lunch: “Nell Cropsey and Jim Wilcox: The Chill of Destiny”

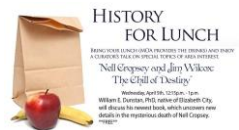

Wednesday, April 5th - 12:15 pm – 1 pm

William E. Dunstan, PhD, native of Elizabeth City, will discuss his newest book, which uncovers new details in the mysterious death of Nell Cropsey.

April 2017 Continued:

Looking for the Tomb of Joseph of Arimathea

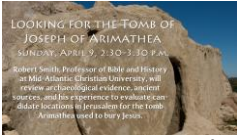

Sunday, April 9th - 2:30 – 3:30 pm

Robert Smith, Professor of Bible and History at Mid-Atlantic Christian University, will review archaeological evidence, ancient sources, and his experience to evaluate candidate locations in Jerusalem for the tomb Arimathea used to bury Jesus.

Tot Time: Discover Tools of an Archaeologist



Discover the Tools of an Archaeologist

Thursday, April 13th, 10am - 11am
Preschoolers ages 3-5: Discover how important archaeological tools are and participate in a hands-on activity.

Thursday, April 13th – 10 – 11 am

Preschoolers ages 3–5: Discover a few important archaeology tools and participate in a hands-on activity.

Museum of the Albemarle's 50th Anniversary Black-Tie Gala



Friday, April 21st – 7 – 11 pm

Join Friends of the Museum of the Albemarle as they host a Gala for the 50th Anniversary of Museum of the Albemarle!

A 50th Anniversary Celebration and Black-Tie Gala! Dancing with music by The Band Punch!. Dinner catered by Kelly's, Open Bar, and Live & Silent Auctions!



MUSEUM OF THE ALBEMARLE

CELEBRATING 50 YEARS: 1967-2017

MOA's Current Exhibitions:

Distant Echoes: Black Farmers in America (through June 2017)

I DO! Weddings in the Albemarle, 1831-2015

Museum of the Albemarle 50th Anniversary (Opening May 8th)

North Carolina Shad Boat

Our Story: Life in the Albemarle

Tar Heels in the Trenches: The Albemarle and the Great War (through December 2018)

Toys from the Past (through February 2017)