



CAMDENCOUNTY
new energy. new vision.

**BOARD
OF
COMMISSIONERS**

September 8th, 2015

**6:00 PM Closed Session
7:00 PM - Regular Meeting**

**Historic Courtroom
Courthouse Complex**

1 **Camden County Board of Commissioners**
2 **Regular Meeting**
3 **May 4th, 2015**
4 **7:00 P.M. - Regular Meeting**
5 **Historic Courtroom, Courthouse Complex**
6 **Camden, North Carolina**
7 **MINUTES**

8
9 The regular meeting of the Camden County Board of Commissioners was held
10 on May 4th, 2015 in the Historic Courtroom, Camden, North Carolina. The
11 following Commissioners were present:

12
13 Chairman Michael McLain, Vice Chair Sandra Duckwall,
14 Commissioners Garry Meiggs, Clayton Riggs and Tom White;

15
16 Also attending were County Finance Officer Stephanie Humphries, County
17 Attorney John Morrison and Clerk to the Board Angela Wooten. Present for
18 purposes of making a presentation(s) or providing supporting information for
19 agenda items were the following persons: Planning Director Dan Porter, Tax
20 Administrator Lisa Anderson.

21
22
23 **Regular Session, 7:00 P.M.**

24
25 Chairman Michael McLain called to order the May 4th, 2015 meeting of the
26 Camden County Board of Commissioners at 7:00 PM.

27
28
29 **Invocation and Pledge of Allegiance**

30
31 Commissioner Sandra Duckwall gave the invocation and led those present in the
32 Pledge of Allegiance.

33
34
35 **Public Comments**

36
37 None

40 **Consideration of Agenda**

41

42 Chairman Michael McLain asked if there were any changes to the agenda. Not
43 hearing any changes, Chairman Michael McLain called for a motion.

44

45 Commissioner Garry Meiggs made a motion to approve the agenda as presented.
46 The motion passed 5-0 with Chairman McLain, Vice Chair Sandra Duckwall,
47 Commissioners Garry Meiggs, Clayton Riggs and Tom White voting aye; no
48 Commissioner voting no; no Commissioner absent; and no Commissioner not
49 voting.

50

51

52 **Presentations**

53

54 ***Item 3.A - Keith Hamm, BA, QP Mobile Crisis Supervisor***

55

56 Keith Hamm, Mobile Crisis Supervisor for the Albemarle Area gave a brief
57 overview of the Mobile Crisis Program and how it has impacted the lives of
58 several Camden Citizen in 2014.

59

60 Integrated Family Services PLLC Mobile Crisis Management is a service available
61 24 hours a day/365 days per year at no cost to the individual receiving the service.
62 Our Mobile Crisis Team is endorsed by East Carolina Behavioral Health (ECBH)
63 to provide this service in Northeastern NC including Camden.

64

65 Mobile crisis responds to individuals in the community in an effort to deescalate
66 their crisis, develop appropriate strategies for symptom reduction, and make
67 linkages to services designed to prevent future crisis situations. This service
68 responds to crisis situations involving mental health, substance abuse, and
69 individuals who are developmentally delayed.

70

71 In 2014, IPS Mobile Crisis responded to 30 individuals in Camden County and
72 83% were diverted from inpatient care and incarceration. Of those individuals, 5
73 requests came from Law Enforcement. Additionally, 7 clients were referred
74 directly from schools in Camden County.

75

76

77

78

79

80 Public Hearings

81

82 *Item 4.A - Ordinance 2015-04-01 Rezoning Application (UDO 2015-03-11)*
83 *Harbinger Land & Timber LLC and Assorted Development Corp – Gary Dunston*

84

85 Commissioner Sandra Duckwall made a motion to go into public hearing for
86 Ordinance No. 2015-04-01 Rezoning Application (UDO 2015-03-11) Harbinger
87 Land & Timber LLC and Assorted Development Corp – Gary Dunston. The
88 motion passed 5-0 with Chairman McLain, Vice Chair Sandra Duckwall,
89 Commissioners Garry Meiggs, Clayton Riggs and Tom White voting aye; no
90 Commissioner voting no; no Commissioner absent; and no Commissioner not
91 voting.

92

93 Planning Director Dan Porter, advised the board Mr. Gary Dunstan owner/part
94 owner of both properties has applied to rezone approximately 41 (farmland) of
95 the 50 plus acres from Basic Residential (R3-2) to Basic Residential (R3-1).
96 Property located at the intersections of Sandy Lane, Keeter Barn and Sharon
97 Church Roads in South Mills Township. Staff presented the rezoning to the
98 Planning Board on April 15, 2015 with the applicant present and after discussion
99 Planning Board made the following motions:

- 100 1. Consistency Statement: Approved a motion that the application for rezoning
101 was consistent with both the CAMA Land Use Plan and Comprehensive Plan
102 as both allowed densities of 1 acre lots.
- 103 2. Motion was made and approved to rezone the 41 acres (farmland) from Basic
104 Residential (R3-2) to Basic Residential (R3-1).

105

106 Chairman Michael McLain asked if there were any comments from members of
107 the public that wish to come forward.

108

109 Larry Hewitt of Sharon Church Road in South Mills states that he and his wife
110 chose their 9 acre lot because it has been a dream of theirs to live in the country.
111 He would not like to rezone the development to 1 acre lots.

112

113 Mark Bissell advises that there are many benefits of having one acre lots allow
114 them to build a higher level of design with all housing frontages on interior
115 streets. He also mentions that there will be no driveways or mail boxes on the
116 state roads. The entire woodland area can be either preserved or turned into a
117 park. He believes the county will like the development. He then asks if there are
118 any questions from the board.

119

120 Vice Chair Sandra Duckwall asked how many houses would be built on the 41
121 acres.

122

123 Mr. Bissell replied it would be in the low 40's.

124

125 Commissioner Tom White requested information with regard to size of the
126 proposed homes when built on 1 acre lots.

127

128 Gary Dunston of Kitty Hawk is one of the developers and advised they are
129 proposing to 2000sq/ft. – 2500sq/ft. homes in the \$300,000 range.

130

131 Chairman Michael McLain asked if there were any further comments from the
132 public regarding this issue. Hearing none, he advised that the board would vote
133 at the next regular meeting due to opposition heard during the public Hearing.

134

135 Commissioner Tom White made a motion to close the public hearing. The
136 motion passed 5-0 with Chairman McLain, Vice Chair Sandra Duckwall,
137 Commissioners Garry Meiggs, Clayton Riggs and Tom White voting aye; no
138 Commissioner voting no; no Commissioner absent; and no Commissioner not
139 voting.

140

141

142 **Board Appointments**

143

144 ***Item 5.A - Economic Improvement Council***

145

146 Chairman McLain informed the board that the Economic Improvement Council
147 is looking for a volunteer to replace Camden's current representative. Clerk to
148 the Board Ms. Wooten confirms that currently the county does not have any
149 volunteer applications on file for the Economic Development Commission and
150 that Commission meets every other month..

151

152 Chairman Michael McLain requests that anyone interested in serving on the
153 Economic Development Commission should completed a Volunteer Application
154 and submit it to the County Managers office. Once there is a willing volunteer on
155 file, he will request this appointment be added to the agenda for the following
156 regular meeting.

157

158

159

CAMDEN COUNTY BOARD OF COMMISSIONERS
 Regular Meeting – May 4th, 2015

160 **Consent Agenda**

161

162 Commissioner Clayton Riggs made a motion to approve the consent agenda as
 163 presented. The motion passed 5-0 with Chairman McLain, Vice Chair Sandra
 164 Duckwall, Commissioners Garry Meiggs, Clayton Riggs and Tom White voting
 165 aye; no Commissioner voting no; no Commissioner absent; and no Commissioner
 166 not voting.

167

168

169 *Item 6.A - Draft Minutes –March 2nd, 2015*

170

171

172 *Item 6.B - Budget Amendments – BA022*

173

Section 1. To amend the General Fund as follows:

ACCT NUMBER	DESCRIPTION OF ACCT	AMOUNT	
		INCREASE	DECREASE
10-380470-434120	Clawback Refund	\$59,994.00	
104700-504300	Clawback	\$59,994.00	

This Budget Amendment is made to payback NC Dept of Commerce for clawback provision in grant.

This will result in a decrease of \$0 in the Contingency of the General Fund.

Balance in Contingency \$25,500.00

174

175

176

177 *Item 6.C - School Budget Amendments*

178

Code Number	Description of Code	Amount	
		Increase	Decrease
5100	Regular Instructional Programs	2,643.83	
5200	Special Instructional Programs		33,558.00
5800	School Based Support Services	39,910.00	
6100	Support & Development Serv.		773.00
6400	Technology Support Services		333.00
6600	Financial & Human Res Serv.	1,120.00	
6900	Policy, Ldrshp, & Pub Relations		8,496.00
7200	Child Nutrition Services	2,130.00	
Explanation: Funds received from USCG Jr. Leadership Program			
Total Appropriation in Current Budget		\$	1,467,278.00
Amount of Increase/Decrease of Above Amendment			2,643.83
Total Appropriation in Current Amended Budget		\$	1,469,921.83

CAMDEN COUNTY BOARD OF COMMISSIONERS
 Regular Meeting – May 4th, 2015

8. Other Local Current Expense Fund

A. We have received our allotment for the 2014-15 USCG Junior Leadership Program and must increase our budget to reflect additional funds received. We request your approval of the following amendment.

<u>USCG Jr. Leadership Program</u>		
5110.301.123	Salary – Instructor	\$ + 2,643.83
Total – USCG Jr. Leadership Program		\$ + 2,643.83 =====
8.3590.301 Revenue – USCG Jr. Leadership Prog.		\$ - 2,643.83 =====

B. We have reviewed this area of the budget and must transfer funds to cover costs of supplies and equipment within the program area. We request your approval of the following amendment.

<u>Carol M. White PEP Grant</u>		
5113.332.411	Supplies & Materials	\$ + 18,000.00
5113.332.541	Purchase of Equipment	- 18,000.00
Total – Carol M White PEP Grant		\$ + 0.00

C. We have reviewed this program area and find that we must transfer funds within the budget to cover contracted services and workshop expenses. We request your approval of the following amendment.

<u>Maintenance of Plant</u>		
6580.802.311...50	Contracted Services	\$ + 7,795.00
6580.802.422...50	Repair Parts, Materials, Labor	- 7,795.00
Total – Maintenance of Plant		\$ + .00

D. We have reviewed this area of the budget and must transfer funds within the budgeted areas to cover contracted services for our students with special needs. We request your approval of the following amendment.

<u>Children with Special Needs</u>		
5210.849.311	Contracted Services	- 33,558.00
5840.849.311	Contracted Services	+ 33,558.00

Other Local Current Expense Fund
 Budget Amendment
 April 16, 2015, Page 2

Total – Children with Special Needs	\$ + .00
-------------------------------------	----------

E. We have reviewed this program area and find that we must transfer funds to cover the cost of contracted services for the policy manual work being done. We request your approval of the following amendment.

<u>Board of Education</u>		
6910.860.192	Salary – BOE Member	\$ - 8,300.00
6910.860.311	Contracted Services	+ 8,300.00
Total – Board of Education		\$ + .00

F. We have reviewed this area of the budget and must transfer funds within the budgeted areas to cover expenses. We request your approval of the following amendment.

<u>School Technology</u>		
5110.905.311	Contracted Services	\$ - 1,557.00
5110.905.418	Comp Software & Supplies	- 1,000.00
5110.905.462	Pur of Non-Cap Comp Hdwe	+ 2,557.00
5860.905.418	Comp Software & Supplies	+ 481.00
5860.905.462	Pur of Non-Cap Comp Hdwe	+ 5,871.00
6110.905.422	Repair Parts & Materials	- 773.00
6400.905.341	Telephone – Telecom	- 418.00
6400.905.462	Pur of Non-Cap Comp Hdwe	+ 85.00
6610.905.462	Pur of Non-Cap Comp Hdwe	+ 1,120.00
6940.905.319	Other Prof & Tech Services	- 2,500.00
6940.905.341	Telephone – Telecom (CO)	- 3,000.00
6940.905.462	Pur of Non-Cap Comp Hdwe	- 2,996.00
7200.905.418	Comp Software & Supplies	+ 310.00
7200.905.462	Pur of Non-Cap Comp Hdwe	+ 1,820.00
Total – School Technology		\$ + .00

179
 180
 181
 182
 183
 184
 185
 186
 187
 188
 189

CAMDEN COUNTY BOARD OF COMMISSIONERS
 Regular Meeting – May 4th, 2015

190 **Item 6.D - Expenditure Request**

191

192 The Camden Volunteer Fire Department is requesting funds for needed
 193 equipment.
 194

DATE: 04/21/15
 INVOICE: 006753
 CUSTOMER PO#: Wagon

SOLE TO: CAMDEN FIRE DEPARTMENT
 ATTENTION: G. A. Cortright/Wagon Wagon
 483 North NC Highway 8343
 Camden, NC 27821

DELIVERED TO: FIRE STATION

Rebate Equipment on the following sheets of information and pricing
 w/ the department's discounts as shown:-----

\$	\$ 24,887.75
Labour/Transit as Shown w/ Discounts	412.20
	87.20
	28.20
Service/Maintenance	900.00
Total	\$ 26,115.35
NC Sales Tax	1,100.89
County Taxes	900.21
Shipping from Manufacturer	66.57
Total Due	\$ 28,683.02

195

196

197

198 **Item 6.E - Tax Refunds, Pickups, & Releases**

199

REFUNDS OVER \$100.00

North Carolina Vehicle Tax System
 NCVTS Pending Refund report

Plate No	Address	Agency	Vehicle ID	PLF	PLF Year	Rate	Vehicle Type	Vehicle Description	Vehicle Status	Plate Type	Registration Exp	Tax Amount	Inty Tax	Charge	Status	Tax Charge
WVCO 70 004 130	CANDLER, NC 27513	Police	0011900	019000	019000	019000	019000	Police	019000	019000	019000	019000	019000	019000	019000	019000
WVCO 70 004 130	CANDLER, NC 27513	Police	0011900	019000	019000	019000	019000	Police	019000	019000	019000	019000	019000	019000	019000	019000
WVCO 70 004 130	CANDLER, NC 27513	Police	0011900	019000	019000	019000	019000	Police	019000	019000	019000	019000	019000	019000	019000	019000
WVCO 70 004 130	CANDLER, NC 27513	Police	0011900	019000	019000	019000	019000	Police	019000	019000	019000	019000	019000	019000	019000	019000

REFUNDS OVER \$100.00

ACE Tax System
 4/22/15 11:28:28

Refunds to be Issued by Finance Office

Refund	Agency	Vehicle ID	PLF	PLF Year	Rate	Vehicle Type	Vehicle Description	Vehicle Status	Plate Type	Registration Exp	Tax Amount	Inty Tax	Charge	Status	Tax Charge
389.28	TRIPLEWOOD BOARD	350 TROTMAN ROAD	CANDLER	NC 27513	2014	03-0354-02-81-9557-0000	20136889 09	218448	Should have been delinquent						
389.28	TRIPLEWOOD BOARD	350 TROTMAN ROAD	CANDLER	NC 27513	2015	03-0354-02-81-9557-0000	20196889 09	218448	Should have been delinquent						
389.28	TRIPLEWOOD BOARD	350 TROTMAN ROAD	CANDLER	NC 27513	2016	03-0354-02-81-9557-0000	20196889 09	218448	Should have been delinquent						
389.28	TRIPLEWOOD BOARD	350 TROTMAN ROAD	CANDLER	NC 27513	2017	03-0354-02-81-9557-0000	20196889 09	218448	Should have been delinquent						
1,597.28	TOTAL Refunds														

200

201

202

203

204

205

CAMDEN COUNTY BOARD OF COMMISSIONERS
Regular Meeting – May 4th, 2015

206 **Item 6.F - Expenditure Request**

207

208 The Camden Volunteer Fire Department is requesting to borrow funds for new
209 Fire Truck. Propose 1% interest to avoid market rates and still provide interest to
210 county for loss of interest on cash from bank and a repayment plan of \$100,000
211 per year over 5 years.

212

INVOICE

	Sutphen Corporation PO Box 158 Arlin, OH 43002 Tel 614.889.1005 800.548.5860 Fax 614.889.0874 www.sutphen.com	PLEASE REMIT TO: Sutphen Corporation PO box 631803 Cincinnati, OH 45263-1803	DATE: 04/28/15	NUMBER: HS-0612-02
---	--	--	--------------------------	------------------------------

SOLD TO: County of Camden 317 N. Highway 343 Camden, NC 27921	ORDER NO: HS 5612	DATE: 10/21/14	CUSTOMER'S PO #: 166-00	SALES REP: JS	PREPARED BY: SI	TERMS: Payable in 30 DAYS
--	--------------------------	-----------------------	--------------------------------	----------------------	------------------------	----------------------------------

ITEM / DESCRIPTION:	AMOUNT:
One Sutphen Custom Tanker	\$ 544,467.89
Less Down Payment Received on 11/10/14	\$ (75,000.00)
TOTAL AMOUNT DUE	\$ 469,467.89

213

214

215

216 **Item 6.G - Volunteer Form - CEDC**

217

Application for Citizen Service - Volunteer Form

If you are a citizen of Camden County and would like to serve on one of the County's boards or commissions, please complete this application and return it to the County Manager's Office, 330 East HWY 158, mail to P.O. Box 180, Camden, North Carolina 27921 or e-mail cmcc@cedc.com

Name Christopher Purcell

Mailing Address 116 Billets Bridge Rd Camden NC 27921

Township you live in: Courthouse

Telephone (home) 757-651-5448 (business) 252-337-4111

Email address: chris.purcell@firehousesubs.com

Are you a registered voter? Yes No

Have you ever been convicted of a felony? Yes No

Please identify any talent, interest, skill, experience or educational preparation which might be helpful to a board or commission:
Business Owner
Chair-Billets RC Area Chamber of Commerce
Chairman EC Chamber Legislative Committee

Board or Commissions upon which you are interested in serving: (List on opposite side)
Camden Economic Development Commission

As a member of a Board or Commission, you will be expected to attend at least 75% of the meetings. Please note the by-laws of some Boards and Commissions limit the number of terms served. This application is a notification of your interest to serve on a Board or Commission to be considered by the Board of Commissioners when a vacancy occurs. Thanks for your interest in Camden County Government.

Signature  Date 04-17-2015

218

CAMDEN COUNTY BOARD OF COMMISSIONERS
Regular Meeting – May 4th, 2015

219 **Item 6.H - Consortium Agreement Resolution**
220

RESOLUTION No. 2015-05-01
APPROVING NORTHEASTERN WORKFORCE DEVELOPMENT CONSORTIUM
AGREEMENT

WHEREAS, the counties of Camden, Cherokee, Clatsack, Dare, Gates, Hyde, Pasquotank, Perquimans, Tyrrell and Washington, being independent and contiguous units of local county government (the "Counties"), wish to agree to establish a workforce development consortium ("Consortium") to act jointly as a Local Workforce Development Area under the Workforce Innovation and Opportunity Act (WIOA), Public Law 113-128 as enacted July 22, 2014; and

WHEREAS, in addition to specific authority to enter into the agreement attached hereto, a "County Appointed Representative" for WIOA purposes upon whose representation the State, the Workforce Development Board, the Albemarle Commission (as the local administrative/fiscal agent) and the other Counties may rely, must be designated and authorized to execute the attached agreement and such other agreements as are necessary for purposes of WIOA and who shall sit on the Consortium Board;

BE IT RESOLVED THAT: Chairman Michael McLain, is hereby designated the "County Appointed Representative" for the foregoing purposes and so such he/she is fully authorized to execute the attached agreement and such other and further agreements on behalf of this County as are necessary for these purposes.

ADOPTED, by the Camden County Board of Commissioners on this 4th day of May, 2015.

221
222
223
224 **Item 6.I - 2015 National Day of Prayer**
225

NATIONAL DAY OF PRAYER
MAY 7th, 2015
A PROCLAMATION BY THE CAMDEN COUNTY BOARD OF COMMISSIONERS

WHEREAS, because of the faith of our many founding fathers, public prayer and national days of prayer have a longspanning and significant history in American tradition; and

WHEREAS, since the first call to prayer in 1773, when the Continental Congress asked colonies to pray for wisdom in forming a nation, the call to prayer has continued through our history; and

WHEREAS, in 1986 legislation adopting the first Thursday in May of each year as National Day of Prayer was passed unanimously by both Houses of Congress and signed by President Ronald Reagan; and

WHEREAS, the National Day of Prayer belongs to all Americans and it is a day that transcends differences, bringing together citizens from all backgrounds and all faiths to join in united prayer to acknowledge our dependence on God, to give thanks for blessings received, to request healing for wounds endured, and to ask God to guide our leaders and bring wisdom to the United States and her citizens; and

WHEREAS, the 64th Annual National Day of Prayer will take place on Thursday, May 7, 2015 where millions will unite in prayer at thousands of events from coast to coast; and

WHEREAS, the theme for 2015 is LORD, HEAR OUR CRY, emphasizing the need for individuals, corporately and individually, to place their faith in the unfailing character of their Creator, who is sovereign over all governments, authorities and men, and was inspired by 1 Kings 8:26: "Hear the cry and the prayer that your servant is praying to your presence daily"; and

WHEREAS, it is fitting and proper to give thanks to God by observing a day of prayer in Transylvania County when all may acknowledge our blessings and express gratitude for them, while recognizing the need for strengthening religious and moral values in our State and Nation.

NOW, THEREFORE, The Camden County Board of Commissioners does hereby proclaim May 7th, 2015 to be designated as "A DAY OF PRAYER IN CAMDEN COUNTY" and encourages the citizens of Camden County to observe ways appropriate to its importance and significance.

Adopted this the 4th day of May, 2015.

ATTEST:

Angela Wooten - Clerk to the Board

E. Michael McLain - Chairman

P. O. Box 1303 • 130 East Hwy. 158 • Camden, NC 27513 • Phone: (252) 338-6163 • Fax: (252) 333-7811
www.camdencountync.gov

226
227
228
229
230
231

CAMDEN COUNTY BOARD OF COMMISSIONERS
Regular Meeting – May 4th, 2015

232 **Item 6J - Older Americans Month 2015**
233

OLDER AMERICANS MONTH 2015

A PROCLAMATION BY THE CAMDEN COUNTY BOARD OF COMMISSIONERS

Whereas, Camden County, NC includes a thriving community of older Americans who deserve recognition for their contributions and sacrifices to ensure a better life for future generations; and

Whereas, The Camden County Board of Commissioners is committed to helping all individuals live longer, healthier lives at the communities of their choice for as long as possible; and

Whereas, since 1963, the Older Americans Act has provided services that help older adults remain healthy and independent by complementing existing medical and health care systems, helping prevent hospital readmissions, and supporting some of life's most basic functions, such as bathing or preparing meals; and

Whereas, these programs also support family caregivers, address issues of exploitation, neglect and abuse of older adults, and adapt services to the needs of Native American elders; and

Whereas, we recognize the value of community engagement and service in helping older adults remain healthy and active while giving back to others; and

Whereas, our community can provide opportunities to enrich the lives of individuals of all ages by:

- Promoting and engaging in activity, wellness, and social inclusion.
- Emphasizing home- and community-based services that support independent living.
- Ensuring community members of all ages benefit from the contributions and experience of older adults.

Now therefore, The Camden County Board of Commissioners does hereby proclaim May 2015 to be Older Americans Month and urge every resident to take time this month to celebrate older adults and the people who serve and support them as powerful and vital individuals who greatly contribute to the community.

Adopted this the 4th day of May, 2015.

ATTEST:

Angela Wooten - Clerk to the Board



P. Michael McLain - Chairman

234
235
236 **New Business**

237
238 **Item 7.A - Monthly Tax Report**

239
240 Tax Administrator Lisa Anderson presented the Monthly Tax Report for March
241 2015.
242

**MONTHLY REPORT OF THE TAX ADMINISTRATOR TO THE
CAMDEN COUNTY BOARD OF COMMISSIONERS**

OUTSTANDING TAX DELINQUENCIES BY YEAR

YEAR	REAL PROPERTY	PERSONAL PROPERTY
2014	355,846.64	12,284.33
2013	104,042.04	10,995.48
2012	37,785.87	13,428.28
2011	20,848.32	10,871.28
2010	20,741.09	6,430.54
2009	7,442.87	6,069.27
2008	6,133.35	6,354.62
2007	6,133.10	9,822.26
2006	2,119.08	14,493.82
2005	1,690.71	26,536.96

CAMDEN COUNTY BOARD OF COMMISSIONERS
Regular Meeting – May 4th, 2015

TOTAL REAL PROPERTY TAX UNCOLLECTED	\$42,781.02
TOTAL PERSONAL PROPERTY UNCOLLECTED	117,286.84
TEN YEAR PERCENTAGE COLLECTION RATE	99.00%
COLLECTION FOR 2015 vs. 2014	75,523.93 vs. 94,189.66

LAST 3 YEARS PERCENTAGE COLLECTION RATE

2014	94.58%
2013	98.36%
2012	99.28%

THIRTY LARGEST UNPAID ACCOUNTS

SEE ATTACHMENT "A"

THIRTY OLDEST UNPAID ACCOUNTS

SEE ATTACHMENT "B"

EFFORTS AT COLLECTION IN THE LAST 30 DAYS

ENDING March 2015

BY TAX ADMINISTRATOR

<u>678</u>	NUMBER DELINQUENCY NOTICES SENT
<u>22</u>	FOLLOWUP REQUESTS FOR PAYMENT SENT
<u>2</u>	NUMBER OF WAGE GARNISHMENTS ISSUED
<u>13</u>	NUMBER OF BANK GARNISHMENTS ISSUED
<u>18</u>	NUMBER OF PERSONAL PHONE CALLS MADE BY TAX ADMINISTRATOR TO DELINQUENT TAXPAYER
<u>0</u>	NUMBER OF PERSONAL VISITS CONDUCTED (COUNTY OFFICES)
<u>14</u>	PAYMENT AGREEMENTS PREPARED UNDER AUTHORITY OF TAX ADMINISTRATOR
<u>0</u>	NUMBER OF PAYMENT AGREEMENTS RECOMMENDED TO COUNTY ATTORNEY
<u>0</u>	NUMBER OF CASES TURNED OVER TO COUNTY ATTORNEY FOR COLLECTION (I.D. AND STATUS)
<u>0</u>	REQUEST FOR EXECUTION FILES WITH CLERK OF COURTS
<u>0</u>	NUMBER OF JUDGMENTS FILED

243

244 The County Attorney John Morrison advised the board that Potomac Timber
245 Investments paid their taxes of \$13,979.14 in full.

246

247 Commissioner Tom White made a motion to approve the monthly tax report as
248 presented. The motion passed 5-0 with Chairman McLain, Vice Chair Sandra
249 Duckwall, Commissioners Garry Meiggs, Clayton Riggs and Tom White voting
250 aye; no Commissioner voting no; no Commissioner absent; and no Commissioner
251 not voting.

252

253

254 ***Item 7.B - Engineering Aspects of A Waste Water Treatment Plant***

255

256 Commissioner Clayton Riggs advised that the Engineer, Mr. Robey, was unable to
257 attend tonight's meeting therefore he makes a motion to recess this
258 Commissioners meeting until 3:00 Thursday in the conference room of Hyman
259 and Robey located at the intersection of Gumberry Road and US 158.

260

261 Chairman McLain adds this meeting will be open to the public.

262

263 Commissioners Riggs's motion to recess passed 5-0 with Chairman McLain, Vice
264 Chair Sandra Duckwall, Commissioners Garry Meiggs, Clayton Riggs and Tom
265 White voting aye; no Commissioner voting no; no Commissioner absent; and no
266 Commissioner not voting.

267

268

269 **Commissioner's Report**

270

271 Vice Chair Sandra Duckwall gave the Monthly Library Report.

272

273 Commissioner Tom White provided some highlights from the very successful
274 "Paddle for the Border" in which there were 311 participants and many state
275 dignitaries.

276

277 Commissioner Clayton Riggs attended a K-12 Funding Class at the School of
278 Government and wanted to let everyone know school funding reports are now on
279 line for the public to view.

280

281

282

283 Chairman Michael McLain had the following items to report:

284

- 285 • There is a Ribbon Cutting Ceremony for the Dollar General's Grand Opening on
- 286 Saturday May 9th, 2015 at 7:30 AM and invites the public to come.
- 287 • There is an ECBH Grant for handicap accessible playground equipment and
- 288 hopes the county will apply.

289

290

291 **Information from Board and Staff**

292

293 The following items were provided to the Board for their information, and a copy
294 of these items is maintained in the Clerk's office.

295

- 296 A. Elizabeth City Area Chamber Of Commerce
- 297 B. Economic Value of the College of the Albemarle
- 298 C. Library Report - April
- 299 D. Scotland County Resolution
- 300 E. County News April 20 2015
- 301 F. N.C. Rural Infrastructure Authority Approves Grants
- 302 G. NCACC Legislative Bulletin – April 17, 2015
- 303 H. NCACC Legislative Bulletin - April 24, 2015
- 304 I. House Bill 726
- 305 J. Stepping Up
- 306 K. Will ACOS Raise Medical Prices?
- 307 L. Sales Tax & Revenue Collection Report
- 308 M. Excise Tax Publication
- 309 N. Register of Deeds - April
- 310 O. National Flood Insurance Program Community Assistance Visit
- 311 P. ECBH
- 312 Q. LME County General Funds Report
- 313 R. LGFCU Gives Back

314

315

316

317

318

CAMDEN COUNTY BOARD OF COMMISSIONERS
Regular Meeting – May 4th, 2015

319 **Closed Session**

320

321 Chairman Michael McLain states the need to enter closed session pursuant to
322 NCGS 143.318.11(a)(3) and 143.318.11(a)(5) potential litigation and contract
323 negotiations.

324

325 Commissioner Garry Meiggs made a motion to enter closed session at 7:58 PM.
326 The motion passed 5-0 with Chairman McLain, Vice Chair Sandra Duckwall,
327 Commissioners Garry Meiggs, Clayton Riggs and Tom White voting aye; no
328 Commissioner voting no; no Commissioner absent; and no Commissioner not
329 voting

330

331 Commissioner Garry Meiggs made a motion to come out of closed session at 8:10
332 PM. The motion passed 5-0 with Chairman McLain, Vice Chair Sandra Duckwall,
333 Commissioners Garry Meiggs, Clayton Riggs and Tom White voting aye; no
334 Commissioner voting no; no Commissioner absent; and no Commissioner not
335 voting

336

337

338 **Meeting Recessed**

339

340 At 8:12 PM, Chairman Michael McLain asked if there were any other matters to
341 come before the Board of Commissioners, hearing none, and by acclamation the
342 meeting was recessed until 3:00 PM Thursday in the conference room of Hyman
343 and Robey located at the intersection of Gumberry Road and US 158.

344

345

346

347

348

Chairman Michael McLain
Camden County Board of Commissioners

349

350

351 ATTEST:

352

353

354

355 Angela L. Wooten

356 Clerk to the Board

This agenda is only a tentative schedule of matters the Commissioners may address at their meeting and all items found on it may be deleted, amended or deferred. The Commissioners may also, in their absolute discretion, consider matters not shown on this agenda.

Please turn Cell Phone ringers off during the meeting.

Agenda

**Camden County Board of Commissioners Regular Meeting
September 8th, 2015
6:00 P.M. - Closed Session
7:00 P.M. - Regular Meeting
Historic Courtroom, Courthouse Complex
Camden, North Carolina**

6:00 P.M. **Call to Order** - Chairman P. Michael McLain

Closed Session - Pursuant to G.S. 143-318.11(a)(3) - Consultation with Attorney to discuss potential litigation.

7:00 P.M. **Welcome**

Invocation & Pledge of Allegiance – Vice Chairwoman Sandra Duckwall

ITEM 1. **Public Comments**

It is requested that comments be limited to (2-3) minutes. The length and number of comments may be limited upon the Chairman’s discretion due to scheduling and other issues.

ITEM 2. **Consideration of Agenda (For discussion and possible action)**

ITEM 3 **Presentations**

A. Camden Youth Football (Pg. 5-31)

ITEM 4. **Public Hearings**

A. Public Meeting; Sketch Plan Mill Run - Common Open Space Major Subdivision (UDO 2015-06-07) (Pg. 32-66)

ITEM 5. **New Business (For discussion and possible action)**

A. Monthly Tax Report..... (Pg. 67-74)

B. Core Area Waste Water Treatment Plant Proposal for Hydrogeologic and Soils Analysis (Pg. 75-80)

C. Darkness to Light: Child Sexual Abuse Awareness and Prevention Training Program..... (Pg. 81-85)

ITEM 6. Board Appointments (For discussion and possible action)

- A. Jury Commission (Pg. 86-87)

ITEM 7. Consent Agenda (All items listed below are routine and will be approved by one motion. Separate discussion of an item(s) will be held by request of a member of the Board.)

- A. Draft Minutes)
 - May 4th, 2015 Regular Session (Attachment A)
 - June 1st, 2015 Regular Session..... (Attachment B)
 - June 15th, 2015 Regular Session (Attachment C)
 - May 19th & 21st, 2015 Budget Work Sessions..... (Attachment D)
 - June 8th 2015 Budget Hearing..... (Attachment E)
- B. Budget Amendments – BA002 through BA005 (Pg. 89-93)
- C. Expenditure Request (Pg. 94-98)
- D. Tax Collection Report (Pg. 99-100)
- E. Tax Refunds, Pickups, & Releases (Pg. 101-105)
- F. Tax Authorization to Collect (October Renewals) (Pg. 106-107)
- G. Constitution Week Proclamation (Pg. 108-110)
- H. Set Public Hearing: Ordinance No. 2015-08-01 –
Proposed Amendments to Chapter 151 (Unified Development
Ordinance) of the Camden County Code Ordinances..... (Pg. 111-120)
- I. Shiloh Baptist Church Resolution (Pg. 121-128)

ITEM 8. Commissioner's Report (For discussion and possible action)

ITEM 9. County Manager's Report (For discussion and possible action)

- A. Board Vacancies –
 - Parks and Recreation
 - Adult Care Home Community Advisory Committee (CAC)
- B. All BOC Meetings are posted on the county website

Recess Commissioner's Meeting

SOUTH CAMDEN WATER & SEWER DISTRICT
BOARD OF DIRECTORS

- 1. **Call to Order**
- 2. **Public Comments**
- 3. **Consideration of Agenda**
- 6. **New Business** (For Discussion and Possible Approval).
 - A. Monthly Update to the Board (Pg. 129-130)
 - B. Construction of Seymour Drive Well Site and Raw Water Main (Pg. 131-144)
- 7. **Other Matters** (For Discussion and possible action.)
- 8. **Adjourn**

Reconvene Commissioner’s Meeting

ITEM 10. Information, Reports & Minutes From Other Agencies (Pg. 145-157)

- A. Sales Tax Report (Pg. 146)
- B. Register of Deeds Monthly Report - July (Pg. 147-148)
- C. Register of Deeds Monthly Report - August (Pg. 149)
- D. EMS Monthly Report - July (Pg. 150)
- E. Library Monthly Report - August (Pg. 151-152)
- F. New Deputy Commissioners Appointed (Pg. 153-154)
- G. Mobile App for Job Seekers (Pg. 155)
- H. NCWorks Career Centers Give Free Food to Veterans (Pg. 156-157)

ITEM 11. Other Matters (For discussion and possible action)

ITEM 12. Adjourn

**Camden County Board of Commissioners
AGENDA ITEM SUMMARY SHEET**

Item Number: 3.A

PRESENTATIONS

Meeting Date: September 8th, 2015
Attachments: 1 (26 Pages)
Submitted By: Camden Youth Football
ITEM TITLE: Camden Youth Football

MOTION MADE BY:	
S. Duckwall	
G. Meiggs	
M. McLain	
C. Riggs	
T. White	
NO MOTION	
VOTE:	
S. Duckwall	
G. Meiggs	
M. McLain	
C. Riggs	
T. White	
ABSENT	
RECUSED	

SUMMARY:

Camden Youth Football presented by Karyn Smith

RECOMMENDATION:

Information only

Camden Bears Youth Football & Cheerleading



Objectives

- Background
- Updates
- Requests

History

- Camden Youth Football and Cheerleading (CYFC) organization was established in 2002 as the first youth football program in Camden County
- Member of the Albemarle Youth Football League
Dare, Currituck, Camden, Pasquotank, Perquimans, Chowan, Gates, and Hertford counties
- Strengthened Camden Middle School and High School sports programs
- Practiced and held home games at the Camden Community Park

Background

After 13 years of dedication to Camden Youth Football and Cheerleading (CYFC), the original founders asked Camden Parks and Recreation to take over administrative responsibilities while they continued to volunteer their time to the organization. This request was made on 5/27/15 via a letter to Parks and Recreation.

Camden Youth Football & Cheerleading

Camden, NC

05/27/2015

To Tim White,

Tim due to my very busy work schedule again this year and some other changes in our lives I feel the time has come to turn the Camden Youth Football & Cheerleading operation over to Camden County Parks and Recreation Department immediately. We just do not have the time at this point to give the full commitment needed to keep this an excellent organization for the youth in Camden County. As you know the majority of the teams in the Albemarle Youth Football League, which we are a member, are run by their respective Parks and Recreation Departments. Also you are aware we started this organization in the year 2002 as the first youth football organization in Camden County with the hope of one day having our own Parks and Recreation Department who could take over at some point and time. I know with the budget already submitted this year we are willing to help purchase some equipment which may be needed. But I do not anticipate that being a lot this year as we purchased some new equipment last year. Also we are still willing to help on Saturdays when you would host games which are typically 3 to 4 times a season and we are willing to help if needed for other things during the course of the season when available. I hope we can make this a quick and easy transition as we normally hold sign-ups the last week in June. This would give you and the Department time to advertise several weeks. Again thanks and we look forward to hearing from you. Please call with any questions.

Thanks again,

Ricky & Cindy McPherson

Darren & Melissa Cochran

Misunderstanding

On 6/5/15 the County Manager replied with a letter to the organization stating :

“It was with great regret that I read of your organization’s intentions to no longer offer a youth football and cheerleading program in Camden County.”

This was not stated in the 5/27/15 letter.

P. MICHAEL McLAIN
Chairman

SANDRA J. DUCKWALL
Vice Chairman

GARRY W. MEIGGS
CLAYTON D. RIGGS
TOM WHITE



MICHAEL RENSRAW
County Manager

ANGELA WOOTEN
Clerk to the Board

JOHN S. MORRISON
County Attorney

Camden Youth Football & Cheerleading

June 5, 2015

C/O: Mr. and Mrs. McPherson
Mr. and Mrs. Cochran

Delivery: Via Email

My office is in receipt of the email and letter from Camden Youth Football & Cheerleading dated May 27, 2015 (copy attached). It was with great regret that I read of your organization's intentions to no longer offer a youth football and cheerleading program in Camden County.

Your organization's request for the Camden County Parks & Recreation Department to assume responsibility for operating this program was discussed with the Board of Commissioners during its regular meeting on June 1st. The matter was again discussed during the June 4th Parks & Recreation Advisory Board meeting. The purpose of this letter is to advise your organization that at this time Camden County does not intend to assume the operations of the former Camden Youth Football & Cheerleading operations.

On behalf of the Camden County Board of Commissioners, I wish to thank you and the members of Camden Youth Football & Cheerleading for their dedication and commitment to providing organized youth sport opportunities for the children of Camden County and wish you well in your future endeavors.

Very sincerely,

Michael Renshaw

Camden County Manager

Cc: Camden Board of Commissioners
Tim White, Camden County Parks & Recreation Director

Response from Camden Youth Football and Cheerleading

Summary of email reply on 6/08/2015 from CYFC to County Manager:

- In the letter dated 5/27/15 from CYFC to Camden Parks and Recreation, their intent was to continue the program and hand off administrative duties to the county.
- Since the County declined to take over the administrative duties, then they planned to continue the program by looking into other options.
- They would contact Parks and Recreation in the next several weeks to keep them informed of their plans.
- It was **NOT** the intent of Camden Youth Football and Cheerleading to end the program.

Email from Camden Youth Football and Cheerleading

From: Ricky Mcpherson (VirginiaPower - 6) <ricky.mcpherson@dom.com>
Sent: Monday, June 08, 2015 11:19 AM
To: 'Mike Renshaw'; 'twhite@camdencountync.gov'
Cc: 'darmel411@centurylink.net'
Subject: RE: Camden Youth Football

After discussing your response with Darren and Melissa Cochran we regret Camden County's decision on this matter, so we are looking at some other options to help continue the Camden Youth Football & Cheerleading organization. Our intent on this matter was to continue to volunteer our time when needed, but to turn over all the administrative work. We have a great program and have a great relationship with the other surrounding counties and do not want this program to end. I will be in contact with Tim White over the next several weeks to keep him informed on this matter and a solution.

Thanks,
Ricky McPherson

June 8, 2015 – June 12, 2015

Gearing Up for the CYFC Sign Ups

- All Grandy Primary School students receive flyer from Camden Youth Football and Cheerleading regarding signups on June 22, 2015.
- All Camden Intermediate School students receive flyer from Camden Youth Football and Cheerleading regarding signups on June 22, 2015.

Seven Days Later....

Monday, June 15, 2015 Commissioners Meeting

- County Manager requested a motion be made to operate youth soccer in place of the “dissolved” Camden Youth Football and Cheerleading program.
- It was stated that there would be an agreement between the Shiloh Sharks and Soccer Program to share the fields at Camden Community Park.

Another Seven Days Later...

June 22, 2015

- Signups begin at 6pm
- Daily Advance article is published stating:
 - “Camden Commissioners agreed last week to allow the Camden Youth League to use practice fields for soccer games and practices after one of two football leagues appeared to end its program”
 - “McPherson told County Manager Mike Renshaw in a June 8 email that he would continue to examine options for keeping the Bears program operating.”

New Leaders for the Bears

- Mrs. Karyn Smith and Mr. Randy Smith agreed to run the Camden Youth Football and Cheerleading Organization
- Conducted first meeting with concerned parents and coaches regarding the future of the youth football program
- Obtained information from prior leadership regarding administrative requirements



Tasks Completed

- Met with County Government officials to develop a plan for reinstatement
- Established a Board of Directors
- Met with Attorney to establish Articles of Incorporation for Camden Bears Youth Football
- Purchased liability insurance
- Secured temporary alternative practice fields from Randy and Bob Kraniak
- Completed application for 501c3 paperwork for non-profit status



Starting the Season

- Started first practice on August 10, 2015
- Established three football teams (7-8), (9-10), (11-12 year olds)
- Established three cheerleading teams
- Total enrollment is 85 football players and 30 cheerleaders
- Majority of participants are Camden County residents



Camden Bears Open House

August 25, 2015

Participants Include:

- Commissioners
- Itza Boutza Pizza
- Camden County Public Library
- Randy and Bob Kraniak
- Parents
- Players
- Cheerleaders
- Community



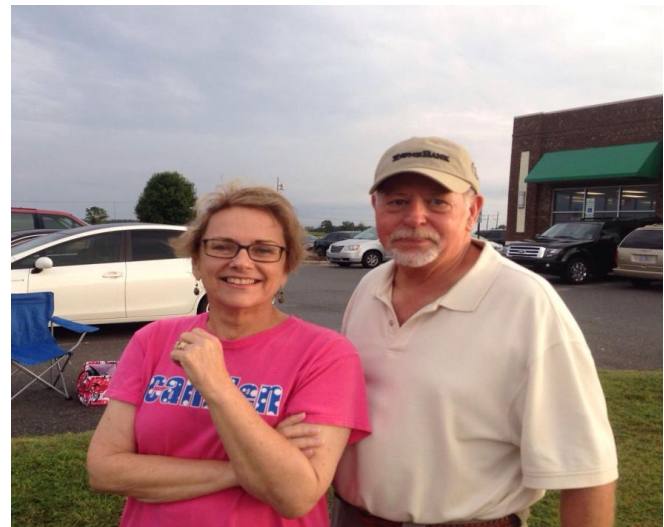

Progress

- Received permission to have two home games during our regular season from Camden County Parks and Recreation
- Received permission to have a lighted field, using the high school soccer field after 6:30pm when no home soccer games are scheduled.

Immediate Requests

- Reconsider our Category II status with the county, due to the misunderstanding regarding the continuation of the youth football program.
- Accept documentation of all required paperwork to reinstate our Category II status. Accept our application for the 501c3 as sufficient documentation for the county requirements.
- Provide lighted field space for three practices per week and Saturday home games for all youth football and cheerleading participants.

Ongoing Requests

- County Government to understand that youth football and cheerleading is important to Camden County Residents.
- County Government to support all youth sports, regardless of the type of sport, by providing field space fairly and adequately for all youth organizations.
- County Government to plan for an increase in youth sports due to fall youth soccer, potential fall youth baseball, and youth football and cheerleading.
- County Government to consider building a sports complex because it is critical to the growth to our community and well being of our children.

Thank You

- Coming out to the Camden Bear Youth Football and Cheerleading Open House
- Working with the organization as it continues to grow
- Providing us the opportunity to address you today and for considering our requests.



**Camden County Board of Commissioners
AGENDA ITEM SUMMARY SHEET**

MOTION MADE BY:	
M. McLain	_____
S. Duckwall	_____
G. Meiggs	_____
T. White	_____
C. Riggs	_____
NO MOTION	_____
VOTE:	
M. McLain	_____
S. Duckwall	_____
G. Meiggs	_____
T. White	_____
C. Riggs	_____
ABSENT	_____
RECUSED	_____

Item Number: 4.A

Meeting Date: September 8, 2015
Attachments: Sketch Plan/Staff Findings/TRC inputs
Submitted By: Planning Department

ITEM TITLE: Public Meeting; Sketch Plan
 Mill Run - Common Open Space Major
 Subdivision (UDO 2015-06-07)

SUMMARY:

Harbinger Land & Timber LLC/Assorted Development Corporation has applied for Sketch Plan approval for Mill Run Subdivision (45 lots) as a Common Open Space (Article 151.290 of the Camden County Code of Ordinances) Major Subdivision. Application went to the Planning Board on July 15, 2015 and after presentation by Planning Staff and discussion made a recommendation to approve the yield plan/sketch plan with the recommendations listed in Planning Staffs Findings.

Rezoning from Basic Residential (R3-2) to Basic Residential (R3-1) approved by Board of Commissioners on June 1, 2015 (Ordinance No. 2015-04-01).

RECOMMENDATION:

Consideration of yield/sketch plan for Mill Run Major Subdivision.

STAFF REPORT

UDO 2015-06-07
Sketch Plan Mill Run Common Open
Space Major Subdivision

PROJECT INFORMATION

File Reference: UDO 2015-06-07 Project Name; N/A PIN: 01-7090-00-07-6888 01-7090-00-17-0117 Applicant: Harbinger Land & Timber, LLC & Assorted Development Corp – Gary Dunston Address: P.O. Box 4 Harbinger NC 27941 Phone: (252) 202-1100 Email: Agent for Applicant: Bissell Professional Group Mark Bissell Address: 3512 N. Croatan Hwy Phone: (252) 261-1760 Email: Current Owner of Record: Same as applicant Meeting Dates: 7/15/2015 Planning Board – Recommended Approval on a 7-0 vote with recommendations from staff	Application Received: 6/8/15 By: David Parks, Permit Officer Application Fee paid: \$6,750 Check #2040 Completeness of Application: Application is generally complete Documents received upon filing of application or otherwise included: A. Land Use Application B. Sketch Plan C. Development Impact Statement D. Perc Tests (4) from Albemarle Regional Health Services
---	--

PROJECT LOCATION:

Street Address: Property fronted by Sandy Lane, Keeter Barn and Sharon Church Roads
Location Description: South Mills Township

Vicinity Map:





REQUEST: Sketch Plan Mill Run Common Open Space Major Subdivision – 45 lots (smallest proposed lot size 22,880 sf or approximately .5 acres) **Article 151.290 of the Code of Ordinances.**

AREA CALCULATIONS:

Net Development Area: 51.28 ac.
 5% Open Space: 2.56 ac.
 Open Space provided: 3.04 ac
 Area in streets: 1.67 ac
 Area available for lots: 46.57 ac.

PRELIMINARY YIELD PLAN

1 Acre lots in R3-1: 37 lots
 2 Acre lots in R3-2: 5 lots
 5% C.O.S. bonus: 2 lots
 Optional Endowment Fund Bonus: 2 lots
 Yield including Bonuses: 46 lots



PROPOSED COMMON OPEN SPACE PLAN

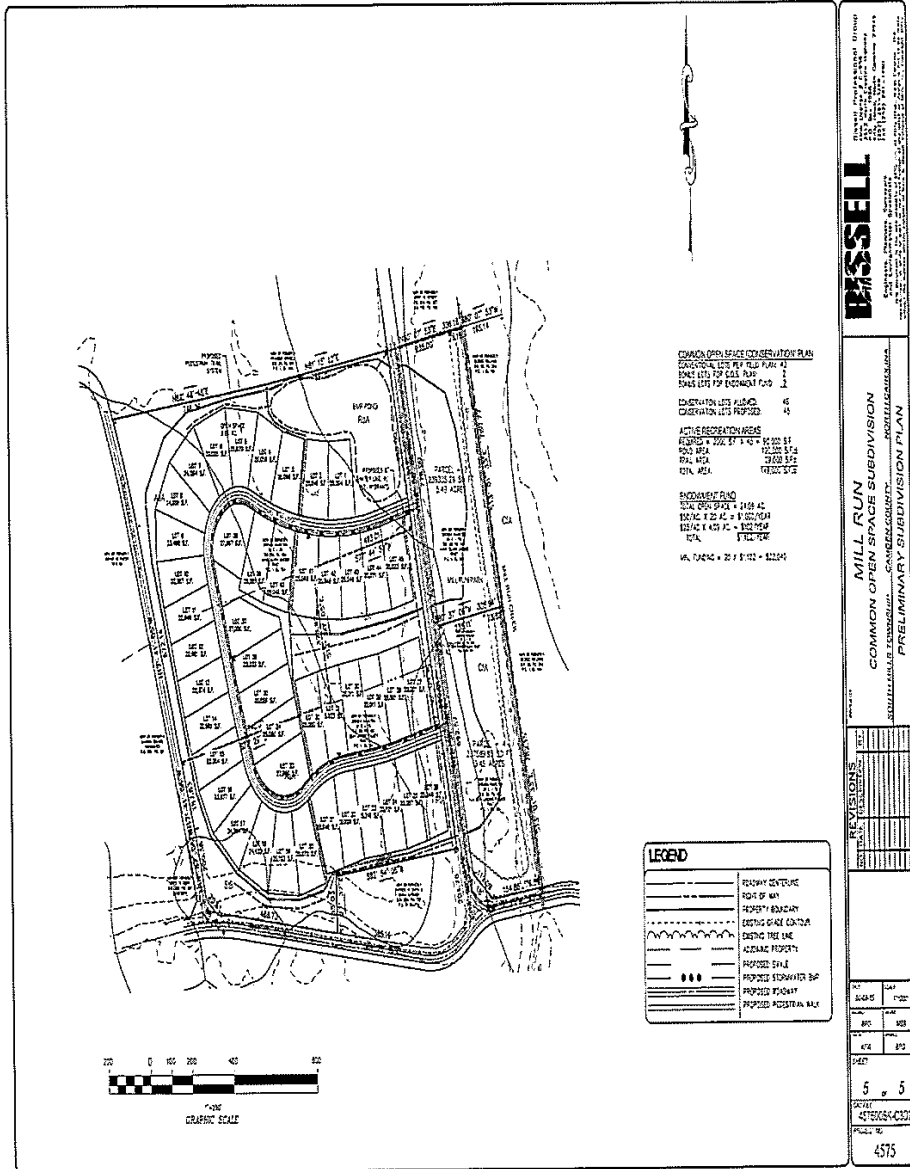

SITE DATA

Lot size:	Two lots approximately 54 acres total.
Flood Zone:	Zone X (Located outside the 100 & 500 year flood)
Zoning District(s):	Basic Residential (R3-1 & R3-2 (wooded areas))
Adjacent property uses:	Predominantly agriculture with some residential.
Streets:	Shall be dedicated to public under control of NCDOT.
Street name:	Mill Run Loop
Open Space:	23.69 acres
Landscaping:	Landscaping Plan required at Preliminary plat.
Buffering:	Per Article 151.232 (N), a 50' landscaped vegetative buffer required along all property lines that abut non-residential uses.
Recreational Land:	Per Article 151.294 (B)(4) A minimum of 2,000 square feet of open space per dwelling must be designated and improved for active recreation. 45 lots X 2,000 = 95,000 sf or 2.1 acres. Per Article 151.232 (I) (3) Recreational Land: The developer shall at the County's option make a payment to the county of the amount of money equal to the value of the 2.1 acres as it would be appraised following its subdivision.

ENVIRONMENTAL ASSESSMENT

Streams, Creeks, Major Ditches: Mill Run Ditch.

Distance & description of nearest outfall: Mill Run Ditch is located to the east of the wooded portion of the property and will probably be utilized as the outfall.

TECHNICAL REVIEW STAFF (SKETCH PLAN) COMMENTS

1. **South Mills Water.** Has adequate water to supply development.
 2. **Albemarle Regional Health Department.** Perc test completed on 4 lots (10% of lots required to be perc tested). Detailed Site Plans required at building permit due to the size of lots.
 3. **South Mills Fire Department.** No response.
 4. **Pasquotank EMS (Central Communications).** Approved subdivision and road name.
 5. **Sheriff's Office.** Approved
 6. **South Mills Post Office** – Community Mail boxes required at entrance.
 7. **Superintendent/Transportation Director of Schools.** Covered bus shelters required.
 8. **Camden Soil & Water Conservationist.** Approved
 9. **NCDOT.** Reviewed no comments at this time.
 10. **Parks & Recreation.** Request fee in lieu of required recreational land/improvements.
-

PLANS CONSISTENCY

CAMA Land Use Plan Policies & Objectives:

Consistent Inconsistent

2035 Comprehensive Plan

Consistent Inconsistent

Property zoned R3-1 (farmland) is consistent as area is designated as Rural Residential.

PLANS CONSISTENCY – cont.

Comprehensive Transportation Plan

Consistent Inconsistent

Property abuts Sandy Lane (SR 1227) (unpaved), Keeter Barn (SR 1226) and Sharon Church (SR 1231) Roads

FINDINGS REGARDING ADDITIONAL REQUIREMENTS:

Yes No

Endangering the public health and safety?

Application does not appear to endanger public health and safety.

Yes No

Injure the value of adjoining or abutting property.

Application does not appear to injure the value of adjoining or abutting property.

EXCEED PUBLIC FACILITIES:

Yes No

Schools: Proposed development will generate 20 students (.44 per household X 45 households). High School over capacity: **2014/2015 capacity: 570 Enrollment: 628**

Yes No

Fire and rescue: No response

Yes No

Law Enforcement:

PLANNING BOARD RECOMMENDATION:

Planning Board recommended approval of Sketch Plan Mill Run Major Subdivision with the following recommendations:

- Reflect the 55' Army Corp drainage easement along western side of Mill Run Ditch.
- Per Parks & Recreation recommend BOC require the fee in lieu of the recreational requirements (Camden County Code Article 151.232 (I) addresses options).
- Recommend the increase the Site Triangle at intersection of Lilly and Sharon Church Roads.
- Adhere to all technical review staff comments.



Land Use/Development Application
County of Camden, North Carolina

Depending upon the type of proposal, the proposal may require a Zoning Permit, Conditional Use Permit, or Special Use Permit. This form is used as the start of application process. All applicants must submit a site plan (see "Minimum Site Plan Requirements") and a valid Health Department permit. Applicants for a Conditional Use Permit or Special Use Permit should review the "Requirements for Conditional Use Permit and Special Use Permit Applications".

Applicants for a subdivision must submit this form as their Special Use Permit application.

Please consult the Planning Office (1-252-338-1919) with any questions about your application.

Please Do Not Write in this Box	
PIN: 01-7090-00-07-6888	01-7090-00-17-0117
UDO#	2015-06-07
Date Received:	6/18/15
Received by:	DP
Zoning District:	R3-1/R3-2
Fee Paid \$	\$ 6,750.00

PLEASE PRINT OR TYPE

pd
CK #
2040

Applicant's Name: Harbinger Land & Timber, LLC & Assorted Development Corporation

If the Applicant is acting as agent for another person (the "principal"), please give that person's name on the line below and submit a copy of the agency agreement/letter with this Application.

Gary Dunston / MARK BISSÉLL

Applicant's Mailing Address: P.O. Box 4
Harbinger, NC 27941

Daytime Phone Number: (252) 202-1100

Street Address Location of Property: Off Sharon Church, Keeter Barn & Sandy Lane

General Description of Proposal: Common Open Space Major Subdivision Sketch Plan for
Plots this phase MILL RUN - 45 lots

I swear or affirm that the foregoing information and all attachments hereto (now or subsequently provided as part of this application) are true and correct to the best of my knowledge.

Signed: [Signature]
Dated: 6-18-2015

- * Information to be filled out by Planning Department
- * Is the Property in a Watershed Protection area? NO
- * Flood Zone (from FIRM Map): X Taxes paid? yes no

June 17, 2015

TO: Camden County staff and Board Members

From: Garland H. "Gary" Dunstan Jr, Principal of Harbinger Land & Timber LLC; and of Assorted Development Corp.

Subject: Mill Run Subdivision

I have appointed Mark Bissell of Bissell Professional Group to act on my behalf and make decisions for the property we hope to develop as Mill Run. Please make any contacts through Mark and copy me with the correspondence and submittals.

Thank you for working with me, and for all of your help with this project. We hope that Mill Run will be a very nice place to live and one the County will be proud of having.

Sincerely,

A handwritten signature in black ink, appearing to read "Gary Dunstan, Jr.", with a stylized flourish at the end.

Garland H. "Gary" Dunstan, Jr., President
Harbinger Land & Timber, LLC and
Assorted Development Corporation

cc: Mark Bissell

**CAMDEN COUNTY
NORTH CAROLINA**



VICINITY MAP
SCALE: 1" = 5000'

MILL RUN

SOUTH MILLS TOWNSHIP CAMDEN COUNTY NORTH CAROLINA

GENERAL NOTES:

1. PROJECT NAME: MILL RUN SUBDIVISION
2. OWNER/APPLICANT: HARBINGER LAND & TIMBER, LLC
P.O. BOX 4
HARBINGER, NC 27941
3. PROPERTY DATA:
PARCEL ID#: 01-7090-00-07-688, 01-7090-00-17-0117
PRIMARY ADDRESS: SHARON CHURCH ROAD SOUTH MILLS, NC
RECORDED REFERENCES: 01E - 76
PROPERTY ZONING: BASIC RESIDENTIAL R3-1
5. SUBJECT PROPERTY IS LOCATED IN F.I.R.M. ZONE X. REFERENCE F.I.R.M PANEL # 3721709000J, EFFECTIVE DATE: October 5, 2004. <SUBJECT TO CHANGE BY F.E.M.A.>

SHEET INDEX

SHEET	DESCRIPTION
1	COVER SHEET AND SITE LOCATION
2	EXISTING CONDITIONS
3	YIELD PLAN
4	CONSERVATION PLAN
5	PRELIMINARY PLAN

BISSELL
PROFESSIONAL GROUP
Engineers, Planners, Surveyors
and Environmental Specialists

This document is the sole property of BFG, Inc. of Kitty Hawk, North Carolina. The reproduction, in whole or part, or the modification of any detail or design is not to be made without the express written consent of Mark S. Bissell, Principal of BFG, Inc. Copyright 2002.

Bissell Professional Group
Firm License # C-956
3512 North Croatan Highway
Kitty Hawk, NC 27949
(252) 261-3266
FAX (252) 261-1760

MILL RUN
COMMON OPEN SPACE SUBDIVISION
SOUTH MILLS TOWNSHIP CAMDEN COUNTY NORTH CAROLINA
COVER SHEET, NOTES AND LOCATION MAP

NO.	DATE	DESCRIPTION	BY

PRELIMINARY
FOR REVIEW
PURPOSES ONLY

DATE: 5-28-15 SCALE: N/A
 DESIGNED: MSB CHECKED: MSB
 DRAWN: KFW APPROVED: BPG
 SHEET: 1 OF 5
 CAD FILE:
 PROJECT NO: 4562

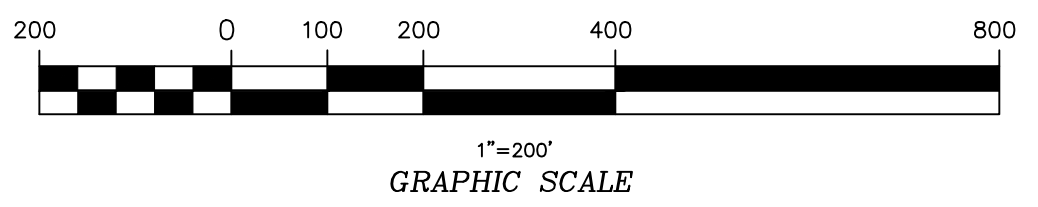
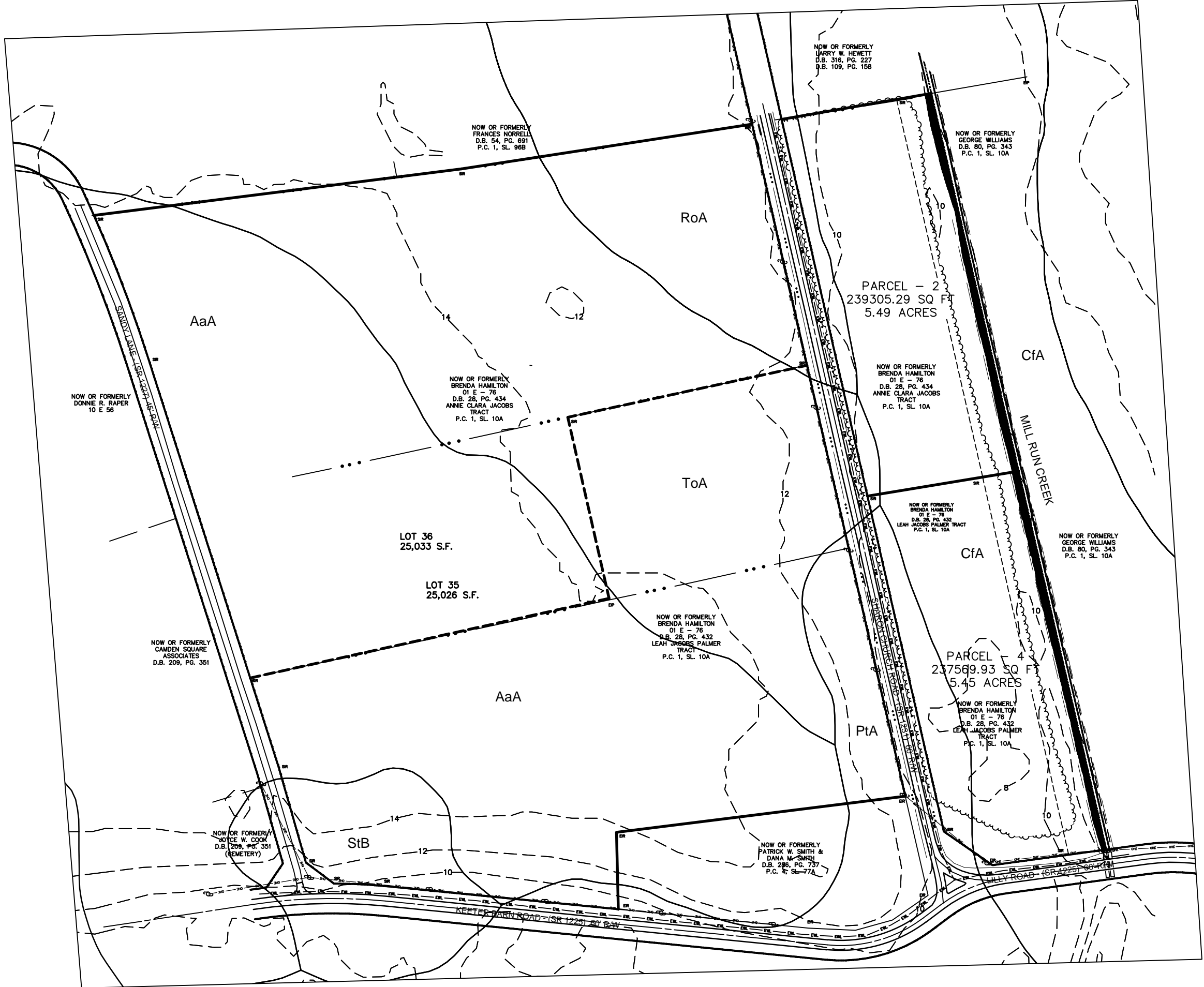

Bissell Professional Group
Firm License # C-956
15727 Ocean Highway
P.O. Box 1066
Kitty Hawk, North Carolina 27949
(252) 261-3266
FAX (252) 261-1760

MILL RUN
COMMON OPEN SPACE SUBDIVISION
SOUTH MILLS TOWNSHIP CAMDEN COUNTY NORTH CAROLINA
EXISTING CONDITIONS PLAN

Table with columns: NO., DATE, REVISIONS DESCRIPTION, BY.

Table with columns: DATE, SCALE, DESIGNED, CHECKED, DRAWN, APPROVED.

SHEET: 2 OF 5
CAD FILE: 457500SK-C3D2
PROJECT NO: 4575

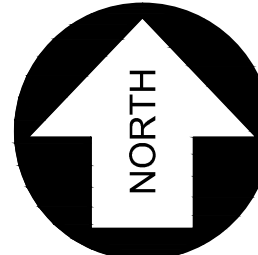
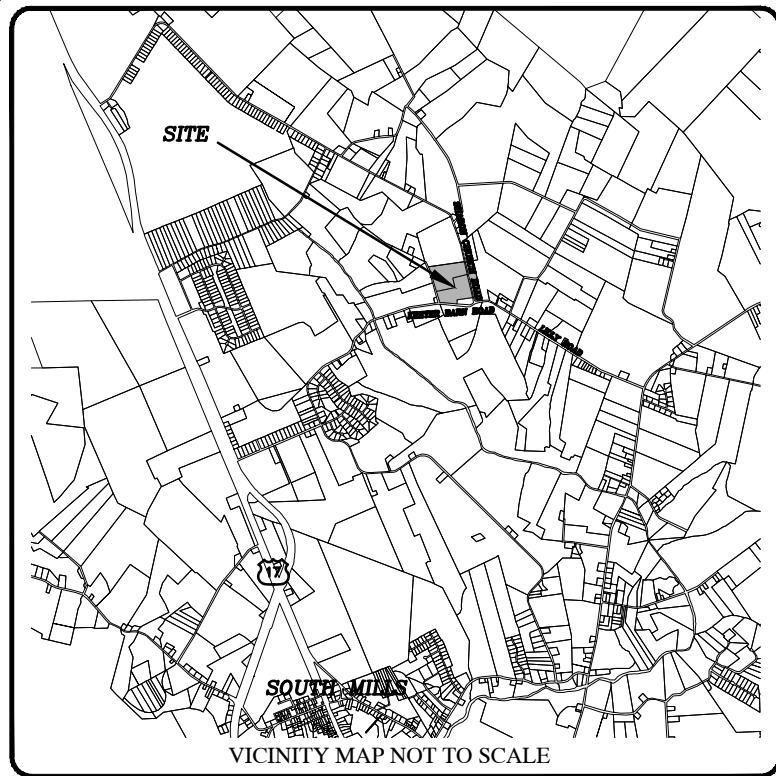

NC NAD83(2011) GRID NORTH

SURVEY LEGEND

ECM	EXISTING CONCRETE MONUMENT
SIR	SET IRON ROD
EIR	EXISTING IRON ROD
EIP	EXISTING IRON PIPE
CP	CALCULATED POINT
M.B.L.	MAXIMUM BUILDING LIMIT
N.T.S.	NOT TO SCALE
P.C.	PLAT CABINET
D.B.	DEED BOOK
SL	SLIDE
SF	SQUARE FEET
AC	ACRES

AREA CALCULATIONS:

TOTAL AREA:	51.89 Ac.
PRIMARY CONSERVATION AREA:	0.61 AC.
NET DEVELOPMENT AREA:	51.28 AC.
5% OPEN SPACE:	2.56 AC.
OPEN SPACE PROVIDED:	3.04 AC.
AREA IN STREETS:	1.67 AC.
AREA AVAILABLE FOR LOTS:	46.57 AC.

PRELIMINARY YIELD PLAN:

- 1 ACRE LOTS IN R-3-1: 37 LOTS
- 2 ACRE LOTS IN R-3-2: 5 LOTS
- TOTAL: 42 LOTS
- 5% C.O.S. BONUS: 2
- OPTIONAL ENDOWMENT FUND BONUS: 2
- YIELD INCLUDING BONUSES: 46
- (BASIS FOR COMMON OPEN SPACE PLAN)



LINE TABLE

LINE	LENGTH	BEARING
L1	60.12	N80° 48' 00"E
L2	119.09	N55° 18' 15"W
L3	204.70	S13° 00' 34"E
L4	155.03	S1° 27' 37"E
L5	70.61	N53° 08' 05"W

CURVE TABLE

CURVE	LENGTH	RADIUS	CHORD	BEARING	DELTA
C1	311.71	2887.29	311.55	N20° 46' 39"W	6° 11' 08"
C2	106.37	1105.00	106.33	N87° 05' 43"W	5° 30' 56"

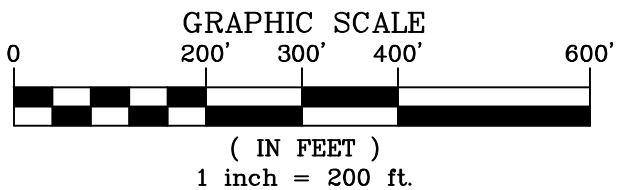

BISSELL
PROFESSIONAL GROUP
Engineers, Planners, Surveyors
and Environmental Specialists

Bissell Professional Group
Firm License # C-956
3512 North Carolina Highway
P.O. Box 102
Kitty Hawk, North Carolina 27949
(252) 261-3266
FAX (252) 261-1760

This document is the sole property of BPG, Inc. of Kitty Hawk, North Carolina. The reproduction, in whole or part, or the modification of any detail or design, is not to be made without the express written consent of BPG, Inc. Copyright 2008.

MILL RUN
PROPERTY OF BRENDA HAMILTON
PRELIMINARY YIELD PLAN

SOUTH MILLS TOWNSHIP CAMDEN COUNTY NORTH CAROLINA

REVISIONS

NO.	DATE	DESCRIPTION	BY

DATE: 05-05-15	SCALE: 1"=200'
DESIGNED: MSB	CHECKED: MSB
DRAWN: KFW	APPROVED: BPG
SHEET: 3 OF 5	
CAD FILE: 457500YP1	
PROJECT NO: 4575	

DEVELOPMENT SUMMARY

TOTAL AREA OF TRACT:	51.89 AC.
C.O.E. JURISDICTIONS:	0.61 AC.
NET AREA FOR COMPUTATIONS	51.28 AC.
10% FOR ROADS	5.13 AC.
	46.15 AC.
REQUIRED OPEN SPACE (50% OF 46.15):	23.08 AC.
PLUS C.O.E. JURISDICTION:	0.61 AC.
TOTAL REQUIRED OPEN SPACE:	23.69 AC.

MINIMUM LOTS SIZE = 22,871 SQ. FT.



SOIL TYPES	
AaA	ALTAVISTA FINE SANDY LOAM
CFA	CAPE FEAR SILT LOAM
PtA	PORTSMOUTH FINE SANDY LOAM
RoA	ROANOKE SILT LOAM
ToA	TOMOTLEY FINE SANDY LOAM

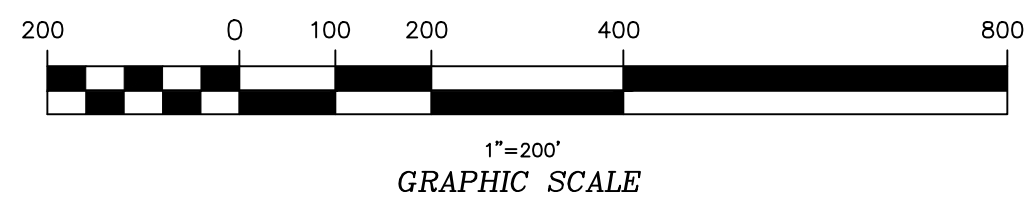

CONSERVATION AREA SUMMARY		
	PRIMARY CONSERVATION AREAS:	0.61 AC.
	SECONDARY CONSERVATION AREAS:	23.48 AC.
	TOTAL CONSERVATION AREAS:	24.09 AC.



BISSELL
PROFESSIONAL GROUP
Engineers, Planners, Surveyors
and Environmental Specialists

Bissell Professional Group
Firm License # C-956
1727 W. Garden Highway
P.O. Box 1066
Kitty Hawk, North Carolina 27949
(252) 261-3266
FAX (252) 261-1760

This document is the sole property of BPG, Inc. or Kitty Hawk, North Carolina. The user agrees to indemnify and hold BPG, Inc. harmless from all claims, damages, and expenses, including reasonable attorneys' fees, without the express written consent of Mark S. Bissell, Principal of BPG, Inc. Copyright 2008.

PROJECT:
**MILL RUN
COMMON OPEN SPACE SUBDIVISION**
SOUTH MILLS TOWNSHIP CAMDEN COUNTY NORTH CAROLINA
PRELIMINARY CONSERVATION PLAN

NO.	DATE	DESCRIPTION	BY

DESIGNED: BPG	CHECKED: MSB
DRAWN: KFW	APPROVED: BPG

DATE: 06-08-15	SCALE: 1"=200'
SHEET: 4 OF 5	
CAD FILE: 457500SK-C3D2	
PROJECT NO: 4575	

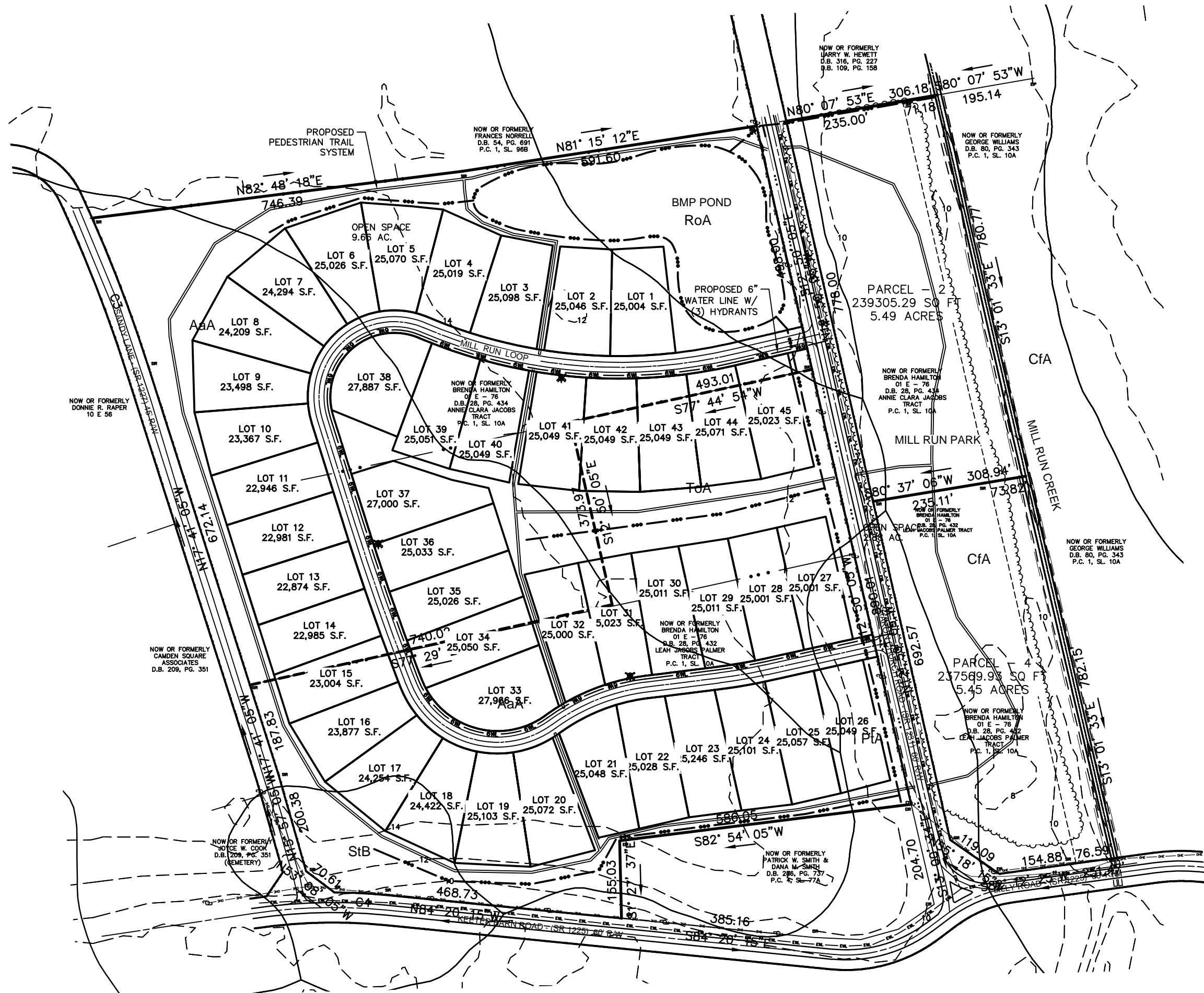

COMMON OPEN SPACE (CONSERVATION) PLAN
 CONVENTIONAL LOTS PER YIELD PLAN: 42
 BONUS LOTS FOR C.O.S. PLAN: 2
 BONUS LOTS FOR ENDOWMENT FUND: 2

CONSERVATION LOTS ALLOWED: 46
 CONSERVATION LOTS PROPOSED: 45

ACTIVE RECREATION AREAS
 REQUIRED = 2000 S.F. X 45 = 90,000 S.F.
 POND AREA: 120,000 S.F.±
 TRAIL AREA: 29,000 S.F.±
 TOTAL AREA: 149,000 S.F.±

ENDOWMENT FUND
 TOTAL OPEN SPACE = 24.09 AC.
 \$50/AC. X 20 AC. = \$1,000/YEAR
 \$25/AC X 4.09 AC. = \$102/YEAR
 TOTAL \$1,102/YEAR

MIN. FUNDING = 20 X \$1,102 = \$22,040

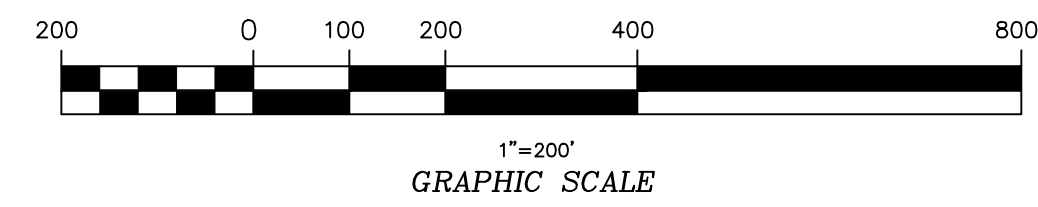

LEGEND

- ROADWAY CENTERLINE
- RIGHT OF WAY
- PROPERTY BOUNDARY
- EXISTING GRADE CONTOUR
- EXISTING TREE LINE
- ADJOINING PROPERTY
- PROPOSED SWALE
- PROPOSED STORMWATER BMP
- PROPOSED ROADWAY
- PROPOSED PEDESTRIAN WALK

BISSELL PROFESSIONAL GROUP
 Engineers, Planners, Surveyors and Environmental Specialists

Bissell Professional Group
 Firm License # C-956
 1727 Elizabethan Highway
 P.O. Box 1065
 Kitty Hawk, North Carolina 27949
 (252) 261-3266
 FAX (252) 261-1760

This document is the sole property of BPG, Inc. of Kitty Hawk, North Carolina. The user of this document is limited to the specific project and site for which it was prepared without the express written consent of BPG, Inc. Copyright 2005.

PROJECT:
 MILL RUN COMMON OPEN SPACE SUBDIVISION
 SOUTH MILLS TOWNSHIP CAMDEN COUNTY NORTH CAROLINA
 PRELIMINARY SUBDIVISION PLAN

NO.	DATE	DESCRIPTION	BY

DATE: 06-08-15	SCALE: 1"=200'
DESIGNED: BPG	CHECKED: MSB
DRAWN: KFW	APPROVED: BPG
SHEET: 5 OF 5	
CAD FILE: 457500SK-C3D2	
PROJECT NO: 4575	



The Coastal Experts

DEVELOPMENT IMPACT STATEMENT

FOR

Mill Run

45-lot Common Open Space (Conservation) Subdivision

South Mills Township

OWNER/DEVELOPER:

Harbinger Land & Timber, LLC

P.O. Box 4

Harbinger, NC 27941

June 30, 2015

**PRELIMINARY
For Review Purposes Only**

MILL RUN

TABLE OF CONTENTS

LOCATION MAP AND DEVELOPMENT PLAN

PART 1:	PHYSICAL ANALYSIS
	<ul style="list-style-type: none">• Expected Housing Unit Types• Projected Values• Phasing of Project
PART 2:	MARKET ANALYSIS
	<ul style="list-style-type: none">• Market Area & Plan• Supply and Demand Considerations• Development Profile
PART 3:	ENVIRONMENTAL IMPACT
	<ul style="list-style-type: none">• Estimated Water Consumption• Wastewater Treatment Disposal• Stormwater
PART 4:	FISCAL ANALYSIS
	<ul style="list-style-type: none">• Estimated Total Property Valuation• Tax Revenue (Annual)• Other Revenue Sources
PART 5:	TRAFFIC ANALYSIS
	<ul style="list-style-type: none">• General Site and Land Use• Trip Generation• Directional Distribution• Volume Impact

MILL RUN

PART 1

PHYSICAL ANALYSIS

**PHYSICAL ANALYSIS
FOR
MILL RUN**

Expected Housing Unit Types:

MILL RUN will be a common open space (conservation) subdivision with approximately 45 lots situated within substantial community open space areas. Typical houses at MILL RUN will range from 2,000 to 2,500 square feet. Houses will be a mixture of one- and two-story structures, and will typically have a minimum of two bathrooms with three or four bedrooms. A mixture of modern-styled upscale homes is anticipated, similar to the representative models that are presented on the following pages.

Projected Values:

The developer anticipates selling individual lots to a preferred builder or builders, who will in turn build out the development. The developer estimates the total land value at the time of sale to be between \$2.25 million and \$2.7 million; at build-out, the developer estimates that the subdivision's total valuation will be in the range of \$13.5 million to \$17 million, as further shown in the fiscal impact section of this report.

Phasing of the Project:

The developer anticipates building the infrastructure in a single phase. Erosion control and stormwater management facilities will be constructed first, followed by site grading and roadway construction, and lastly, the addition of site amenities such as trails and landscaping. Based on a review of the history of other projects in the area, and on the expectations of the developer in the current housing market in the area, it is anticipated that the subdivision will build out in about three years.



First Floor - 1,493 sq. ft.
Second Floor - 927 sq. ft.
Total Heated - 2,420 sq. ft.
Garage - 528 sq. ft.
Opt Dormer - 68 sq. ft.



First Floor - 898 sq. ft.
Second Floor - 1,344 sq. ft.
Total Heated - 2,242 sq. ft.
Garage - 495 sq. ft.



First floor - 2,107 Sq. Ft.
FROG - 345 Sq. Ft.
Total Heated - 2,452 Sq. Ft.
Garage - 462 Sq. Ft.
Opt. Sunroom - 224 Sq. Ft.
Opt. FROG half bath - 25 Sq. Ft.
Opt. FROG full bath - 86 Sq. Ft.



First Floor - 1,664 sq. ft.
FROG - 382 sq. ft.
Total Heated - 2,046 sq. ft.
Opt. FROG Full Bath - 112 sq. ft.
Garage - 418 sq. ft.
Opt. Mater Suite - 68 sq. ft.

MILL RUN

PART 2

MARKET ANALYSIS

**HOUSING MARKET ANALYSIS
FOR
MILL RUN**

Market Area and Plan:

The primary target market will be two-fold. There appears to be a strong market of retirees who want to be in the Camden County and particularly the South Mills area of the county. Second, there is a opportunity to capture some of the “move-up” housing market for those who prefer the rural environment of northeastern North Carolina to what is offered in Tidewater Virginia. The developer plans, in concert with the preferred builder, to offer attractive and affordable builder packages in Mill Run.

Supply and Demand Considerations:

Camden County’s housing market has been in somewhat of a slump for the past several years, but there are now signs of increasing interest in new property ownership in the area. New residents not only bring income and wealth to the area, but they create the demand for housing - which brings construction jobs to the county. MILL RUN is designed to provide a small, quiet upscale community with strict restrictive covenants for permanent residents of Camden County.

Development Profile:

MILL RUN will be a development of well-coordinated single-family dwellings. The project is anticipated to reach build out in approximately three years. Strict covenants and required approval of construction by an architectural review committee will ensure that the homes in MILL RUN are upscale in design and size, with homes ranging from 2,000 to 2,500 square feet. Existing woodlands will be preserved, and a community trail system will wind through the open space areas for the enjoyment of the residents. The development’s design pulls homes away from existing state roads; vegetative screening will also increase the community’s overall aesthetic value. The preliminary subdivision plan for this development is shown on the following page.

DEVELOPMENT SUMMARY

TOTAL AREA OF TRACT: 51.89 AC.
 C.O.E. JURISDICTIONS: 0.61 AC.
 NET AREA FOR COMPUTATIONS: 51.28 AC.
 10% FOR ROADS: 5.13 AC.
 REQUIRED OPEN SPACE (50% OF 46.15): 46.15 AC.
 PLUS C.O.E. JURISDICTION: 23.08 AC.
 TOTAL REQUIRED OPEN SPACE: 0.61 AC.
 23.69 AC.
 MINIMUM LOTS SIZE = 22,871 SQ. FT.

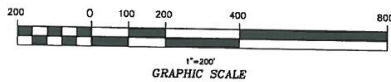
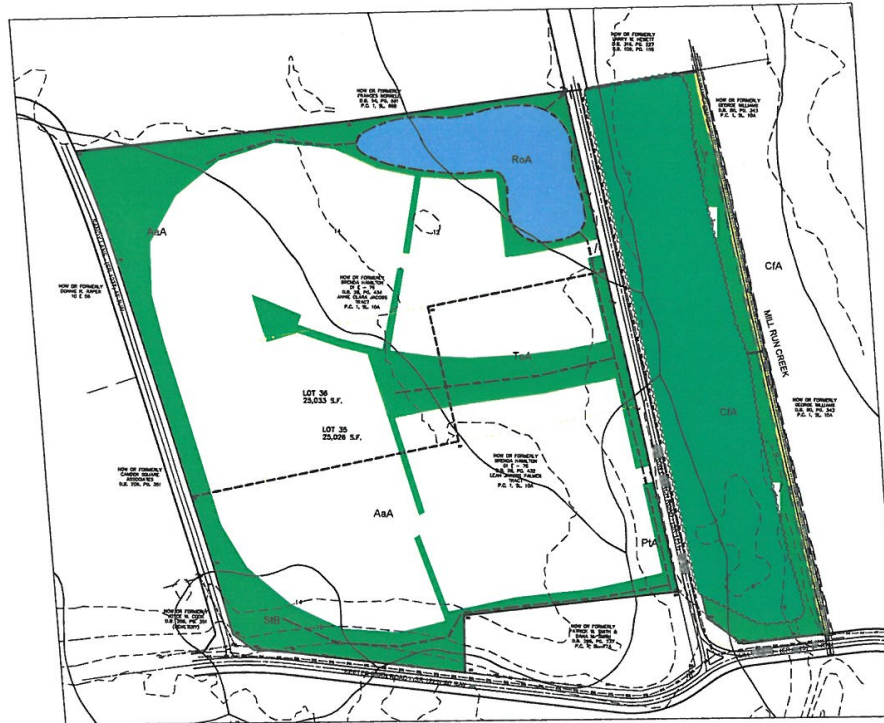

SOIL TYPES	
AaA	ALTAMSTA FINE SANDY LOAM
CFA	CAPE FEAR SILT LOAM
PLA	PORTSMOUTH FINE SANDY LOAM
RoA	ROANOKE SILT LOAM
ToA	TOMTLEY FINE SANDY LOAM

CONSERVATION AREA SUMMARY	
PRIMARY CONSERVATION AREAS:	0.61 AC.
SECONDARY CONSERVATION AREAS:	23.48 AC.
TOTAL CONSERVATION AREAS:	24.09 AC.

BISSELL
 Professional Group
 5700 University Blvd., Suite 200
 Raleigh, NC 27613
 (919) 871-3300
 (919) 871-3308
 FAX (919) 241-1100

MILL RUN
 COMMON OPEN SPACE SUBDIVISION
 SOUTH HILLS TOWNSHIP CAMDEN COUNTY NORTH CAROLINA
 PRELIMINARY CONSERVATION PLAN

NO.	DATE	DESCRIPTION	BY

DATE: 06-08-15 SCALE: 1"=200'
 DRAWN: BPG CHECKED: MSB
 REVISED: NFW
 SHEET: 4 OF 5
 CAD FILE: 457500SK-C3D2
 PROJECT NO: 4575

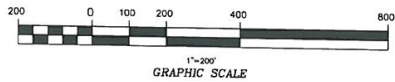

COMMON OPEN SPACE (CONSERVATION) PLAN
 CONVENTIONAL LOTS PER YIELD PLAN: 42
 BONUS LOTS FOR C.O.S. PLAN: 2
 BONUS LOTS FOR ENDOWMENT FUND: 2
 CONSERVATION LOTS ALLOWED: 46
 CONSERVATION LOTS PROPOSED: 45

ACTIVE RECREATION AREAS
 REQUIRED = 2000 S.F. X 45 = 90,000 S.F.
 POND AREA: 120,000 S.F.±
 TRAIL AREA: 29,000 S.F.±
 TOTAL AREA: 149,000 S.F.±

ENDOWMENT FUND
 TOTAL OPEN SPACE = 24.09 AC.
 \$50/AC. X 20 AC. = \$1,000/YEAR
 \$25/AC. X 4.09 AC. = \$102/YEAR
 TOTAL \$1,102/YEAR
 MIN. FUNDING = 20 X \$1,102 = \$22,040

LEGEND	
	ROADWAY CENTERLINE
	RIGHT OF WAY
	PROPERTY BOUNDARY
	EXISTING GRADE CONTOUR
	EXISTING TREE LINE
	ADJOINING PROPERTY
	PROPOSED SWALE
	PROPOSED STORMWATER BMP
	PROPOSED ROADWAY
	PROPOSED PEDESTRIAN WALK

BISSELL
 PROFESSIONAL GROUP
 and Environmental Specialists
 2000 West 20th Street, Suite 200
 Cary, NC 27513
 Phone: (919) 237-2268
 Fax: (919) 237-2110
 www.bissellgroup.com

MILL RUN
 COMMON OPEN SPACE SUBDIVISION
 SOUTH MILLS TOWNSHIP, GARDEN COUNTY, NORTH CAROLINA
 PRELIMINARY SUBDIVISION PLAN

NO.	DATE	DESCRIPTION	BY

DATE: 06-08-15 SCALE: 1"=200'
 DRAWN BY: BPG CHECKED BY: MSB
 DESIGNED BY: KFW
 SHEET: 5 of 5
 CAD FILE: 457500SK-C3D2
 PROJECT NO: 4575

MILL RUN

PART 3

ENVIRONMENTAL IMPACT

**ENVIRONMENTAL IMPACT
(WATER AND WASTEWATER)**

MILL RUN is designed to be a 45-lot residential subdivision, with water supply to be provided by South Mills Water Association, and with each lot to be served by an individual septic system, since the property's soils, discussed in more detail below, are provisionally suitable for septic system installation. There is an existing 6-inch waterline on Keeter Barn Road that will be tapped and extended into the subdivision to provide both potable water distribution and fire protection to the development.

Estimated Water Consumption and Sewage Disposal:

The basis of design for the wastewater systems for the houses in this development will be 120 gallons per day per bedroom, in accordance with state rules, with three and four bedrooms per house. Since the subdivision will utilize South Mills water, the basic design flow for water per house will be 400 gallons, as prescribed by the NC Public Water Supply Section. The basis of design for the water and sewer facilities for this project is therefore as follows:

Water: 45 Single Family Dwellings at 400 GPD/Dwelling =	18,000 GPD
Wastewater: 45 Dwellings at 3.5 BR average@ 120 GPD/BR =	18,900 GPD

Wastewater Disposal:

The Camden County soils mapping shows the largest portion of the site characterized by Altavista fine sandy loam, a moderately well-drained soil, and Tomotley fine sandy loam, which is somewhat less well drained. Albemarle Regional Health Services has performed a preliminary site evaluation, testing the site for on-site wastewater system suitability in representative areas, and determined that the majority of the soils are provisionally suitable for development. The developer plans to install individual septic systems for the lots within the development. The ARHS reports for the testing that has been performed are included on the following pages.

Stormwater:

Collector swales and infiltration swales will be installed as needed along lot lines. The soils are relatively sandy and the development will be a low-density project. A stormwater detention pond will be constructed to detain the difference between pre- and post-development runoff. The details of the stormwater plan will be designed in consultation with Camden County's Engineer and its stormwater regulations, as well as those promulgated by the North Carolina Division of Energy, Minerals and Land Resources (NCDEMLR).

MILL RUN

PART 4

FISCAL ANALYSIS

**FISCAL IMPACT STATEMENT
FOR
MILL RUN**

The following is a summary of the details of the anticipated Fiscal Impact for Mill Run , for the 45 lots proposed as part of the application for sketch plan approval:

A. Estimated Total Property Valuation, Pre-Buildout:

45 lots @ average valuation \$50-60,000/lot (use \$55,000) = \$2,475,000

Estimated Total Property Valuation, Buildout:

45 lots/homes average valuation \$300-380,000/home (use \$340,000 average) = \$15,300,000

B. Tax Revenue (Annual):

The positive operational impact on Currituck County at full buildout is estimated to be as follows:

Ad Valorem Tax: \$0.68/100 x \$15,300,000	= \$ 104,040
Fire Tax: 0.01/100 x \$15,300,000	= \$ 1,530

TOTAL, Estimated Annual Tax Revenue: = \$105,570

C. Other Revenue Sources:

Transfer Taxes on Lot Sales: 1.0% x \$2,475,000	= \$ 24,750
Transfer Taxes on Home Sales: 1.0% x \$15,300,000	= \$153,000
Revenue Stamps: 0.02% x (\$2,475,000 + \$15,300,000)	= \$ 3,555
Subtotal:	= \$181,305

Development Review Fees: 45 lots @ \$400/lot	= \$ 18,000
Stormwater Review Fees:	= \$ 6,000
Building Permit Fees: 45 houses @ \$1,300/house average	= \$ 58,500
Subtotal:	\$ 82,500

TOTAL, Estimated Other Revenue: = \$263,805

MILL RUN

PART 5

TRAFFIC ANALYSIS

**TRAFFIC IMPACT ANALYSIS
FOR
MILL RUN**

- A. General Site and Land Use Description:** The proposed project is to be developed on a 52+/-acre site fronting on SR 1225 and SR 1231 northeast of the South Mills community. The site will have 45 single-family houses.
- B. Trip Generation:** Using the standard NCDOT total of approximately 10 trips per house per day, the project at buildout is anticipated to generate the following traffic volume at buildout, anticipated for 3 - 4 years after final plat recordation.

45 dwelling units @ 10 trips/day: 450 trips/day

- C. Directional Distribution of Vehicle Trips:** Of the projected 450 daily trips, it is estimated that approximately 40 % will travel north along Sharon Church (SR 1231) toward US 17, about 30% will travel west toward South Mills along Keeter Barn Road (SR 1225), and the other 30% will travel east on Keeter Barn toward Moyock. This results in the following daily traffic additions to these existing roadways, as shown on the attached NCDOT traffic volume map:

- Sharon Church Road (SR 1231): 180 trips/day
 - Keeter Barn Road (SR 1225) –West: 135 trips/day
 - Keeter Barn Road (SR 1225) – East: 135 trips/day
- Total: 450 trips/day

D. Volume Impact

The North Carolina Department of Transportation has very limited information on the volumes of existing traffic on the secondary roads in the vicinity of the proposed development. The latest data available, from 2013, shows average daily traffic volumes on similar roads in the area ranging from about 300 to about 600 vehicles per day. Latest available traffic counts on US 17 show approximately 14,000 vehicles per day for a section of the highway north of the project site. The additional traffic volume will be less than 1-1/2% of the total current traffic volume on US 17.

The addition of 135 to 180 trips per day on the secondary roads in the vicinity of the development site is not expected to lower the levels of service on these existing lightly-traveled roadways.

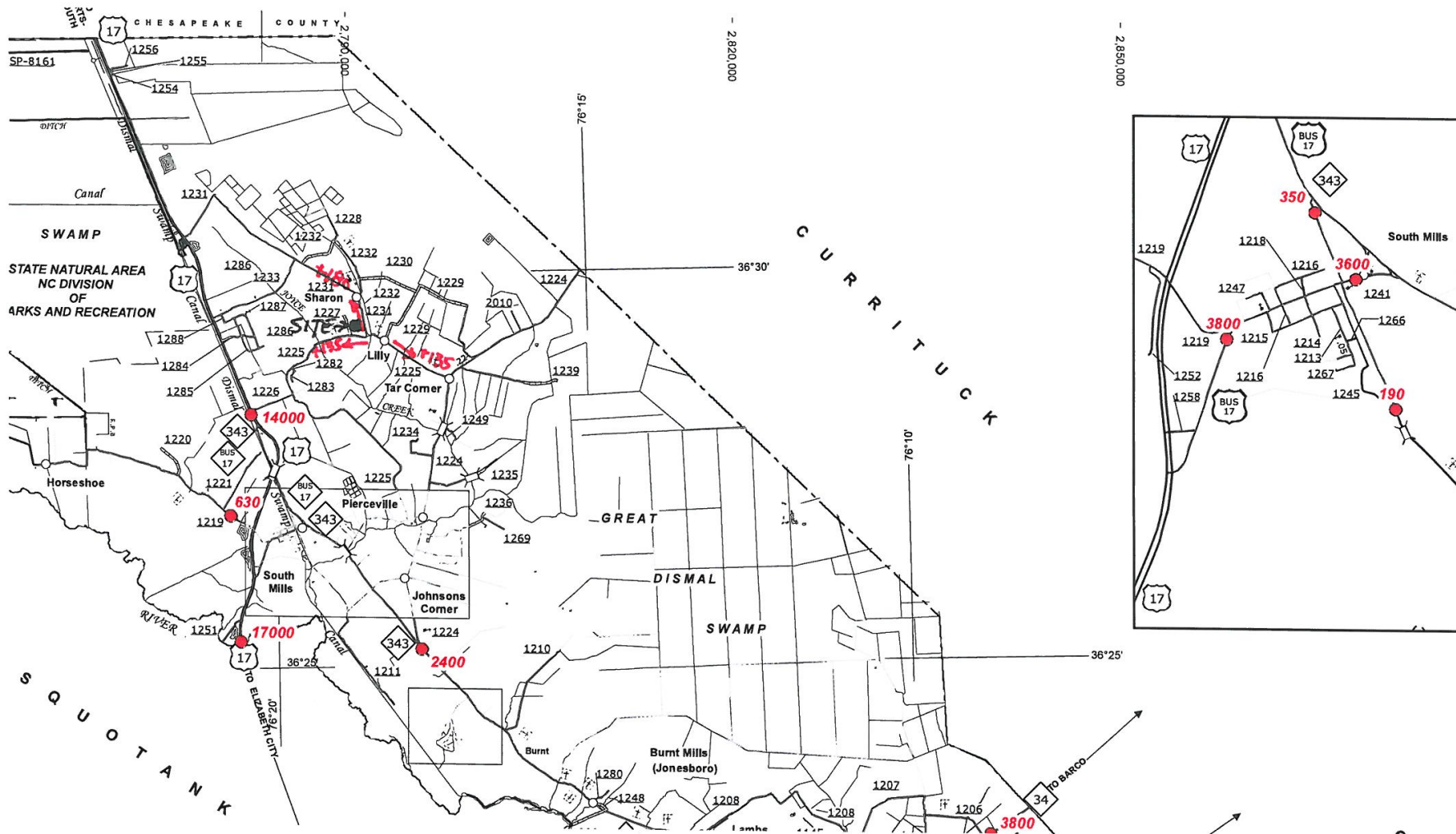

**Camden County Board of Commissioners
AGENDA ITEM SUMMARY SHEET**

Item Number: 5.A

New Business

Meeting Date: September 8th, 2015

Attachments: (7 Pages)

**Submitted By: Lisa Anderson
Tax Administrator,**

ITEM TITLE: Monthly Tax Report

MOTION MADE BY:	
S. Duckwall	
G. Meiggs	
M. McLain	
C. Riggs	
T. White	
NO MOTION	
VOTE:	
S. Duckwall	
G. Meiggs	
M. McLain	
C. Riggs	
T. White	
ABSENT	
RECUSED	

SUMMARY:

Monthly Tax Report for July 2015

RECOMMENDATION:

Review & Approve

**MONTHLY REPORT OF THE TAX ADMINISTRATOR TO THE
CAMDEN COUNTY BOARD OF COMMISSIONERS**

July '15

OUTSTANDING TAX DELINQUENCIES BY YEAR

<u>YEAR</u>	<u>REAL PROPERTY</u>	<u>PERSONAL PROPERTY</u>
2014	197,572.44	7,143.68
2013	73,147.81	8,516.88
2012	31,869.58	10,984.94
2011	17,966.79	8,129.14
2010	17,844.21	6,447.94
2009	7,238.84	6,069.27
2008	6,133.35	6,309.30
2007	6,114.92	9,813.87
2006	1,996.46	14,493.82
2005	1,690.71	26,446.67

July '15

TOTAL REAL PROPERTY TAX UNCOLLECTED	361,575.11
TOTAL PERSONAL PROPERTY UNCOLLECTED	104,355.51
TEN YEAR PERCENTAGE COLLECTION RATE	99.31%
COLLECTION FOR 2015 vs. 2014	22,473.67 vs. 28,580.48

LAST 3 YEARS PERCENTAGE COLLECTION RATE

2014	96.98%
2013	98.84%
2012	99.40%

THIRTY LARGEST UNPAID ACCOUNTS

SEE ATTACHMENT "A"

THIRTY OLDEST UNPAID ACCOUNTS

SEE ATTACHMENT "B"

EFFORTS AT COLLECTION IN THE LAST 30 DAYS

**ENDING July 2015
BY TAX ADMINISTRATOR**

- 70 NUMBER DELINQUENCY NOTICES SENT
- 49 FOLLOWUP REQUESTS FOR PAYMENT SENT
- 15 NUMBER OF WAGE GARNISHMENTS ISSUED
- 0 NUMBER OF BANK GARNISHMENTS ISSUED
- 32 NUMBER OF PERSONAL PHONE CALLS MADE BY TAX ADMINISTRATOR TO DELINQUENT TAXPAYER
- 0 NUMBER OF PERSONAL VISITS CONDUCTED (COUNTY OFFICES)
- 3 PAYMENT AGREEMENTS PREPARED UNDER AUTHORITY OF TAX ADMINISTRATOR
- 0 NUMBER OF PAYMENT AGREEMENTS RECOMMENDED TO COUNTY ATTORNEY
- 0 NUMBER OF CASES TURNED OVER TO COUNTY ATTORNEY FOR COLLECTION (I.D. AND STATUS)
- 0 REQUEST FOR EXECUTION FILES WITH CLERK OF COURTS
- 0 NUMBER OF JUDGMENTS FILED

Roll	Parcel Number	Unpaid Amount	YrsDlq	Taxpayer Name	City	Property Address
R	03-8971-00-12-0477.0000	18,187.53	1	GILBERT WAYNE OVERTON &	SHILOH	187 THOMAS POINT RD
R	01-7080-00-17-0129.0000	14,367.66	1	CAMDEN SQUARE ASSOCIATES	SOUTH MILLS	
R	01-7989-00-01-1714.0000	9,660.86	1	CHARLES MILLER HEIRS	SOUTH MILLS	HORSESHOE RD
R	02-8923-00-19-3774.0000	9,070.52	1	HALSTEAD VENTURE PARTNERS, LLC	CAMDEN	431 158 US W
R	02-8944-00-31-2148.0000	7,239.15	1	CARL HARRINGTON	CAMDEN	150 SAND HILLS RD
R	03-8899-00-45-2682.0000	7,095.06	1	SEAMARK INC.	SHILOH	HOLLY RD
R	01-7998-01-08-8621.0000	6,199.91	2	WILLIE L. TURNER ETAL	SOUTH MILLS	1289 343 HWY N
R	03-8972-00-51-8423.0000	5,904.26	1	BRITTON OVERTON	SHILOH	103 WESLEY RD
R	02-8945-00-54-1099.0000	5,705.20	1	GERTIE LEE & JONOLA T ROUNTREE	CAMDEN	263 BELCROSS RD
R	03-8943-04-74-3506.0000	5,428.11	1	ELLIOTT & DONNA JACOBS	SHILOH	117 SUNSET AVE
R	03-8953-04-81-9832.0000	5,259.29	3	MAIDIA S. CECIL HEIRS	SHILOH	113 TROTMAN RD
R	01-8000-00-36-9596.0000	4,877.21	1	EULA B. JOYNER	SOUTH MILLS	TROTTERS WAY
R	02-8945-00-41-2060.0000	4,265.13	1	LABELLE ETHERIDGE SR.	CAMDEN	168 BUSHELL RD
R	03-8990-00-08-7291.0000	4,066.47	1	JAMES E RHODES	SHILOH	111 CATALAN DR
R	03-8889-00-48-0580.0000	3,863.73	1	HECTOR C. PALALAY & MILAGROS O	SHILOH	113 SAILBOAT RD
R	03-8952-01-49-1090.0000	3,621.40	1	DRACHMA, INC & SIMSON BAAI, LLC	SHILOH	343 HWY S
R	01-7080-00-62-1977.0000	3,495.60	8	SANDERS CROSSING OF CAMDEN CO	SOUTH MILLS	117 OTTERS PL
R	03-8961-00-58-4506.0000	3,371.91	1	WARREN DEAN RIGGS	SHILOH	110 DRIFTWOOD DR
R	03-8965-00-44-7928.0000	3,150.59	1	WHALON & KATHLEEN MCCULLEN	SHILOH	404 SANDY HOOK RD
R	01-7998-01-08-6797.0000	3,131.98	4	EDWARD E. HARRIS JR.	SOUTH MILLS	1295 343 HWY N
R	02-8936-00-21-4428.0000	3,018.28	2	CAROLYN MCDANIEL	CAMDEN	SCOTLAND RD
R	03-8971-00-23-2253.0000	3,016.38	1	ABODE OF CAMDEN, INC.	SHILOH	187 C THOMAS POINT RD
R	03-8964-00-40-9957.0000	3,000.55	1	LASALLE SEARS HEIRS	SHILOH	291 BARTLETT RD
R	01-7989-04-60-3728.0000	2,942.77	1	JAMES R. & SHIRLEY GRIFFIN	SOUTH MILLS	208 CANAL DR
R	03-8962-00-56-7217.0000	2,914.53	1	TONYA HUGHES HARRIS	SHILOH	253 WICKHAM RD
R	01-7989-04-90-6715.0000	2,900.35	4	ANDREW FEREBEE HEIRS	SOUTH MILLS	1334 343 HWY N
R	02-8934-04-61-9891.0000	2,864.33	1	WILLIAM EDGAR STAPLES	CAMDEN	244 COUNTRY CLUB RD
R	02-8934-01-07-9286.0000	2,705.59	1	CAMDEN SALES & SERVICE	CAMDEN	166 158 US W
R	02-8934-04-71-8470.0000	2,700.25	1	JAMES MILTON JONES ETAL	CAMDEN	267 COUNTRY CLUB RD
R	02-8943-01-26-9508.0000	2,570.16	1	FITZHERBERT, ADELL & BARBARA	CAMDEN	108 RIDGE RD

08/03/15 08:57:56

Delinquencies Top-30 Unpaid

1
Real
Attachment "A"

Roll	Parcel Number	YrsDlq	Unpaid Amount	Taxpayer Name	City	Property Address
R	03-8899-00-45-2682.0000	10	7,095.06	SEAMARK INC.	SHILOH	HOLLY RD
R	01-7998-01-08-8621.0000	10	6,199.91	WILLIE L. TURNER ETAL	SOUTH MILLS	1289 343 NC N
R	03-8943-04-93-8214.0000	10	2,287.69	L. P. JORDAN HEIRS	SHILOH	108 CAMDEN AVE
R	01-7999-00-32-3510.0000	10	1,928.53	LEAH BARCO	SOUTH MILLS	195 BUNKER HILL RD
R	03-8952-00-95-8737.0000	10	1,908.86	AUDREY TILLET	SHILOH	171 NECK RD
R	01-7090-00-60-5052.0000	10	962.62	JOE GRIFFIN HEIRS	SOUTH MILLS	117 GRIFFIN RD
R	02-8955-00-13-7846.0000	10	659.94	MARIE MERCER	CAMDEN	IVY NECK RD
R	02-8936-00-24-7426.0000	10	633.65	BERNICE PUGH	CAMDEN	113 BOURBON ST
R	03-9809-00-45-1097.0000	10	260.40	MICHAEL OBER	SHILOH	CENTERPOINT RD
R	01-7090-00-95-5262.0000	10	255.08	JOHN F. SAWYER HEIRS	SOUTH MILL	OLD SWAMP RD
R	03-8980-00-61-1968.0000	10	218.26	WILLIAMSBURG VACATION	SHILOH	CAMDEN POINT RD
R	03-9809-00-17-2462.0000	10	141.61	TODD ALLEN RIGGS	SHILOH	LITTLE CREEK RD
R	01-7999-00-12-8596.0000	9	1,623.08	MOSES MITCHELL HEIRS	SOUTH MILLS	165 BUNKER HILL RD
R	01-7989-04-60-1954.0000	9	1,129.11	CHRISTINE RIDDICK	SOUTH MILLS	105 BLOODFIELD RD
R	03-8899-00-37-0046.0000	9	162.23	ELIZABETH LONG	SHILOH	HIBISCUS
R	01-7989-00-01-1714.0000	8	9,660.86	CHARLES MILLER HEIRS	SOUTH MILLS	HORSESHOE RD
R	02-8945-00-41-2060.0000	8	4,265.13	LASELLE ETHERIDGE SR.	CAMDEN	168 BUSHELL RD
R	01-7080-00-62-1977.0000	8	3,495.60	SANDERS CROSSING OF CAMDEN CO	SOUTH MILLS	117 OTTERS PL
R	02-8934-04-71-8470.0000	8	2,700.25	JAMES MILTON JONES ETAL	CAMDEN	267 COUNTRY CLUB RD
R	01-7988-00-91-0179.0001	8	1,918.10	THOMAS L. BROTHERS HEIRS	SOUTH MILLS	
R	02-8935-01-19-4055.0000	8	1,219.71	ANDERSON CARTWRIGHT SR.	CAMDEN	271 SLEEPY HOLLOW RD
R	01-7988-00-14-1370.0000	8	847.10	ISAAC COSTON	SOUTH MILLS	NORTH SIDE RD
R	02-8935-03-40-3652.1000	8	782.56	HOWARD DAVENPORT	CAMDEN	117 GUMBERRY RD
R	03-8962-00-50-0273.0000	8	764.31	DAISEY WILLIAMS BURNHAM	SHILOH	RAYMONS CREEK RD
R	01-7998-00-57-2800.1000	8	427.45	TINA RENEE LEARY	SOUTH MILLS	111 LINTON RD
R	01-7989-04-60-1568.0000	7	965.01	EMMA BRITE HEIRS	SOUTH MILLS	116 BLOODFIELD RD
R	03-8971-00-12-0477.0000	6	18,187.53	GILBERT WAYNE OVERTON &	SHILOH	187 THOMAS POINT RD
R	02-8945-00-54-1099.0000	6	5,705.20	GERTIE LEE & JONOLA T ROUNTREE	CAMDEN	263 BELCROSS RD
R	03-8953-04-81-9832.0000	6	5,259.29	MAIDIA S. CECIL HEIRS	SHILOH	113 TROTMAN RD
R	03-8990-00-08-7291.0000	6	4,066.47	JAMES E RHODES	SHILOH	111 CATALAN DR

08/03/15 08:57:56

Delinquencies Top-30 Oldest

1
Read Attachment "B"

Roll	Parcel Number	Unpaid Amount	YrsDlq	Taxpayer Name	City	Property Address
P	0001709	1,531.32	6	JOHN MATTHEW CARTE	CAMDEN	158 HWY
P	0002482	1,349.80	1	MASTEC NORTH AMERICA	CAMDEN	
P	0001046	1,110.60	10	THIEN VAN NGUYEN	SHILOH	133 EDGEWATER DR
P	0000738	1,092.13	4	LESLIE ETHERIDGE JR	CAMDEN	431 158 US W
P	0001538	798.61	7	JEFFREY EDWIN DAVIS	HERTFORD	MIC MAC TRAIL
P	0002342	789.69	1	ASSOCIATED TAX APPRAISERS		
P	0001072	778.93	10	PAM BUNDY	SHILOH	105 AARON DR
P	0001883	655.29	4	DUNG LE TRAN	SHILOH	255 SAILBOAT ROAD
P	0001739	655.07	4	COAST TO COAST POWDER COATING	CAMDEN	330 158 HWY E
P	0001827	652.02	1	KAREN BUNDY	CAMDEN	431 158 US W
P	0001695	547.68	3	GARY STEWART ELKINS	CAMDEN	150 158 HWY W
P	0000352	443.65	9	ROBERT F. NERNEY	ELIZABETH CITY	107 SMALL DRIVE
P	0001230	411.11	3	JAMES NYE	SOUTH MILLS	101 ROBIN CT W
P	0001116	409.86	4	AL JORDAN	CAMDEN	390 158 HWY W
P	0000846	405.20	3	TOAN TRINH	SHILOH	229 SAILBOAT RD
P	0001905	340.08	4	AAR CORPORATION ETAL	SOUTH MILLS	211 FLYING TIGER RD
P	0000248	326.53	10	ROBERT H. OWENS	CAMDEN	363 # 15
P	0001227	322.05	9	THUAN NGOC TRAN	SHILOH	257 SAILBOAT RD
P	0000956	314.49	10	HUNG PHI LE	SHILOH	103 EDGEWATER DR
P	0000010	278.61	8	SPRINT NEXTEL CORPORATION	OVERLAND PARK	
P	0000256	270.00	8	JAMES E. NASH	SOUTH MILLS	1097 343 HWY N
P	0001703	270.00	1	VAN ZANDER	MOYOCK	812 TULLS CREEK RD
P	0001672	268.26	5	DAVE SILVA	CAMDEN	390 158 HWY
P	0000295	265.98	2	HENDERSON AUDIOMETRICS, INC.	CAMDEN	330 158 HWY E
P	0001693	261.90	6	ALLIANCE NISSAN	CAMDEN	158 HWY W
P	0002194	251.03	1	MORGAN ROBERSON	SHILOH	849 SANDY HOOK RD S
P	0001250	247.91	5	MICHELE LEE TAYLOR	SOUTH MILLS	108 BINGHAM RD
P	0001010	243.13	2	RAYBURN BURGESS	SHILOH	116 EDGEWATER DR
P	0001106	239.24	8	JAMI ELIZABETH VANHORN	SOUTH MILLS	617 MAIN ST
P	0001952	238.91	3	SANDY BOTTOM MATERIALS, INC	SOUTH MILLS	319 PONDEROSA RD

08/03/15 08:58:29

Delinquencies Top-30 Unpaid

Attachment "A"
Personal

Roll	Parcel Number	YrsDlq	Unpaid Amount	Taxpayer Name	City	Property Address
P	0001046	10	1,110.60	THIEN VAN NGUYEN	SHILOH	133 EDGEWATER DR
P	0000738	10	1,092.13	LESLIE ETHERIDGE JR	CAMDEN	
P	0001072	10	778.93	PAM BUNDY	SHILOH	105 AARON DR
P	0000248	10	326.53	ROBERT H. OWENS	CAMDEN	363 # 15
P	0000956	10	314.49	HUNG PHI LE	SHILOH	103 EDGEWATER DR
P	0001220	10	219.05	KIMBERLY DIANE JOHNSON	SOUTH MILLS	172 KEETER BARN RD
P	0000837	10	139.42	DUC MINH LE		
P	0000316	10	122.12	JAMES P. JONES	CAMDEN	142 SANDHILLS RD
P	0000352	9	443.65	ROBERT F. NERNEY	ELIZABETH CITY	107 SMALL DRIVE
P	0001227	9	322.05	THUAN NGOC TRAN	SHILOH	257 SAILBOAT RD
P	0001106	9	239.24	JAMI ELIZABETH VANHORN	SOUTH MILLS	617 MAIN ST
P	0000010	8	278.61	SPRINT NEXTEL CORPORATION	OVERLAND PARK	
P	0000256	8	270.00	JAMES E. NASH	SOUTH MILLS	1097 343 HWY N
P	0001538	7	798.61	JEFFREY EDWIN DAVIS	HERTFORD	MIC MAC TRAIL
P	0001545	7	160.66	LOUIS RUGGERI	ELIZABETH CITY	CAMDEN CAUSEWAY
P	0001540	7	120.95	DAVID LUKE	ELIZABETH CITY	CAMDEN CAUSEWAY
P	0001709	6	1,531.32	JOHN MATTHEW CARTE	CAMDEN	158 HWY
P	0001672	6	268.26	DAVE SILVA	CAMDEN	158 HWY
P	0001693	6	261.90	ALLIANCE NISSAN	CAMDEN	158 HWY W
P	0001673	6	177.05	THOMAS PHILLIP WINSLOW	CAMDEN	158 HWY W
P	0001827	5	652.02	KAREN BUNDY	CAMDEN	431 158 US W
P	0001250	5	247.91	MICHELE LEE TAYLOR	SOUTH MILLS	108 BINGHAM RD
P	0002775	5	235.33	JEFFREY D & KIMBERLEE S KENNEY	SOUTH MILLS	164 MCPHERSON RD
P	0001910	5	155.91	JEFFREY GEGAN	CAMDEN	379 COUNTRY CLUB RD
P	0001883	4	655.29	DUNG LE TRAN	SHILOH	255 SAILBOAT ROAD
P	0001739	4	655.07	COAST TO COAST POWDER COATING	CAMDEN	330 158 HWY E
P	0001116	4	409.86	AL JORDAN	CAMDEN	390 158 HWY W
P	0001905	4	340.08	AAR CORPORATION ETAL	SOUTH MILLS	211 FLYING TIGER RD
P	0000421	4	227.73	CLARENCE MUNDEN	CAMDEN	
P	0002081	4	217.24	ROBERT VERNON BRAY	CAMDEN	120 LAUREN LANE

08/03/15 08:58:30

Delinquencies Top-30 Oldest

Attachment "B"
Personnel

**Camden County Board of Commissioners
AGENDA ITEM SUMMARY SHEET**

Item Number: 5.B

New Business

Meeting Date: September 8, 2015

Attachments: 2 (4 Pages)

Submitted By: Michael Renshaw, County Manager

**ITEM TITLE: Core Area Waste Water Treatment
Plant Proposal for Hydrogeologic and
Soils Analysis**

MOTION MADE BY:	
S. Duckwall	
G. Meiggs	
M. McLain	
C. Riggs	
T. White	
NO MOTION	
VOTE:	
S. Duckwall	
G. Meiggs	
M. McLain	
C. Riggs	
T. White	
ABSENT	
RECUSED	

SUMMARY:

Attached to this report is a proposal for a geohydrology and soils analysis evaluation submitted by Edwin Andrews and Associates, P.C. The purpose of this study is to determine the suitability of an approximately 27 acre tract of land (Williams Farms of North Carolina) for a future Core Area Waste Water Treatment Plant using high-rate infiltration (amphidrome) technology. The proposed site which will be evaluated is located approximately 1 mile east of the intersection of HWY 158 East and HWY 34, across from the Camden Business Park. The 27 acre tract of land would provide expandable future waste water treatment capacity to 120,000 GPD within the Core Service Area.

The attached proposal is divided into two phases. Phase 1 includes preliminary test borings and measurements of water infiltration rates on the site as well as twelve geotechnical borings to be performed by GET Solutions. These geotechnical borings will be used to configure the exact locations of the high infiltration sand basins using the best sand aquifer matrix possible. Phase 1 also includes soil analyses, test well construction, aquifer testing and construction of a steady-state computer model (using MODFLOW software) to evaluate alternative placements of the infiltration basins. The proposal anticipates completing Phase 1 testing and evaluations within 8 weeks of Notice to Proceed. The total proposed cost of Phase 1 testing is \$24,260 (\$16,000 of which is the geohydrologic and soils analysis and \$8,260 for GET Solutions to perform the necessary geotechnical borings).

Phase 2 testing under the attached proposal would be used to finalize all soil, argonomic, and hydrogeologic analyses needed for permitting of the WWTP at the state level. It was decided that only upon a favorable Phase 1 geohydrologic report would the county proceed with funding for Phase 2 testing in the proposed amount of \$19,780.

The Finance Officer has prepared Budget Amendment 2015-16-BA003 reflecting the transfer of \$25,000 of Capital Reserve Fund Balance to cover the cost of Phase 1 testing.

RECOMMENDATION:

The County Manager recommends that the Board of Commissioners approve funding for Phase 1 geohydrologic analyses and geotechnical borings at the described Williams Farms of North Carolina site in the amount of \$24,260 using Capital Reserve Fund Balance and authorize the Manager to execute the attached Phase 1 agreement.

EDWIN ANDREWS & ASSOCIATES, P.C.

CONSULTING HYDROGEOLOGY AND SOIL SCIENCE

P.O. BOX 30653
RALEIGH, N.C. 27622 - 0653
PHONE: (919) 851 - 7844
FAX: (919) 851 - 6058

August 7, 2015

Mr. Michael Renshaw
County Manager
P.O. Box 190
Camden, N.C. 27921Re: Proposal Hydrogeologic and Soils Analysis; Williams Site
Camden, NC, EAA Prop INF 080715B

Dear Mr. Renshaw:

This proposal offers hydrogeologic and soil evaluation of the William's Tract, which is located approximately 1 mile east of the intersection of Rt 34 and US 58 Camden, N.C. This evaluation is to determine suitability of the site for wastewater disposal using infiltration basins. The proposal is divided into two phases. Phase I, is similar in scope to the investigation for the site off of Rt 343, that we completed in June 2015, except that there will be geotechnical borings and survey support at the Williams Tract. Phase II is to further evaluate the hydrogeology and soils needed for permitting, in the event that Camden County, wishes to pursue obtaining a Non-Discharge Permit from N.C.D.W.R. Phase II provides cost estimates for the soils, agronomic and hydrogeologic analysis needed for permitting.

Phase I:

The first phase offers a preliminary analysis similar to the report we completed in June, with the addition of twelve geotechnical borings by GET. The geotechnical boring logs will be used to configure the basins using the best sand aquifer matrix feasible, taking into account potential setbacks. With this mapping to locate a test well site, we will construct the aquifer test wells, perform the aquifer test, so that we can build the preliminary models.

This phase includes soil analysis, test well construction, aquifer testing and construction of a steady state computer model (MODFLOW) so that we can evaluate alternatives.

Phase II

The second phase would be to complete all Soil, Agronomic and Hydrogeologic Analyses needed for permitting: This proposed evaluation will be to continue to analyze the site for high rate infiltration using basins to conform with 15A NCAC 2T .0706(a or b) and requirements in the associated policy documents. This analysis will also conform with with the rules change from 15A NCAC 2H .0200 to 15ACNC 2T .0700 (2006) and subsequent policies pertaining to soils, and hydrogeologic analysis.

The following policies need to be included in the site evaluation protocol:
 May 31, 2007, "Hydrogeologic Investigation and Reporting Policy"
 May 31, 2007, "Groundwater Modeling Policy"
 September 12, 2008, "Soil Scientist Evaluation Policy"
 September 12, 2008, " Water Balance Calculation Policy"

SCHEDULE

We propose to complete the Phase I evaluation within eight weeks of receiving notice to proceed. However, delays may be possible depending on the time to receive the results of the survey support and drawings.

Fees:

Phase I: - Preliminary Analysis of Design Alternatives:

Construct piezometers (12) - Map water table surface	\$ 1,800.00
Survey support (estimate)	\$ 1,000.00
Soils Analysis - evaluate geotechnical borings and map aquifer	\$ 2,800.00
Construct two wells for aquifer testing	\$ 2,500.00
Perform aquifer testing and analysis	\$ 2,800.00
Build and Refine Calibration Model	\$ 2,500.00
Analyze Options using Steady State Loading Model - Letter Report	<u>\$ 2,600.00</u>
	Subtotal: \$16,000.00
Geotechnical Borings and services GET	<u>\$8,260.00</u>
	Total Phase I - \$24,260.00

Phase II: - Additional efforts to finalize support for NC DWR Permit Application Support:

Perform Water Balance - Hydraulic Conductivity Analyses	\$2,800.00
Perform Sensitivity Analysis	\$2,380.00
Loading Model Analysis	\$6,160.00
Solute Transport Modeling	\$5,800.00
Report	<u>\$2,640.00</u>
	Total Phase II - \$19,780.00

Total through permitting \$44,040.00

I have attached a proposal acceptance form for Phase I, if you wish to use it, or a simple purchase order could be used, when you are ready. I look forward to working with Camden County.

Very truly yours,
 Edwin Andrews & Associates, P.C.



Edwin E. Andrews III, P.G., N.C.L.S.S.
 Consulting Hydrogeologist and Soil Scientist

encl.

Mr. Michael Renshaw
County Manager, Camden County, N.C.
Re: Proposal Hydrogeologic and Soils Analysis;
Camden County, NC, EAA Prop INF 0807151B
August 7, 2015

HYDROGEOLOGY
GEOLOGY

ENVIRONMENTAL SCIENCES
SOILS

EDWIN ANDREWS & ASSOCIATES, P.C.

CONSULTING HYDROGEOLOGY AND SOIL SCIENCE

P.O. BOX 30653
RALEIGH, N.C. 27622 - 0653
PHONE: (919) 851 - 7844
FAX: (919) 851 - 6058

LETTER OF AGREEMENT ACCEPTED - Phase 1:

We (I) the undersigned having authority to execute this Agreement for the Owner and having read and understood the proposal for Camden County, Williams Tract Camden, N.C., dated August 7, 2015 (identified as Proposal number PINF 0807151B Preliminary Analysis Phase I site - \$16,000.00 each plus \$8,260.00 Geotechnical Drilling - \$24,260.00 Total; do hereby agree to the terms and conditions stated therein and referenced documents or attachments as evidenced by my seal.

Name & Address of Owner _____

Signature Preliminary: _____

Signature Preliminary+ Complete Analysis: _____

Name & Title (Printed): _____

Date: _____

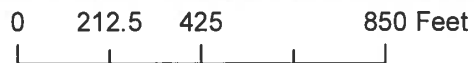
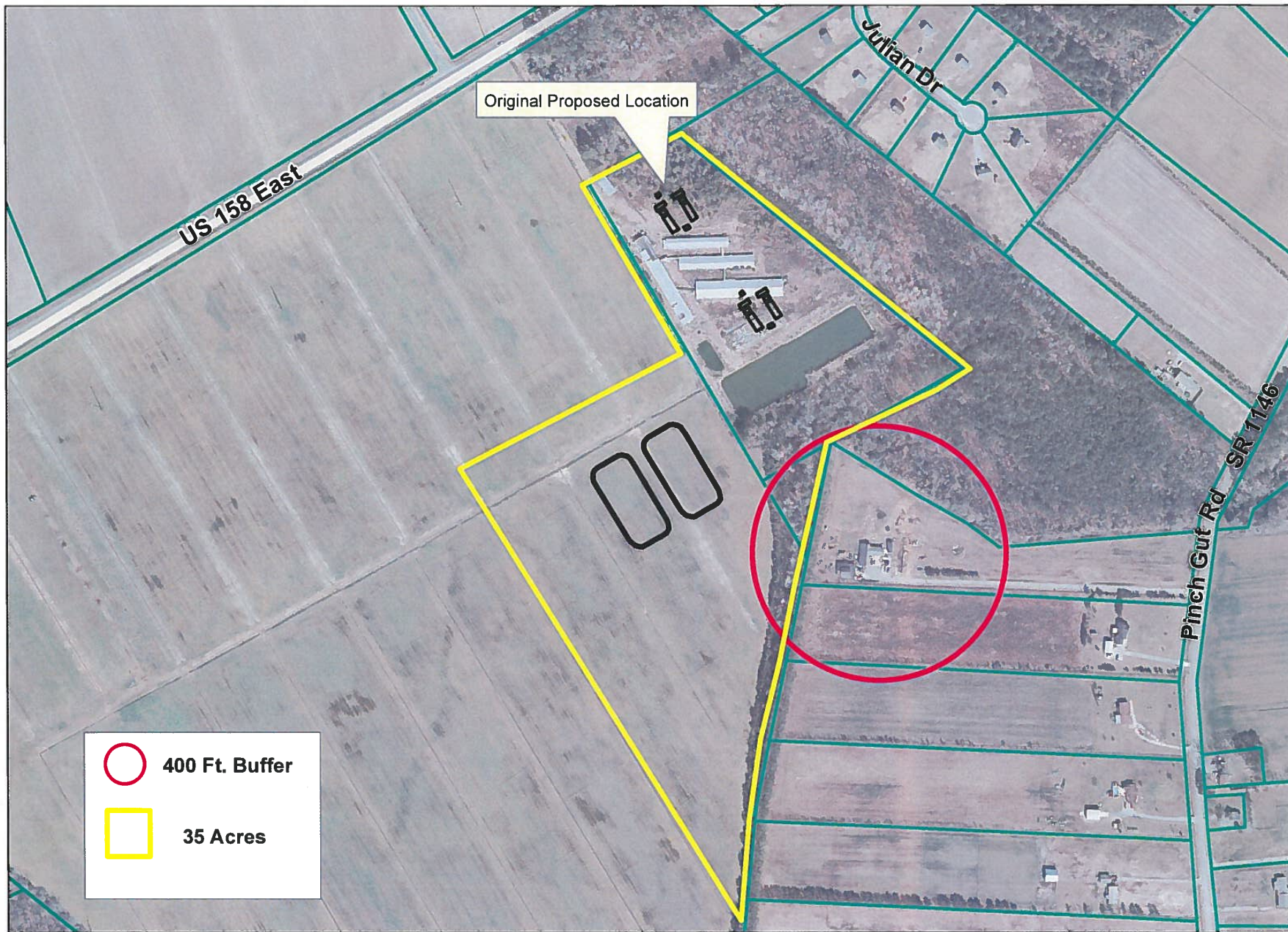

**Camden County Board of Commissioners
AGENDA ITEM SUMMARY SHEET**

Item Number: 5.C

New Business

Meeting Date: September 8, 2015
Attachments: 3 (10 Pages)
Submitted By: Michael Renshaw, County Manager

ITEM TITLE: **Darkness to Light: Child Sexual Abuse Awareness and Prevention Training Program**

MOTION MADE BY:	
S. Duckwall	
G. Meiggs	
M. McLain	
C. Riggs	
T. White	
NO MOTION	
VOTE:	
S. Duckwall	
G. Meiggs	
M. McLain	
C. Riggs	
T. White	
ABSENT	
RECUSED	

SUMMARY:

On August 31st the County Manager, Camden County Public Schools (CCPS) Superintendent, and Camden County Sheriff had an opportunity to attend a presentation by Ed and Patricia Boelte concerning a child sexual abuse awareness and prevention training program which they facilitate. The program, known as Stewards of Children by Darkness to Light, is a 2-hour course approved for Continuing Education Credits by the National Association of Social Workers and the National Board of Certified Counselors. A summary of the Darkness to Light: Stewards of Children 5 Steps to Protecting Our Children program is included in this packet.

While it is an uncomfortable topic for discussion, child sexual abuse is an enormously important social malady that can only be addressed by shining light on the issue and increasing public awareness. No community is immune from the financial and human costs associated with this epidemic. In the United States more than 400,000 children are sexually abused each year...1 in 10 children face the horror of sexual abuse. Ninety percent of victims are abused by someone they know and trust, 60% of abusers are acquaintances and 30% are immediate or extended family members. Only through increasing public awareness and training can we begin to eradicate child sexual abuse in our community.

Mr. and Mrs. Boelte have approached Camden County with an offer to facilitate the Stewards of Children: 5 Steps to Protecting Our Children course to members of the Camden County Sheriff's Office, Department of Social Services, and teachers and staff of Camden County Public Schools on Friday, October 2nd.

While the Boelte's charge no fees for facilitating this course, a nominal charge of \$10 per participant is requested to cover the cost of the course workbooks and handouts. The Camden County Sheriff, Director of Social Services, and CCPS Superintendent have expressed a desire to have select members of their staff participate in this training. Camden County would cover the cost of county employees using existing training funds, and CCPS would cover the materials costs for their staff to attend. Superintendent Hawkins has agreed to provide an appropriately-sized school facility for the training session which will take place on a scheduled mandatory teacher workday.

In addition to the Friday October 2nd course offering, the Boelte's have also offered to facilitate a second 2-hour session on Saturday, October 3rd. It was discussed that a local church might be willing to host such a session which would be open to the general public at no charge except the \$10 fee to cover materials costs. The County Manager will outreach to the local churches to determine which might be available and willing to serve as a host facility.

RECOMMENDATION:

The County Manager recommends that the Board of Commissioners approve the above described Child Sexual Abuse Awareness and Prevention Program sponsored by Darkness to Light and facilitated by Ed and Patricia Boelte. The materials fees associated with county staff attendance will be covered using previously budgeted training funds (estimated to be \$200 based upon projected staff attendance).

In addition, the County Manager recommends that the Board of Commissioners approve funding in an amount not to exceed \$450 to be provided to the Boelte's to cover their travel, meal, and overnight lodging expenses.

D DARKNESS to LIGHT

ABOUT DARKNESS TO LIGHT

Darkness to Light (D2L) is a national nonprofit organization that provides individuals, organizations, and communities with the tools to protect children from sexual abuse. Using an evidence-informed platform, D2L programs teach adults to prevent, recognize, and react responsibly to child sexual abuse.



WHO WE SERVE

Children are the ultimate beneficiary of what we do. We seek to provide all children with the opportunity to grow up healthy and happy, with their sexual boundaries intact. In this endeavor, D2L enlists the support and assistance of concerned adults in communities across the nation and globe, including:

- Educators in public and private school settings
- Staff and volunteers in youth serving organizations
- Staff and infant/youth workers in faith centers
- Students enrolled in youth serving degree plans at higher learning institutions
- Parents and caregivers

WHAT WE DO

Darkness to Light offers a variety of child-protective programs, including:

- *5 Steps to Protecting Our Children™*, a blueprint for preventing child sexual abuse.
- *Stewards of Children®*, a prevention program for adults that increases knowledge, improves attitudes, and changes child-protective behaviors. This program is available online or through a facilitator-led session.
- *Partner in Prevention*, a designation available to organizations that implement child protective policies and provide Stewards of Children training to all volunteers and staff who work with children.
- *Prevent Now!*, a model of community engagement that provides the tools for building and sustaining community prevention efforts.
- 866-FOR-LIGHT, a help line supported by a network of trained information and referral systems throughout the country. This crisis line routes callers to a referral service in their community where they can get information and support services.

TRAINING

- Over 7,000 authorized program facilitators in all 50 states and 16 international locations - the largest network of child protection advocates worldwide.
- Over 900,000 adults trained to protect children, worldwide.
- Over 100,000 school personnel training in the state of Texas as part of a statewide initiative legislatively mandated, and guided by the Texas Education Agency.
- 600 Texas teachers trained on August 21, 2013, representing the largest single-day training of its kind.
- Nearly 40,000 teachers trained in cooperation with the South Carolina Department of Education — the first statewide educator-focused prevention program in the country.
- 799 teachers trained in Fayette County, Georgia, on May 28, 2014, setting a new single-day training record and becoming the first Metro Atlanta school system to train all staff in child sexual abuse prevention.
- Implementation in course curriculum at multiple colleges and universities throughout the United States, including a campus-wide training initiative for all staff, volunteers, and cadets at The Citadel in Charleston, South Carolina, and training initiatives at all Delaware universities.
- Training partnerships with over 250 YMCAs throughout the country, including statewide Y initiatives in New Jersey, Delaware, Massachusetts, and Rhode Island.
- Ongoing training of all New Jersey Department of Law and Public Safety employees, mandated by Acting Attorney General John J. Hoffman.
- Partnership with Association of Christian Schools International to provide training to member schools throughout the nation and globe.
- 11 active statewide Stewards of Children training initiatives.

RECOGNITION

- 2014 Telly Award for the Stewards of Children documentary video production.
- 2014 recognition by the United Nations Foundation as a worldwide Top 5 Child Rights program.
- 2013 Social Responsibility Champion Award from the New Jersey Alliance of YMCAs.
- 2013 designation as a model program by the U.S. Department of Justice Office of Juvenile Justice and Delinquency Prevention.
- 2013 Impact Grant from the Cornerstone OnDemand Foundation, enabling D2L to offer Stewards of Children through one of the most advanced online learning management systems available.
- 2007 Crime Prevention Program of the Year from the National Crime Prevention Council.

Join the movement to end child sexual abuse! Visit www.D2L.org/Join for more information.



/DarknesstoLight



@Darkness2Light



D2Lblog.com

LEARN THE FACTS about child sexual abuse

400,000 children
are sexually abused each year.



That means **1 in 10** children
faces the horror of sexual abuse.



90% of victims are abused by someone they
know and **trust**.

» **60%** are **acquaintances** like teachers,
neighbors, or community leaders.

» **30%** are immediate or extended **family**.

Only 10% are **strangers** to the child.

A reactive approach does not work.

Only 31% of children tell someone within the first year.

Only 55% of reported incidents are investigated by CPS.

Only 29% of reported incidents lead to police arrests.



Many sexually abused
children suffer **trauma**
severe enough to
negatively impact their
adult lives. They're **3x**
more likely to abuse
drugs or **alcohol**, and
2x more likely to
drop out of school.

**SOMETHING
MUST BE DONE**



DARKNESS to LIGHT
END CHILD SEXUAL ABUSE



THE 5 STEPS To Protecting Our Children™

1

Learn the Facts

1 in 10 children are sexually abused.
Over 90% of them know their abuser.

2

Minimize Opportunity

Eliminate or reduce isolated, one-on-one
situations to decrease risk for abuse.

3

Talk About It

Have open conversations with children
about our bodies, sex, and boundaries.

4

Recognize the Signs

Know the signs of abuse to protect
children from further harm.

5

React Responsibly

Understand how to respond to risky
behaviors and suspicions or reports of
sexual abuse.

©2013

Darkness to Light is a non-profit organization that
provides adults with the tools and training to prevent,
recognize, and react responsibly to child sexual abuse.
Scan the QR code to learn more about the 5 Steps.



**Camden County Board of Commissioners
AGENDA ITEM SUMMARY SHEET**

Item Number: 6.A

BOARD APPOINTMENTS

Meeting Date: September 8, 2015

Attachments: 1 (1 Pages)

Submitted By: Clerk to the Board

ITEM TITLE: Jury Commission

MOTION MADE BY:	
S. Duckwall	
G. Meiggs	
M. McLain	
C. Riggs	
T. White	
NO MOTION	
VOTE:	
S. Duckwall	
G. Meiggs	
M. McLain	
C. Riggs	
T. White	
ABSENT	
RECUSED	

SUMMARY:

Clerk of Superior Court, Paula J. Harrison, sent the attached letter requesting the Board of Commissioners appoint Gail R. Perry to serve on the Jury Commission.

RECOMMENDATION:

Appoint Gail R. Perry of Shiloh to serve on the Jury Commission



State of North Carolina
General Court of Justice
CLERK OF SUPERIOR COURT

CAMDEN COUNTY

P.O. BOX 219, 117 NC HWY 343 NORTH
CAMDEN, NC 27921
TELEPHONE: (252) 336-4000
FAX: (252) 336-4001

PAULA J. HARRISON, CLERK
EX OFFICIO JUDGE OF PROBATE

JERRY R. TILLET
RESIDENT JUDGE

August 18, 2015

Camden County Board of Commissioners
P.O. Box 190
Camden, NC 27921

Re: Jury Commission Appointee

Dear Commissioners:

It will soon be time for the jury commission to begin its work. This committee consists of three members: one selected by the Senior Resident Superior Court Judge, the second selected by the Clerk of Superior Court and the third person named by the Board of Commissioners. This task usually takes approximately half a day to complete and the members are paid minimum wage or at a rate approved by the commissioners.

I would ask that you consider appointing Gail R. Perry of Shiloh as the Board's candidate for this position. As Mrs. Perry is a retired school teacher, I am sure she will be a fine addition to the jury commission.

Thank you for your consideration in this matter.

Respectfully,

A handwritten signature in blue ink that reads "Paula".

Paula J. Harrison
Clerk of Superior Court

**Camden County Board of Commissioners
AGENDA ITEM SUMMARY SHEET**

Item Number: 7.A

CONSENT AGENDA

Meeting Date: September 8th, 2015

Attachments: 6

Submitted By: Clerk to the Board

ITEM TITLE: Draft Meeting Minutes

MOTION MADE BY:	
S. Duckwall	
G. Meiggs	
M. McLain	
C. Riggs	
T. White	
NO MOTION	
VOTE:	
S. Duckwall	
G. Meiggs	
M. McLain	
C. Riggs	
T. White	
ABSENT	
RECUSED	

SUMMARY:

- May 4th, 2015 - Regular Session**
- May 19th, 2015 - Budget Work Session**
- May 21st, 2015 - Budget Work Session**
- June 1st, 2015 - Regular Session**
- June 8th 2015 - Budget Hearing**
- June 15th, 2015 - Regular Session**

RECOMMENDATION:

For Review and Possible Approval

**Camden County Board of Commissioners
AGENDA ITEM SUMMARY SHEET**

Item Number: 7.B

Consent Agenda

Meeting Date: September 8, 2015

Attachments: 4

Submitted By: Budget & Finance Officers

ITEM TITLE: Budget Amendments

MOTION MADE BY:	
S. Duckwall	
G. Meiggs	
M. McLain	
C. Riggs	
T. White	
NO MOTION	
VOTE:	
S. Duckwall	
G. Meiggs	
M. McLain	
C. Riggs	
T. White	
ABSENT	
RECUSED	

SUMMARY:

Appropriate funds for Seymore Well Project (BA 002) and
Wastewater Treatment Plant (BA 003) Expenditures
Approve expenditures for Debris Removal (BA 004)
Approve expenditures and match for SM VFD state grant (BA 005)

RECOMMENDATION:

Approve Request

2015-16-BA002
CAMDEN COUNTY BUDGET AMENDMENT

BE IT ORDAINED by the Governing Board of the County of Camden, North Carolina that the following amendment be made to the annual budget ordinance for the fiscal year ending June 30, 2016.

Section 1. To amend the Water/Sewer Upgrade and Capital Fund as follows:

ACCT NUMBER	DESCRIPTION OF ACCT	AMOUNT	
		INCREASE	DECREASE
Revenues			
23399720-439900	Fund Balance Appropriated	\$140,000.00	
23330720-439710	County Contribution	\$345,000.00	
Expenses			
237200-567201	Raw Water Main	\$125,000.00	
237200-567202	Production Well	\$250,000.00	
237200-503200	Engineering Fees	\$ 35,000.00	
237200-545000	Contracted Services	\$ 35,000.00	
237200-500000	Contingency	\$ 40,000.00	
Revenues			
71399660-439900	Fund Balance Appropriated	\$345,000.00	
Expenses			
716600-567203	Well Project	\$345,000.00	

This Budget Amendment is made to increase the budget for the Seymore Well project expenditures in current Fiscal Year.

This will result in a decrease of \$0 in the Contingency of the General Fund.
Balance in Contingency \$40,000.00

Section 2. Copies of this budget amendment shall be furnished to the Clerk to the Governing Board and to the Budget Officer and the Finance Officer for their direction. Adopted this 8th day of September, 2015.

Clerk to Board of Commissioners

Chairman, Board of Commissioners

2015-16-BA003
CAMDEN COUNTY BUDGET AMENDMENT

BE IT ORDAINED by the Governing Board of the County of Camden, North Carolina that the following amendment be made to the annual budget ordinance for the fiscal year ending June 30, 2016.

Section 1. To amend the General Fund and Capital Fund as follows:

ACCT NUMBER	DESCRIPTION OF ACCT	AMOUNT	
		INCREASE	DECREASE
Revenues			
106810-564202	Wastewater Treatment Plant	\$25,000.00	
Expenses			
10390400-439773	Capital Reserve Transfer	\$25,000.00	
Revenues			
71399660-439900	Fund Balance Appropriated	\$25,000.00	
Expenses			
716600-564202	Wastewater Treatment Plant	\$25,000.00	

This Budget Amendment is made to increase the budget for the Wastewater Treatment Plant project expenditures in current Fiscal Year.

This will result in a decrease of \$0 in the Contingency of the General Fund.
 Balance in Contingency \$40,000.00

Section 2. Copies of this budget amendment shall be furnished to the Clerk to the Governing Board and to the Budget Officer and the Finance Officer for their direction. Adopted this 8th day of September, 2015.

 Clerk to Board of Commissioners

 Chairman, Board of Commissioners

2015-16-BA004
CAMDEN COUNTY BUDGET AMENDMENT

BE IT ORDAINED by the Governing Board of the County of Camden, North Carolina that the following amendment be made to the annual budget ordinance for the fiscal year ending June 30, 2016.

Section 1. To amend the Watershed Funds as follows:

ACCT NUMBER	DESCRIPTION OF ACCT	AMOUNT	
		INCREASE	DECREASE
Revenues			
36399472-439900	Fund Balance Appropriated	\$2,351.00	
Expenses			
364720-545000	Contracted Services	\$2,351.00	
Expenses			
374720-545000	Contracted Services	\$11,760.00	
374720-599900	Fund Reserves		\$11,760.00

This Budget Amendment is made to increase the budget for the Watershed Fund expenditures in current Fiscal Year.

This will result in a decrease of \$0 in the Contingency of the General Fund.
 Balance in Contingency \$40,000.00

Section 2. Copies of this budget amendment shall be furnished to the Clerk to the Governing Board and to the Budget Officer and the Finance Officer for their direction. Adopted this 8th day of September, 2015.

 Clerk to Board of Commissioners

 Chairman, Board of Commissioners

2015-16-BA005
CAMDEN COUNTY BUDGET AMENDMENT

BE IT ORDAINED by the Governing Board of the County of Camden, North Carolina that the following amendment be made to the annual budget ordinance for the fiscal year ending June 30, 2016.

Section 1. To amend the South Mills VFD Fund as follows:

ACCT NUMBER	DESCRIPTION OF ACCT	AMOUNT	
		INCREASE	DECREASE
Revenues			
41360530-434815	State Grant	\$30,000.00	
41399530-439990	Fund Balance Appropriated	\$30,000.00	
Expenses			
415300-564108	NC Grant Equipment	\$60,000.00	

This Budget Amendment is made to increase the budget for the South Mills VFD Fund expenditures in current Fiscal Year.

This will result in a decrease of \$0 in the Contingency of the General Fund.
 Balance in Contingency \$40,000.00

Section 2. Copies of this budget amendment shall be furnished to the Clerk to the Governing Board and to the Budget Officer and the Finance Officer for their direction. Adopted this 8th day of September, 2015.

 Clerk to Board of Commissioners

 Chairman, Board of Commissioners

**Camden County Board of Commissioners
AGENDA ITEM SUMMARY SHEET**

Item Number: 7.C

Consent Agenda

Meeting Date: September 8, 2015
Attachments: 1
Submitted By: Budget & Finance Officers

ITEM TITLE: Expenditure Request

MOTION MADE BY:	
S. Duckwall	
G. Meiggs	
M. McLain	
C. Riggs	
T. White	
NO MOTION	
VOTE:	
S. Duckwall	
G. Meiggs	
M. McLain	
C. Riggs	
T. White	
ABSENT	
RECUSED	

SUMMARY:

The attached debris removal services were performed for the Shiloh, South Mills and Sawyer’s Creek Watershed. Each service exceeds the \$7,000 Budget Officer approval limit for payment per the 15-16 Budget Ordinance Article XXIV. Section 1(e).

RECOMMENDATION:

Approve request for payment

J & J Environmental, LLC

1815C Virginia Road
Edenton, NC 27932

Invoice

Date	Invoice #
8/26/2015	1535

Bill To
Camden SWCD Brian Lannon PO Box 190 117 NC Hwy 343 N Camden, NC 27921
<i>Shiloh Watershed</i>

P.O. No.	Terms	Project

Quantity	Description	Rate	Amount
26	Dailey Road Stream Debris Removal	294.00	7,644.00
Total			7,644.00

J & J Environmental, LLC

1815C Virginia Road
Edenton, NC 27932

Invoice

Date	Invoice #
8/26/2015	1534

Bill To
Camden SWCD Brian Lannon PO Box 190 117 NC Hwy 343 N Camden, NC 27921
<i>Shiloh Watershed</i>

P.O. No.	Terms	Project

Quantity	Description	Rate	Amount
27	Stream debris removal on Trotman Road	294.00	7,938.00
Total			57,938.00

J & J Environmental, LLC

1815C Virginia Road
Edenton, NC 27932

Invoice

Date	Invoice #
8/26/2015	1536

Bill To
Camden SWCD <i>South Mills Watershed</i> Brian Lannon PO Box 190 117 NC Hwy 343 N Camden, NC 27921

P.O. No.	Terms	Project

Quantity	Description	Rate	Amount
29	South Mills Elm Street Ditch #1 Stream Debris Removal	294.00	8,526.00
		Total	\$8,526.00

J & J Environmental, LLC

1815C Virginia Road
Edenton, NC 27932

Invoice

Date	Invoice #
8/26/2015	1533

Bill To
Camden SWCD <i>Sawyers Creek Watershed</i> Brian Lannon PO Box 190 117 NC Hwy 343 N Camden, NC 27921

P.O. No.	Terms	Project

Quantity	Description	Rate	Amount
40	Stream Debris Removal on Seymour Drive	294.00	11,760.00

Thank you for your business.	Total	\$11,760.00
------------------------------	--------------	-------------

**Camden County Board of Commissioners
AGENDA ITEM SUMMARY SHEET**

Item Number: 7.D

Consent Agenda

**Meeting Date: September 8,
2015 Attachments: 1
Submitted By: Tax Office**

ITEM TITLE: Tax Collection Report

MOTION MADE BY:	
S. Duckwall	
G. Meiggs	
M. McLain	
C. Riggs	
T. White	
NO MOTION	
VOTE:	
S. Duckwall	
G. Meiggs	
M. McLain	
C. Riggs	
T. White	
ABSENT	
RECUSED	

SUMMARY:

Tax Collection Report

RECOMMENDATION:

Review & Approve

**Camden County Board of Commissioners
AGENDA ITEM SUMMARY SHEET**

Item Number: 7.D

Consent Agenda

**Meeting Date: September 8,
2015 Attachments: 1
Submitted By: Tax Office**

ITEM TITLE: Tax Collection Report

MOTION MADE BY:	
S. Duckwall	
G. Meiggs	
M. McLain	
C. Riggs	
T. White	
NO MOTION	
VOTE:	
S. Duckwall	
G. Meiggs	
M. McLain	
C. Riggs	
T. White	
ABSENT	
RECUSED	

SUMMARY:

Tax Collection Report

RECOMMENDATION:

Review & Approve

REFUNDS OVER \$100.00

North Carolina Vehicle Tax System																	
NCVTS Pending Refund report																	
REFUNDS OVER \$100.00																	
Payee Name	Address 1	Address 2	Address 3	Refund Type	Bill #	Plate Number	Status	Transaction #	Refund Description	Refund Reason	Create Date	Authorization Date	Tax Jurisdiction	Levy Type	Change	Interest Change	Total Change
HALLENBURG, SUSAN	45 BREAM OAK		TRENTON, SC 29847	Proration	0025225256	EC5160	AUTHORIZED	32728450	Refund Generated due to proration on Bill #0025225256-2014-2014-0000-00	Tag Surrender	07/31/2015	8/4/2015 12:47:31 PM	1843	Tax	(\$184.75)	\$0.00	(\$184.75)
													1	Tax	(\$3.13)	\$0.00	(\$3.13)
																Refund	\$187.88

Submitted by Lisa S. Anderson Date 8-5-15
 Lisa S. Anderson, Tax Administrator Camden County

Approved by _____ Date _____
 P. Michael McLain, Chairman Camden County Board of Commissioners

TC906E 20 T15 ACS Tax System
 Bill No. Parcel No.
 R 83496 R 02-8945-00-91-7911.0000
 2014

Collections Inquiry
 Name Transaction Info
 ROBERT FRANCIS JAMES III P

* * * GROSS TAX REVERSAL * * *

Reason	9	MORT. REFUND REQUEST	COUNTY	1,326.56-
Receipt		262023	COURTHOUSE FIRE	22.49-
Trans#		219218	SF 30	10.86-
Posted as of		04/14/2015	** TOTAL BILL	1,359.91-
Cash Drawer	1	04/14/2015	INTEREST CITY	
			COUNTY	57.80-
Payee Name		GREEN TREE SVCG, LLC-	*INTEREST TOTAL*	57.80-
			**** TOTAL ****	1,417.71-
Posted on		06/30/2015 112424		
Posted By		TERI Terminal WO T		
Check Number		230072320		
Bank Name		WELLS FARGO BANK, N.A.		

*Mortgage Company requested a refund for the payment made on an accounty that has a payment agreement. Action? ..

Refund is to be sent to: Green Tree
 c/o CoreLogic
 1 CoreLogic Drive
 Westlake, TX 76262

Submitted by Lisa S. Anderson Date 8-24-15
 Lisa S. Anderson, Tax Administrator Camden County

Approved by _____ Date _____
 P. Michael McLain, Chairman Camden County Board of Commissioners



FROM: CAMDEN COUNTY ADMINISTRATOR OFFICE

Nº 17890

(1) REQUEST THE FOLLOWING CHANGES BE MADE

(2) EXPLANATION: () OVERCHARGED () DOUBLE LISTING
 () LATE LISTING () OTHER Military

YEAR 2015 TOWNSHIP CH

NAME Thomas Myers (16028178)

ADDRESS 305 Whitehall Rd.
Camden, NC 27921

PIN # 0027726549

RELEASE

<u>PROPERTY VALUE</u>	<u>COUNTY</u>	<u>FIRE</u>	<u>INTEREST</u>	<u>TOTAL</u>	<u>BILL #</u>
Personal _____					
Real _____					
Total _____					

PICK UP

<u>PROPERTY VALUE</u>	<u>COUNTY</u>	<u>FIRE</u>	<u>INTEREST</u>	<u>TOTAL</u>	<u>BILL #</u>
Personal _____					
Real _____					
Total _____					

ADJUSTMENT/REFUND

<u>PROPERTY VALUE</u>	<u>COUNTY</u>	<u>FIRE</u>	<u>INTEREST</u>	<u>TOTAL</u>	<u>BILL #</u>
Personal _____					
Real _____					
Total _____	<u>105.60</u>	<u>1.55</u>		<u>107.15</u>	<u>22726549</u>

Levi Smith
 TAX ADMINISTRATOR / Specialist

APPROVED _____ DAY OF _____ 20____

CHAIRMAN OF COMMISSIONERS COUNTY MANAGER

REFUNDS OVER \$100.00

 North Carolina Vehicle Tax System																	
NCVTS Pending Refund report																	
August Refunds																	
Payee Name	Address 1	Address 2	Address 3	Refund Type	Bill #	Plate Number	Status	Transaction #	Refund Description	Refund Reason	Create Date	Authorization Date	Tax Jurisdiction	Levy Type	Change	Interest Change	Total Change
MYERS, THOMAS	305 WHITEHALL RD		CAMDEN, NC 27921	Adjustment >= \$100	0027726549	DHN4233	AUTHORIZED	33779940	Refund Generated due to adjustment on Bill #0027726549-2015-2015-0000-00	Military	08/19/2015	8/20/2015 8:12:33 AM	1843	Tax	(\$105.60)	\$0.00	(\$105.60)
													2	Tax	(\$1.55)	\$0.00	(\$1.55)
															Refund	\$107.15	

Submitted By *Lisa S. Anderson* Date *9-1-15*
 Lisa S. Anderson, Tax Administrator Camden County

Approved By _____ Date _____
 P. Michael McLain, Chairman Camden County Board of Commissioners

**Camden County Board of Commissioners
AGENDA ITEM SUMMARY SHEET**

Item Number: 7.F

Consent Agenda

Meeting Date: September 8th, 2015
Attachments: 1
Submitted By: Tax Office

ITEM TITLE: Authorization to Collect

MOTION MADE BY:	
S. Duckwall	
G. Meiggs	
M. McLain	
C. Riggs	
T. White	
NO MOTION	
VOTE:	
S. Duckwall	
G. Meiggs	
M. McLain	
C. Riggs	
T. White	
ABSENT	
RECUSED	

SUMMARY:

Authorization to Collect – October renewals

RECOMMENDATION:

Review & Approve

STATE OF NORTH CAROLINA

COUNTY OF CAMDEN

TO: The Tax Administrator of Camden County October Ren. Due 11/15/15 (NEW SYSTEM)

You are hereby authorized, empowered, and commanded to collect the taxes set forth in the tax records filed in the office of the Tax Administrator and in the tax receipts herewith delivered to you, in the amounts and from the taxpayers likewise therein set forth. Such taxes are hereby declared to be a first lien upon personal property of the respective taxpayers in the County of Camden, and this order shall be a full and sufficient authority to direct, require, and enable you to levy on and sell personal property of such taxpayers for and on account thereof, in accordance with the law.

SOUTH MILLS	COURTHOUSE	SHILOH	TOTAL
17,577.83	17,665.99	9,310.01	44,553.83

Witness my hand and official seal this _____ day of _____

Chairman, Camden County Board of Commissioners

Attest:

Clerk to the Board of Commissioners of Camden County

This is to certify that I have received the tax receipts and duplicates for collection in the amounts as listed herein.

Lisa S. Anderson

Tax Administrator of Camden County

**Camden County Board of Commissioners
AGENDA ITEM SUMMARY SHEET**

Item Number: 7.G

Consent Agenda

Meeting Date: September 8th, 2015
Attachments: 2
Submitted By: Admin

ITEM TITLE: Constitution Week

MOTION MADE BY:	
S. Duckwall	
G. Meiggs	
M. McLain	
C. Riggs	
T. White	
NO MOTION	
VOTE:	
S. Duckwall	
G. Meiggs	
M. McLain	
C. Riggs	
T. White	
ABSENT	
RECUSED	

SUMMARY:

Staff received the attached proclamation request.

RECOMMENDATION:

Review & Approve



National Society Daughters of the American Revolution
Betsy Dowdy Chapter, 3-012-NC
Elizabeth City, North Carolina

Mr. Michael Renshaw
P O Box 190
Camden, NC 27921

August 12, 2015

Dear Mr. Renshaw

The Betsy Dowdy Chapter NSDAR respectfully requests that you present this proclamation at your first meeting in September 2015

After signature and presentation, we respectfully request that you return it in the self-addressed stamped envelope

If you have any questions, please feel free to contact me.

Sincerely

Cora deShong Wade, Regent
Betsy Dowdy Chapter NSDAR
cdwade3@gmail.com
(252) 435-6477

Proclamation
Constitution Week
September 17-23, 2015

WHEREAS, September 17, 2015 marks the two-hundred twenty-eighth anniversary of the drafting of the Constitution of the United States of America by the Constitution Convention; and

WHEREAS, it is fitting and proper to accord official recognition to this magnificent document and its memorable anniversary, and to the patriotic celebrations which will commemorate the occasion; and

WHEREAS, Public Law 915 guarantees the issuing of a proclamation each year by the President of the United States of America designating September 17th through 23rd as Constitution Week,

NOW, THEREFORE, BE IT PROCLAIMED, that we, the Camden County Board of Commissioners, NC do hereby ask all citizens to reaffirm the ideals the Framers of the Constitution had in 1787 by vigilantly protecting the freedoms guaranteed to us through this guardian of liberties, remembering that lost rights may never be regained.

IN WITNESS WHEREOF, I have set my hand and affixed the Great Seal of the County of Camden, NC.

P. Michael McLain
Chairman

**Camden County Board of Commissioners
AGENDA ITEM SUMMARY SHEET**

MOTION MADE BY:	
M. McLain	_____
S. Duckwall	_____
G. Meiggs	_____
T. White	_____
C. Riggs	_____
NO MOTION	_____
VOTE:	
M. McLain	_____
S. Duckwall	_____
G. Meiggs	_____
T. White	_____
C. Riggs	_____
ABSENT	_____
RECUSED	_____

Item Number: 7.H

Meeting Date: September 8, 2015

Attachments: Ordinance 2015-08-01, letters from Sheriff and County Attorney

Submitted By: Planning Department

ITEM TITLE: Set Public Hearing: Ordinance No. 2015-08-01 - Proposed amendments to Chapter 151 (Unified Development Ordinance) of the Camden County Code Ordinances

SUMMARY:

Proposed amendment to Table of Permissible Uses (Article 151.334), permitting Private Outdoor Firing Range for Law Enforcement Only (Use # 6.310) with the approval of a Special Use Permit. Range will be subject to the Specific Standards set out in Article 151.347 (S) of the UDO (attached) and any conditions applied to the Special Use Permit.

Planning Board met on August 19, 2015 and after presentation from Sheriff Perry, Planning Staff and discussion with Planning Board, Ordinance 2015-08-01 was recommended for approval on a 7-0 vote.

RECOMMENDATION:

Set Public Hearing for September 21, 2015

Ordinance No. 2015-08-01

**An Ordinance
Amending the Camden County
Code of Ordinances**

Camden County, North Carolina

BE IT ORDAINED BY THE CAMDEN COUNTY BOARD OF COMMISSIONERS as follows:

Article I: Purpose

The purpose of this Ordinance is to amend Chapter 151 of the Camden County Code of Ordinances of Camden County, North Carolina, which was originally adopted by the County Commissioners on December 15, 1997, and subsequently amended and as otherwise incorporated into the Camden County Code.

Article II. Construction

For purposes of this Ordinance, underlined words (underline) shall be considered as additions to existing Ordinance language and strikethrough words (~~strikethrough~~) shall be considered deletions to existing language. New language of proposed ordinance shall be shown in italics (*italics*) and underlined.

Article III. Amend Chapter 151 as amended of the Camden County Code which shall read as follows:

CHAPTER 151: UNIFIED DEVELOPMENT

§ 151.334 TABLE OF PERMISSIBLE USES.

USE#	DESCRIPTION	R-1	R-2	R-3	CCD	NCD	HC	MC	GUD	I-1	I-2
<i>6.310</i>	<i>Private Outdoor Firing Range – Law Enforcemenet Only Subject to §151.347(S)</i>								<u>S</u>	<u>S</u>	<u>S</u>

Adopted by the Board of Commissioners for the County of Camden this day of September, 2015.

County of Camden

P. Michael McLain, Chairman
Board of Commissioners

ATTEST:

Angie Wooten
Clerk to the Board

CAMDEN COUNTY SHERIFF'S OFFICE

Page 1 of 3

Post Office Box 57

Camden, North Carolina 27921

Tony E. Perry, Sheriff



Voice: 252-338-5046
Fax: 252-335-4300
24 Hours: 252-331-7445

MEMORANDUM

TO: Camden County Board of Commissioners

FROM: Sheriff Tony Perry

DATE: July 27, 2015

RE: Firing Range Need

The Camden County Sheriff's Office is mandated by the North Carolina Sheriff's Education and Training Standards Commission to qualify annually in firearms that deputies carry. Qualification ranges require maximum 25 yards on handguns, 40 yards on shotguns and 100 yards on rifles. Qualification times vary depending upon weather and availability of deputies to gather for a period over a week for classroom, day and night training. Furthermore, we may train with other agencies on site for qualification purposes.

For the last 13 years, George Wood Farms has allowed the Sheriff's Office through the Pasquotank County Sheriff's Office and then in 2008 through a County of Camden lease an area here in Camden for a firing range equipped with a berm and target area. In December 2014, that lease agreement was terminated by George Wood Farms due to the sale of farmland. I was contacted by Matt Wood in June 2015 that he was going to completely close the area and have it cleaned up.

I spoke with Currituck Sheriff in the use of their range for this year but after all the winter storms and rains, berms were washed away. I also met with Academi and they know by their Special Use Permit, they can allow the Sheriff's Office to use their range. I have requested further meetings with superiors at Academi, requested potential trainings available, and available range dates but have received no responses. Furthermore, we would not be a paying customer and if we planned to use the range, we could be bumped for a paying customer.

I met with Mike Renshaw back in January 2015 on the need for a firing range. John Morrison was informed of the termination of the George Wood Farm lease and the need to build a new range. For the last year, I have been looking for property in the county to build a new firing range. I had been in touch with one property owner in South Mills I thought had property available but was later discovered it was not. I have been reviewing

"Working Together For a Safer Tomorrow"

county owned property through GIS but was unable to find suitable property with a large area and a buffer zone.

Commissioner Michael McLain stated to me back in the spring of 2015 he had property that was possibly suitable for a firing range. I reviewed the GIS map for the McLain property and set up meetings with the County Planning Office -- Dave Parks and then with the Army Corps of Engineers (ACOE). The ACOE requested that a small area be cleared so that they could better determine wetlands possibilities.

I flew by airplane over the property during mid-June and saw that trees were growing in the proposed area. Through speaking with a former logger of the property they stated that there would be stumps from passed logging that would be six inches high that would create extra problems for clearing the area. Commissioner McLain said I could look at other areas of his property in which I did and discovered that where the logging operation stripped and loaded the logs was actually an area that would be easily cleared and cleaned. I have been to this area and bulldozed an area 100 feet by 150 feet pushing the dead logs and trees limbs to the side for the ACOE to make a determination on this area.

While this opportunity has risen with the McLain property, Law Enforcement Support Services (LESO) of the North Carolina Department of Public Safety just opened up for law enforcement to get equipment. LESO works in conjunction with the (military) Defense Logistics Agency that facilitates a law enforcement support program, which originated from the National Defense Authorization Act of Fiscal Year 1997 (FY 97). This law allows transfer of excess Department of Defense property that might otherwise be destroyed to law enforcement agencies across the United States and its territories.

No equipment is purchased for distribution. All items were excess which had been turned in by military units or had been held as part of reserve stocks until no longer needed. Since its inception, the program has transferred more than \$5.4 billion worth of property. In 2014, \$980 million worth of property (based on initial acquisition cost) was transferred to law enforcement agencies. Requisitions cover the gamut of items used by America's military -- clothing and office supplies, tools and rescue equipment, vehicles, rifles and others small arms. Of all the excess equipment provided through the program, only five percent are weapons and less than one percent is tactical vehicles. More than 8,000 law enforcement agencies have enrolled in the program.

Such equipment available that could be used to build a firing range was a bulldozer, a motor grader, a dump truck and a used pickup truck. We are currently looking for a front end loader. This equipment was given to the Sheriff's Office at no cost with the only stipulation that we hold it for 12 months then we could surplus and sell it.

At this point and the date of this memorandum, we are waiting for the ACOE to return sometime the second week of August to determine if the proposed area on the McLain property will be suitable for the range. After that, further consultation with the County Planning Office will be needed to start the process for permits. The UDO currently designates for commercial and private use firing ranges. This will not be for commercial

use and a designation of private use needs to be reviewed.

At the same time, a lease agreement will need approval between County of Camden and Michael McLain if the UDO will allow the range. Furthermore, the determined amount of leasing the property will be \$1.00 annually from the Sheriff's Office to McLain.

I have been working on this project to save the county a maximum amount of costs using available resources. I will be available for questions.

The Twiford Law Firm, P.C.

Russell E. Twiford (Retired)
John S. Morrison
Edward A. O'Neal
H.P. Williams, Jr.
R. Mark Warren
Courtney S. Hull
Lauren Arizaga-Womble
Megan Morgan

Attorneys At Law

P.O. Box 669
111 Currituck Commercial Drive
Moyock, North Carolina 27958-0669
Telephone (252) 435-2811
Telecopier (252) 435-9974

Elizabeth City Office
203 North Road Street
Elizabeth City, NC 27907-0099
Telephone (252) 338-4151
Telecopier (252) 338-8546

LOOK AT OUR WEBSITE:
www.twifordlaw.com

Please Respond To:
Moyock

July 27, 2015

Michael McLain
Michael Renshaw
Sheriff Perry
Via Email

Re: *Proposed Firing Range - McLain Lease*

Dear Gentlemen:

I reviewed Sheriff Perry's email of July 22, 2015, together with the agenda item summary sheet and proposed lease for a firing range. I have the following comments:

- Consideration - North Carolina law strictly prohibits any elected official from dealing with the government he serves in private transactions for valuable consideration. Indeed, it is a crime, and in certain cases, can be a felony. My review of the proposed lease, which as Sheriff Perry says "mirrored" that of what Matt Wood provided, is legally compliant in that Commissioner McLain is receiving only a token \$1.00 amount. Further, Commissioner McLain shall continue to be responsible for ad valorem property tax. Only personal property brought onto and stored on the property by the Sheriff would be subject to taxation. This seems highly unlikely to me. However, I caution both parties to carefully reflect upon this transaction. Is Commissioner McLain, in any way, receiving any valuable consideration? It certainly does not appear so. To the contrary, this appears more like a donation to the county. Nevertheless, given the severity of a legal violation here, everyone should carefully reflect upon this. To this end I suggest language be stricken from Article 2 that Lessor would have the right to terminate the lease if the rent payment goes unpaid for 15 days. That is the language of a commercial transaction rather than a gift. Even though the rent only \$1.00, I think it best not to in anyway imply this is a lease in which monetary rent is of prime importance.

• Transparency - As we all know, the Sheriff is a Constitutional officer and is not subject to regulation by the board of county commissioners except as to his budget. Nevertheless, conflicts can arise between the Sheriff's Dept. and the Board of Commissioners. Accordingly, this lease should be made to the public in open session. I do not see this rising to the level of a conflict of interest or even close to it; however, my perception may not be shared by others. If there is free and open disclosure that should go a long way towards removing any such concerns.

I have no opinion on the text amendment or the suitability of the subject property for a firing range. Otherwise, I have no legal issues.

If you have any questions, please contact me. I suggest all of this correspondence, including my position, be circulated to the full board prior to the next meeting.

Warmest Personal Regards,

John S. Morrison

John S. Morrison
Dictated but not reviewed
to expedite delivery

Camden County, NC Code of Ordinances

**TITLE XV: LAND USAGE / CHAPTER 151: UNIFIED DEVELOPMENT /
CONDITIONAL AND SPECIAL USES / § 151.347 SPECIFIC STANDARDS.**

* (S) The following minimum development standards shall apply to commercial shooting ranges which utilize firearms:

- (1) Use is only permitted with the issuance of a special use permit.
- (2) The use is allowed within the I-1 and I-2 districts with the issuance of a special use permit.
- (3) The design criteria cited in the Military Handbook - Range Facilities and Miscellaneous Training Facilities Other Than Buildings (MIL-HDBK-1027/3B), as amended or superseded or the National Rifle Association Range Manual, as amended or superseded shall be met. For those ranges constructed in accordance with the National Rifle Association Range Manual, the downrange safety area shall not apply, but the permit holder shall provide documentation of approval of the ranges by the NRA-sponsored team of inspectors annually.
- (4) The proposed shooting range shall be reviewed by and comments received from the County Sheriff's Department.
- (5) Hours of firing activities and number of ranges shall be set as conditions of the Special Use Permit.
- (6) Alcohol consumption shall be prohibited before and during range operations, but shall be allowed after the range is closed provided proper permits are obtained.
- (7) The adjacent areas to the proposed range shall be predominantly undeveloped.
- (8) All areas within the proposed range, including, but not limited to firing area(s), backstops, downrange safety zones, parking and accessory areas and the like shall be under uniform control or ownership. The downrange safety area shall be essentially fan-shaped, with its vertex being 100 meters each side of the end firing point and extending to the maximum range of the type of firearm being used as shown on Table 4 of the MIL-HDBK-1027/3B, ten degrees from the firing line, plus an additional 100 meters running parallel to the ten degree line, as shown in Figure 2.2-1 of MIL-HDBK-1027/3B or as approved in accordance with the NRA manual and inspections per division (S)(3) above. The safety area shall not encompass any public right-of-way or other property not owned by range operator or owner.
- (9) The operators of an outdoor range must provide proof of coverage by adequate accident and liability insurance. A minimum coverage of \$2,000,000 shall be established.
- (10) The site or area used as a shooting range shall be enclosed by a six-foot high fence or otherwise restricted by natural physical features (such as swamps, bodies of water,

Camden County, NC Code of Ordinances

and the like) so that access to the site is controlled to insure the safety of patrons, spectators and the public at large. Warning signs shall be posted along the fence every 100 feet.

(11) All shooting stations and backstops, when utilized, shall be at least 900 feet from any property line regardless of the direction of fire unless the applicant can provide noise or safety test evidence to show that a lesser distance may be acceptable.

(12) All parking areas, vehicle accommodation areas, driveways and the like shall meet standards for parking as stated in this chapter.

(13) Weapon types will be restricted to pistol, rifle and shotgun or similar unless authorized in accordance with division (S)(19) below. No automatic assault type weapon shall be used by the general public, but will be allowed by any law enforcement, military or federal agency group, or any holder of a Federal Firearms License of a class and type that authorizes NFA weapons, duly authorized to use these style weapons. Limits on caliber size shall be in accordance with the MIL-HDBK-1027/3B/ or National Rifle Association Range Manual subject to the physical constraints of the property.

(14) No concussion type of explosives shall be permitted unless authorized in accordance with division (S)(19) below.

(15) No military, para-military or militia type activities or maneuvers, including, but not limited to hand-to-hand combat training, swamp or guerrilla warfare techniques, no incendiary type firings, infiltration course type training and the like be permitted unless authorized in accordance with division (S)(19) below.

(16) All actual firing activities will be directed toward either moving or stationary targets only.

(17) Any overnight or temporary storage of weapons, ammunition and/or explosives must meet the Bureau of Alcohol, Tobacco, Firearms and Explosives storage and stand-off safety standards.

(18) Each commercial firing range shall be posted indicating the allowable caliber of weapon allowed and any other applicable rules.

(19) Any commercial firing range activity not specifically mentioned within the foregoing shall be prohibited unless set as a condition of the special use permit.

**Camden County Board of Commissioners
AGENDA ITEM SUMMARY SHEET**

Item Number: 7.I

Consent Agenda

Meeting Date: September 8th, 2015
Attachments: 2 (7Pages)
Submitted By: Admin

**ITEM TITLE: Shiloh Baptist Church
Historical Road Marker**

MOTION MADE BY:	
S. Duckwall	
G. Meiggs	
M. McLain	
C. Riggs	
T. White	
NO MOTION	
VOTE:	
S. Duckwall	
G. Meiggs	
M. McLain	
C. Riggs	
T. White	
ABSENT	
RECUSED	

SUMMARY:

Staff received the attached resolution request.

RECOMMENDATION:

Review & Approve

RESOLUTION No. 2015-09-01

**IN SUPPORT FOR A STATE HISTORICAL HIGHWAY MARKER IN
SHILOH TOWNSHIP, CAMDEN COUNTY TO COMMEMORATE THE
RICH HISTORY OF THE SHILOH BAPTIST CHURCH**

WHEREAS, the Shiloh Baptist Church was first organized by early colonists by or before 1727 and provided the community a place of worship and fellowship; and

WHEREAS, the Shiloh Baptist Church was led by many able pastors including Reverend Henry Abbott who served during the American Revolutionary War and was elected to the State Congresses in 1776; and

WHEREAS, the present sanctuary was built in 1848-49 and was occupied by Federal Troops during the Civil War for use as an arsenal; and

WHEREAS, the Shiloh Baptist Church continues to flourish and is known and recognized by business and civic leaders throughout Camden County; and

WHEREAS, the Camden County Board of Commissioners are of the unanimous opinion that Shiloh Baptist Church is an historical treasure of the State of North Carolina and to the Camden County community and that its historical significance should be memorialized.

NOW THEREFORE, BE IT RESOLVED by the Camden County Board of Commissioners that the North Carolina Department of Cultural Resources, Office of Archives and History, through its Highway Historical Marker Advisory Committee is hereby respectfully requested to erect a State Historical Highway Marker at the site of the Shiloh Baptist Church.

This is the 8th day of September, 2015.

Michael McLain - Chairman

ATTEST:

(SEAL)

Angela Wooten – Clerk

Shiloh Baptist Church

Linking the past to the future, through the present.

[Home](#) [About Us](#) [Join Us](#) [Ministries](#) [Guests](#) [Resources](#) [Contact Us](#) [Photos](#) [Prayer Request](#)

(Please be patient with us while we make improvements to this page starting 5/26/2015)

A Brief History

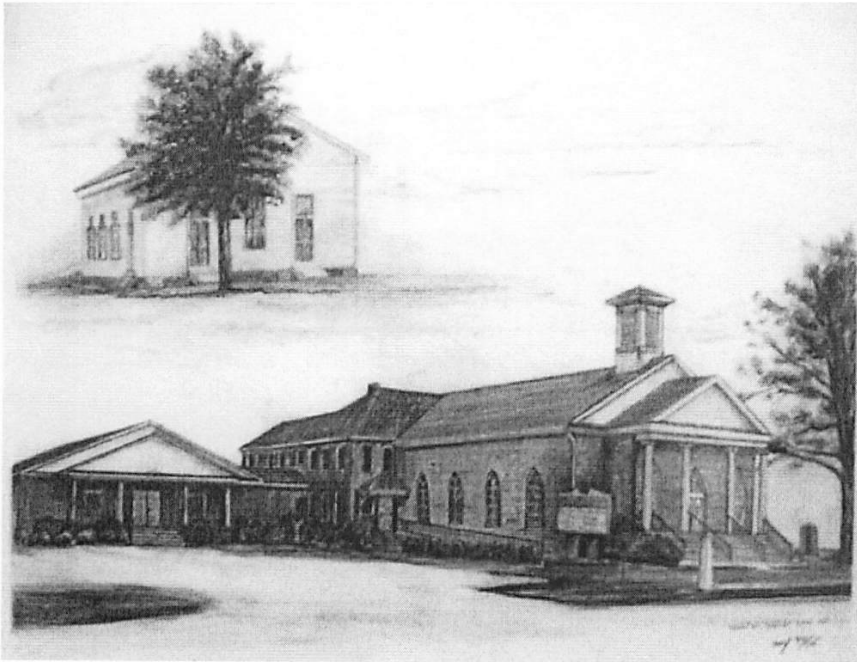

Drawing by Michael W. Holcomb 2008

In 1660 and 1662 Yeopim King Kiscutanewh granted land to Nathaniel Batts and George Durant recognized as the first land deeds in North Carolina. By 1697 the Yeopim leaders complained to the colonial government about nearby European settlers encroaching on their lands. In 1704 the Executive Council granted 10,240 acres (16 square miles) along both sides of the North River to the Yeopim Nation. The deed for the reservation granted the Yeopim exclusive hunting and fishing rights. The area known as Indiantown was only about six miles north of Raymons/Raymonds Creek where the first worshipers of what would become Shiloh Baptist Church first began to meet.

The beginnings of Shiloh Baptist Church are humble and span back to before 1727, when a Baptist missionary named Paul Palmer, organized the Shiloh Baptist Church. William Burges (spelled with one "s") was the first pastor. The total population of the area known as North Carolina was about 30,000 people. The entire Albemarle area accounted for approximately 4,000 residents. In 1711, the Tuscarora Indians, who lived on the southern side of the Albemarle Sound, went on the warpath and almost overwhelmed the colonists of the Albemarle region. The Yeopim/Yawpim Nation who had settled around the North River on the nearest reservation to what is now the township of Shiloh, in Camden County were not greatly involved in the Tuscarora Wars since the two tribes were not allied with one another. Most likely, there were more Indians than colonists living in the area around the shores and rivers of the Albemarle region. Since the colonists were scattered and transportation was difficult, the organized church began meeting once a month in the home of William Burges which was located about three miles south of the present location of Shiloh Baptist Church at the head of Raymons/Raymonds Creek. Prior to 1775, present day Camden County was still a part of Pasquotank County requiring that official business be carried across the Pasquotank River to be recorded.

The earliest known existing record of the Shiloh Baptist Church is a petition to the Court of Pasquotank Precinct, requesting that the court record the meeting of the Baptist Congregation. This petition was signed on the bottom right by William Burges; also to the left are the signatures of Paul Palmer, Francis Brocket, Thomas Herenton (modern spelling Harrington), William Jones, Philip Torksey (there are several modern spellings including Toxey and Doxey), Robert Wasson, and Charles Scarborough (once misinterpreted from the script on the original document as "Leutrough"). Shiloh Baptist Church is the oldest continually worshipping Baptist church in North Carolina. By 1727 people were worshipping in the home of pastor, Rev. William Burges. The number of worshipers grew and in 1736 Reverend Burgess

built a small church next to his home. The petition was made by the church to the King's Court September 5, 1729 for them to continue worshipping as they had been for several years. A photographic copy is available in the church today.

According to Morgan Edwards, an early Baptist Historian, a meeting house was built on the land of the pastor, William Burges in 1736. Edwards gave the membership at that time as about 30. His records also show January 20, 1758, as the date when the constitution of the church changed from the General to the Particular Order. He lists the names of 12 members who had "*embraced the particular scheme*" and states that "*in 13 years they increased from 12 to 192*" and that "*most of the brethren of the General Persuasion*" had rejoined them. When these 12 defected to the Particular Baptists, they erected a separate meeting house, described by Edwards as being fifty feet by twenty-five feet on the ground owned by the pastor, John Burges, son of William Burges. The meeting house was located on Portahonk Creek, a distance of about three miles from the 1736 meeting house, and across the road from the present building.

The new location near the present location was now about halfway between Raymons Creek and Indiantown. A marker was placed on this site in 1974. In 1723, the Yeopim Indians had gained permission to sell their reservation land and began to sell their land in multiple parcels over time. By this time the Yeopim leaders had taken on English names such as John Durant, John Barber, John Hawkins, Henry Gibbs, and George Durant so it becomes difficult to determine from any surviving primary documents the degree of interaction between the church and the Yeopim people from the reservation. Evan Forbes served the church as pastor 1829-1842, 1845-1848, 1851-1853, and 1853-1857. James Forbes and his family, originally from Scotland, were admitted to North Carolina on October 20, 1701. James Forbes was granted 532 acres on the east side of the Pasquotank River on October 21, 1715. This land was adjacent to the Yeopim Reservation so it is reasonable to think that there was at least some interaction between the Forbes family and the Yeopim. Wesley Episcopal Methodist Church in Old Trap began meeting around 1834. Providence Baptist Church located in what is now Shawboro in Currituck County was originally called Providence Meeting House in 1817 and was constituted as a Baptist church in 1826. Although the evidence is mostly circumstantial, it is likely that if the Yeopim Indians accepted Christianity and assimilated with the Colonial Europeans that Shiloh is where they would have had the greatest opportunity to do so.

The present sanctuary, which originally included a balcony for Negro Members, was built in 1848-49, at the cost of \$2400.00. This meeting house was built on land included in John Burges' estate. In 1774, John's son, Dempsey Burges, conveyed the property to the Baptist Society.

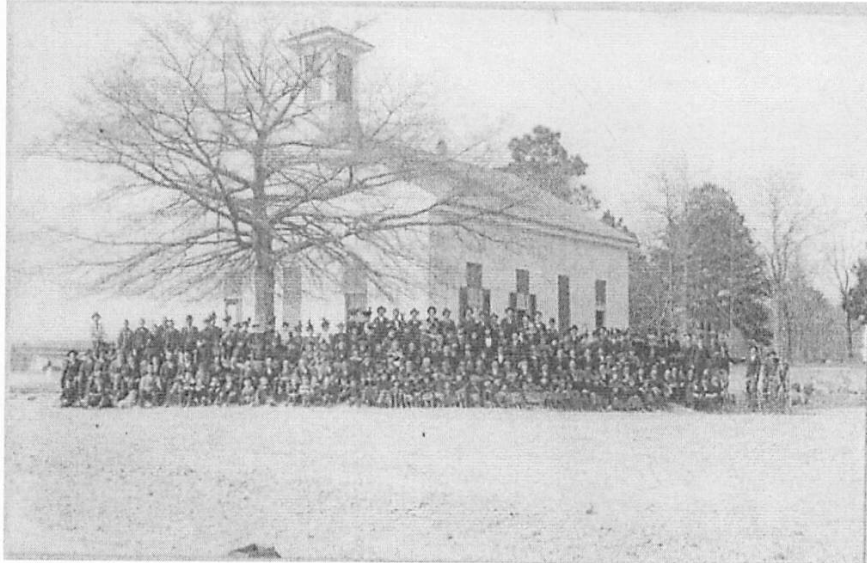

This photograph made by Zoeller, Morgan Company around 1895 pictures the congregation of Shiloh Baptist Church soon after the steeple was added to the building. Mary and Luke Stevens donated funds and labor to add the steeple in 1878. Luke Stevens died from flu and pneumonia on March 8, 1878 and Mary Stevens died from the flu ten days later. (Courtesy of Linda Ann Mansfield.) Page 89, Camden County, by A. Burgess Jennings, Arcadia Publishing.

Several additions have been made to the 1849 structure. The Steeple and bell were added in 1878. The present windows were installed in 1913.

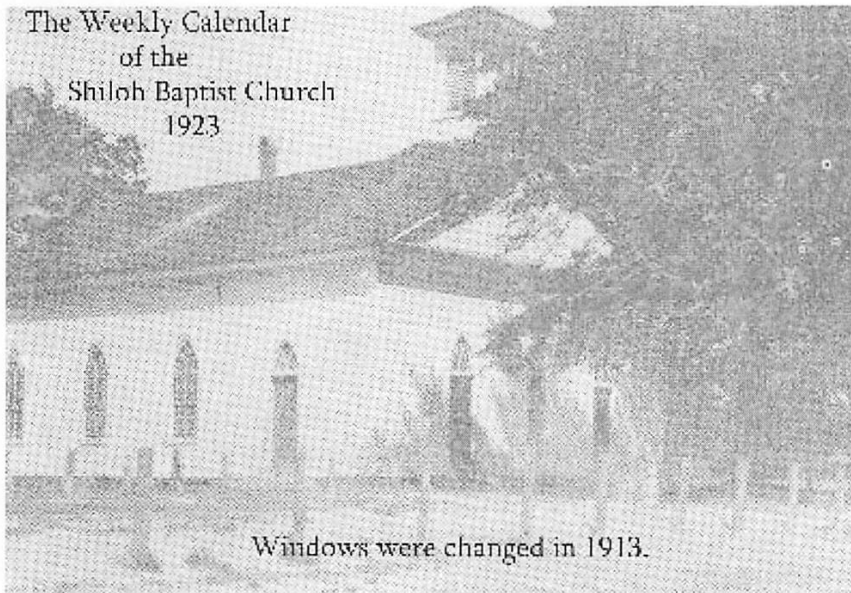

Eighteen Sunday School rooms were built in 1924 and fourteen more were added in 1954-55.

This photo of Shiloh Baptist Church taken in 1924 shows that the church had now added an addition to the rear of the building.

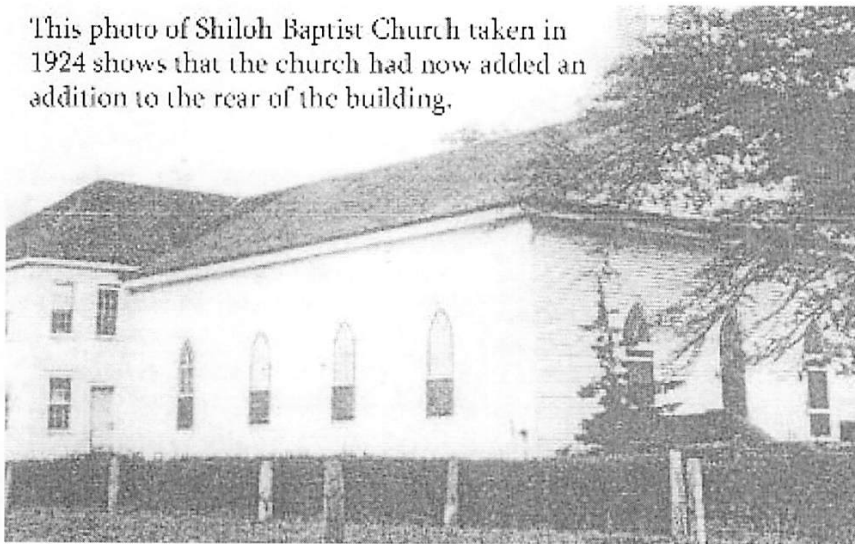



Shiloh Baptist Church: 1933-1935

The present entrance and vestibule were added in 1947. When the sanctuary was renovated in 1949, the baptistry was installed, the choir loft was built and an electric organ was purchased. This organ was replaced in 1973. New pews were purchased in 1955, and the structure was bricked in 1966.



SBC was bricked in 1966

The sanctuary was air-conditioned in 1969, and in 1974, air conditioning was installed throughout the rest of the church. New pews were purchased in 1955, and the structure was bricked in 1966. The Fellowship Hall, Pastor's Study, and offices were added in 1992. In 1994, the Children's Playground was built.



Although the spiritual growth of the church cannot be accurately measured, a glimpse of its membership at specific times, during its history, might be significant. We do not know how many members there were when the church was organized in 1727. In 1736, the membership was given as about 30. By 1800, membership had increased to about 200. Associational minutes record membership in 1848 at about 369, 316 whites and 53 blacks. In 1857, membership had grown to 448, 369 whites and 79 blacks.

Services were interrupted during the Civil War, while Federal Troops occupied the building and used it as an arsenal. Associational minutes of 1890 list 91 male members and 316 female members. In 1925, there was a total of 461 members; in 1961, records show 617 members. In 2002, there were 457 members listed. In 2008, we had approximately 481 members on the church roll.

The church has not been without some controversy. As mentioned earlier, in 1758 the membership split over doctrinal differences. The minutes of the Kehukee Association reveal that Shiloh Church was admitted to that association in 1771, but was expelled in 1775 because the church and pastor, Henry Abbott, took a stand against proposed reforms. The church was readmitted in 1778 and remained with that association until 1806, when the Chowan Association was formed.

There have been four name changes since the church was formed. The first name given to the church was Burges' Meeting House. It was changed to North Meeting House and later, to Camden Meeting House. In 1812, the name Shiloh was adopted. The name Shiloh is biblical and means peaceable or pacific. Shiloh was the ancient city of Ephraim, which was one of the earliest and most sacred Hebrew sanctuaries.

- In 1831, Sunday School was organized within the church.
- We do not know when the Women's Missionary Union (WMU) was organized, but it was listed in the associational minutes in 1906.
- In January 1919, Reverend Joel Brown became the first full time pastor.
- The first Training Union was organized in 1921.
- Shiloh extended its ministries to the surrounding area by organizing nine churches:

Pungo, now known as Oak Grove Baptist, Princess Anne County, VA, in 1762
 Yoppim, in Chowan County, NC, in 1771
 Cowenjock (now spelled "Coinjock"), in Currituck County, NC, in 1780
 Knobs Crook, now known as First Baptist, in Elizabeth City, NC in 1786
 Flatty Creek, now known as Salem Baptist, in Weeksville, NC, in 1790
 Sawyer's Creek, in Camden, NC 1790
 Shady Grove, in Currituck County, NC, in 1828
 Oak Ridge, in Riddle (Camden County) NC, in 1889
 Pleasant Grove, in Indiantown (Camden County) NC, in 1891
 (Oak Ridge, and Pleasant Grove no longer exist, though Shiloh Baptist absorbed much of the memberships of the two churches.)

Many ministers have been ordained here at Shiloh Baptist. They are listed as follows:

William Burges Sr.	William Burges Jr.	John Burges
Joshua White	Thomas Etheridge	David Duncan
William Lurry	David Biggs	Lemuel Burkitt
Evan Forbes	Jesse Bray	Benjamin Dozier
Abner Berry	Wells Briggs	Charles S. Burgess
John L. Pritchard	A.W. Burfoot	Gideon Bray

Charles B. Williams
Don Clinton

M.B. Toxey
Steve Hughes

James B. Sawyer
Kenneth Wallace

The most noted of these, was Dr. Charles B. Williams. Dr. Williams was ordained in 1890 and later became an educator and author. He taught Greek at Southwestern Seminary, from 1905-1919. He held the position of Dean the last six years at Southwestern. He served as president at Howard College from 1919-1921. Dr. Williams went on to Mercer University, in Georgia, where he taught New Testament Interpretation for four years. He then became a professor of Greek and Ethics at Union University in Tennessee until 1932. Dr. Williams most noted literary work is his translation of the New Testament into the language of the people. (Moody Press 1949) In 1941, Dr. Williams returned to Shiloh and served as pastor until 1946.

In 1968, Shiloh Baptist extended its ministries by broadcasting the Morning Worship Service over the radio in Elizabeth City, NC, at WCNC. The broadcast continued until 1980.

Shiloh Church has also be influential in political affairs. One of our early pastors, Henry Abbott, was elected to both the State Congress Meetings in Halifax, NC in 1776. On April 12, 1776, the first Congress adopted the famous Halifax Resolves. The last paragraph of the Halifax Resolves reads in part: "*Resolve, that the delegates for the Colony in the Continental Congress, be empowered to concur with the delegates of the other colonies in declaring Independency...*"

The Provincial Assembly met again in Halifax, in November of that same year. One of Abbott's assignments was with a "*committee to form, and lay before this House a Bill of Rights, and form a constitution for the government of this state*". Tradition credits Abbott with being the author of Article Nineteen of the State Constitution, "*That all men have natural and inalienable rights to worship Almighty God according to the dictates of their conscience.*"

Dempsey Burges was a member of the majority of the congress convened during the Revolutionary period, including the two at Halifax, in 1776. Burges became Lt. Colonel in the Continental Army, during the Revolutionary War and was a member of the United States Congress from 1795-98. According to Baptist Historic Papers, in 1776, the deacons of Shiloh Church were asked by the newly elected governor, to serve as Magistrates and Conservators of the peace, until the machinery of state government could be put into operation.

In 1990, Shiloh church history added a new page. Earline Revelle was ordained as the first woman deacon to serve in the church and served Shiloh Baptist Church as an active deacon for three terms.

In 1995, Andrea Garrett was hired as an American Sign Language Interpreter.

In May of 2000, Shiloh Baptist embarked on a more relaxed style of worship. The Early Worship Service began. It provided a relaxed atmosphere with Praise and Worship Music, a condensed version of the sermon for the 11:00 Worship Service, and a more contemporary worship experience. This worship experience still goes on in 2015.

**Camden County
South Camden Water & Sewer District**

AGENDA ITEM SUMMARY SHEET

Item Number 4.A

New Business

Meeting Date: 9/8/15

Attachments: 1 (1 Pages)

**Submitted By: David Credle, Public Works
Manager**

ITEM TITLE: Monthly Update to the Board

SUMMARY:

Report to the Board about the work orders, locates and general maintenance water / sewer items for the month of August.

RECOMMENDATION:

Information only.

MOTION MADE BY:	
S. Duckwall	
G. Meiggs	
M. McLain	
C. Riggs	
T. White	
NO MOTION	
VOTE:	
S. Duckwall	
G. Meiggs	
M. McLain	
C. Riggs	
T. White	
ABSENT	
RECUSED	

South Camden Water & Sewer Board
Monthly Work Order Statistics Report
Period: July 2015

	Submitted Work Orders	Completed Work Orders	Percentage Completed	Status of Uncompleted Work Orders
Water Collection/Distribution	233	233	100%	0
Sewer	21	21	100%	0

Locates:

Water Line: 53

Sewer Line: 20

Water & Sewer, same ticket: 3

Public Works Director Notes/Comments:

(Outstanding maintenance issues, staffing issues, etc.)

**South Camden Water & Sewer District
Board of Directors
AGENDA ITEM SUMMARY SHEET**

MOTION MADE BY:	
S. Duckwall	
G. Meiggs	
M. McLain	
C. Riggs	
T. White	
NO MOTION	
VOTE:	
S. Duckwall	
G. Meiggs	
M. McLain	
C. Riggs	
T. White	
ABSENT	
RECUSED	

Item Number: 4.B

New Business

Meeting Date: September 8, 2015

Attachments: 3 (12 Pages)

Submitted By: Michael Renshaw, County Manager

ITEM TITLE: Construction of Seymour Drive Well Site and Raw Water Main

SUMMARY:

In 2014 the County acquired approximately five acres of land near the intersection of Seymour Drive and Country Club Road. In accordance with needs identified in the Long-Range Water and Sewer Comprehensive Master Plan 2010-2030 and the approved Capital Improvement Plan 2016-2020 (CIP), the construction of the Seymour Drive Well Site and raw water main connecting the Site to the existing Reverse Osmosis Water Treatment Plant will better position the County to meet future public drinking water needs for both residential and commercial development. This project is listed in the approved CIP as a Priority 1 level project for FY 15/16.

The Seymour Drive Well Site property was chosen due to its close proximity to the current Water Treatment Plant (significantly reducing construction costs related to the extension of the 12 inch raw water main). The construction of this new well site will produce an additional 150-200 GPM of raw water (the actual number may be more or less upon construction). The WTP reverse osmosis train requires 715 GPM to operate. We now operate a deep and shallow well at each site. The deep wells have ammonia levels that when concentrated will soon become an issue under the county’s current discharge permit.

The county has retained the services of engineering consultants Diehl & Phillips, P.A. and have been provided all required plans, specifications, and construction contract documents need for project bidding. The County Attorney is currently working with the Public Works director to revise the location of a 45 foot easement on the property as well as obtaining the required harmonics letter from Dominion Power.

Budget Amendment 2015-16-BA002 has been prepared by the Finance Officer in the amount of \$485,000 to cover the expenses related to this project. Funding will be drawn from Capital Reserve and Water/Sewer Upgrade Fund Balances.

RECOMMENDATION:

The County Manager recommends that the Board of Commissioners approve Construction of Seymour Drive Well Site and Raw Water Main project funding in the amount of \$485,000 and authorize the County Manager to proceed with soliciting construction bids.

DIEHL & PHILLIPS, P.A.

CONSULTING ENGINEERS
1500 Piney Plains Rd., Suite 200
Cary, North Carolina 27518
Telephone (919) 467-9972 – Fax (919) 467-5327

WILLIAM C. DIEHL, P.E.
JOHN F. PHILLIPS, P.E.
ALAN R. KEITH, P.E.

June 26, 2015

County of Camden
P.O. Box 190
Camden, NC 27921

ATTN: Mr. David Credle, Public Works Director

Re: Seymour Well Project Construction Phase Budget

Dear Mr. Credle:

I have prepared for your use an estimated construction phase project budget for the referenced project. As we have discussed, these figures are only an estimate as I cannot control contractors pricing.

Contract 1- Raw Water Main: Estimated Construction Cost \$125,000
Contract 2- Seymour Production Well: Estimated Construction Cost \$250,000
SCADA: Estimated Cost \$35,000
Project Contingency (10%) \$40,000
Construction Phase Engineering Services (Bid, Contract Admin, Observation) \$35,000

Total Estimated Construction Phase Project Cost: \$485,000.00

Please let me know if I can provide further information.

Sincerely,

Diehl & Phillips, P.A.



William C. Diehl, P.E.

DIEHL & PHILLIPS, P.A.

CONSULTING ENGINEERS
1500 Piney Plains Rd., Suite 200
Cary, North Carolina 27518
Telephone (919) 467-9972 – Fax (919) 467-5327

WILLIAM C. DIEHL, P.E.
JOHN F. PHILLIPS, P.E.
ALAN R. KEITH, P.E.

June 26, 2015

County of Camden
P.O. Box 190
Camden, NC 27921

ATTN: Mr. David Credle, Public Works Director

Re: Seymour Well Design Phase Engineering Services

Dear Mr. Credle:

In accordance with the February 12, 2015 Agreement for Professional Services, I am pleased to submit two sets of plans, specifications and contract documents (hereinafter referred to as “documents”) for the referenced project. These documents are stamped “Final Design-Not Released for Construction”; this stamp should be construed to mean that the documents are as complete as possible at this time, but that the documents will need to be thoroughly reviewed before bids or construction take place. This review should be focused on looking for anything that may have to be changed due to the passage of time between now and then, as well as completing numerous dates in the documents that cannot be completed until either a bid date is established, or bids have been taken. I have also included a CD of the plans.

There are still a few outstanding items that need to be accomplished before bids can be taken. These include:

- Camden County needs to acquire a bore pit easement shown at the raw watermain tie-in.
- Camden County needs to revise the 45’ easement on the well site and record a revised plat map.
- Camden County needs to clear and improve the 45’ access easement on the well site.
- Dominion Power needs to furnish the harmonics letter we met with them about. This letter needs to be included in the Appendix to the contract documents for Contract 2.
- Camden County needs to re-sample the test well and have silica re-analyzed to determine if the silica level precludes the use of the well site.

CAMDEN COUNTY WATER SYSTEM IMPROVEMENTS CONTRACT 1 - RAW WATER MAIN EXTENSION

INDEX OF DRAWINGS

1	RAW WATER MAIN FROM SEYMOUR PRODUCTION WELL AND ALONG NCSR 1138 (SEYMOUR DR. & CHANTILLY RD.)
2	PLAN OF EXIST. RAW WATER MAIN ALONG NCSR 1138 (CHANTILLY RD.) - FOR PIGGING OPERATION
3	MISCELLANEOUS DETAILS

DIEHL & PHILLIPS, P.A.
 CONSULTING ENGINEERS - I.C. NO. C-0465
 1500 PINEY PLAINS RD., SUITE 200
 CARY, N.C. 27518 • (919) 467-9972

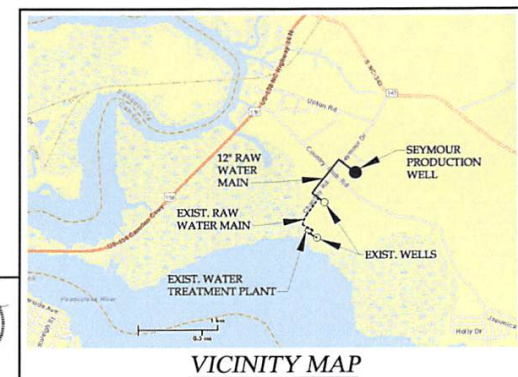

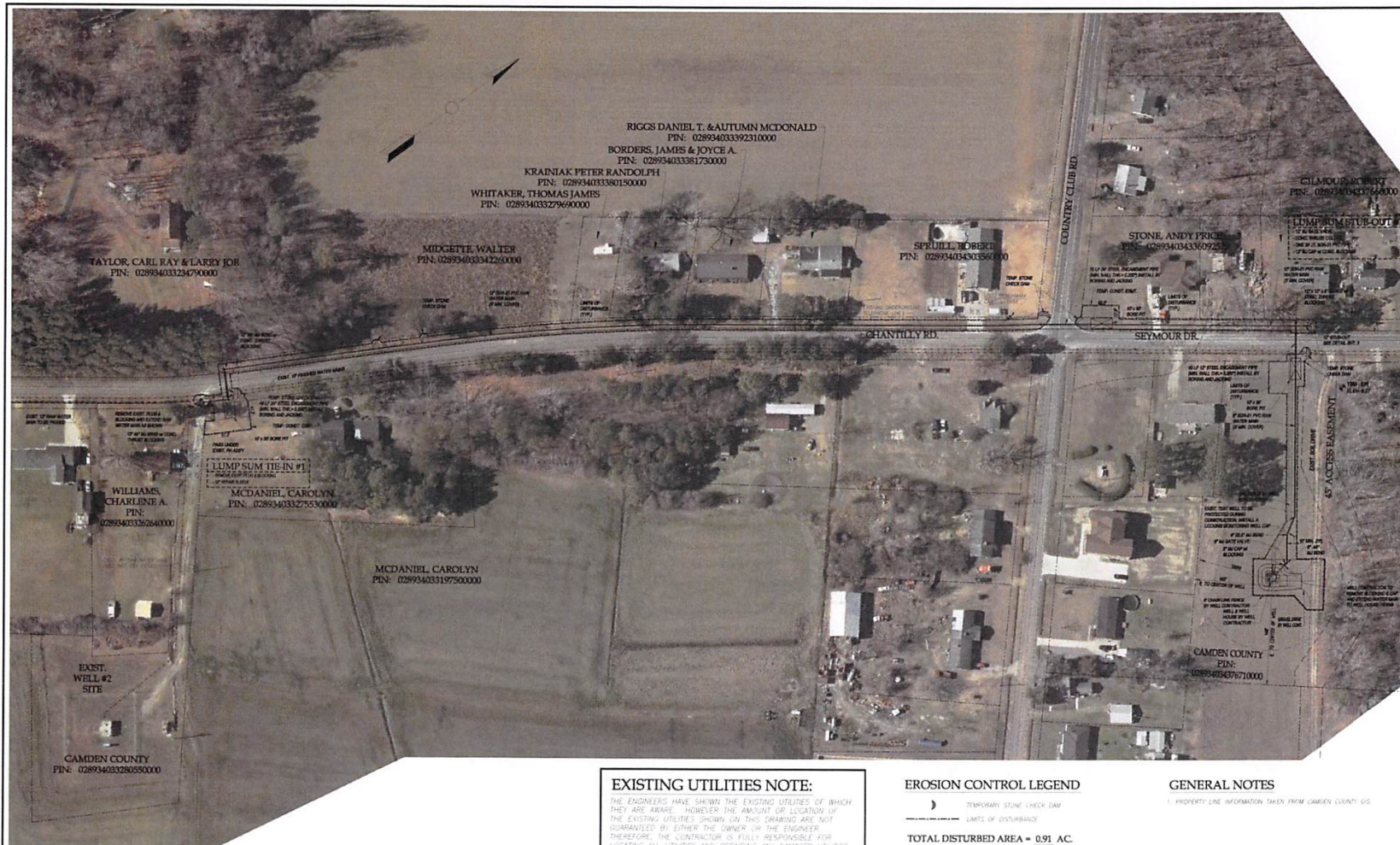

EXISTING UTILITIES NOTE:
 THE ENGINEERS HAVE SHOWN THE EXISTING UTILITIES OF WHICH THEY ARE AWARE. HOWEVER, THE AMOUNT OR LOCATION OF THE EXISTING UTILITIES SHOWN ON THIS DRAWING ARE NOT GUARANTEED BY EITHER THE OWNER OR THE ENGINEER. THEREFORE, THE CONTRACTOR IS FULLY RESPONSIBLE FOR LOCATING ALL UTILITIES AND REPAIRING ANY DAMAGED UTILITIES AT HIS OWN EXPENSE, WHETHER OR NOT THEY ARE SHOWN ON THIS DRAWING.

EROSION CONTROL LEGEND
 ———— TEMPORARY STONE CHECK DAM
 - - - - - LIMITS OF DISTURBANCE
TOTAL DISTURBED AREA = 0.91 AC.

GENERAL NOTES
 1. PROPERTY LINE INFORMATION TAKEN FROM CAMDEN COUNTY GIS

<p>DIEHL & PHILLIPS, P.A. CONSULTING ENGINEERS 1500 FINE PLAINS RD., SUITE 200 CARY, N.C. 27513 • 919-682-9972</p>	<p>D&P</p> <p>CAMDEN COUNTY WATER SYSTEM IMPROVEMENTS PROJECT CONTRACT - RAW WATER MAIN EXTENSION</p>
<p>RAW WATER MAIN FROM SAND AND GRAVEL SANDY WELL AND ALONG NCSR 1138 (SEYMOUR DR. & CHANTILLY RD.)</p>	<p>1</p> <p>8/10/16</p>



<p>PLAN OF EXIST. RAW WATER MAIN IMPROVEMENTS PROJECT RD. # FOR PENDING OPERATION</p>	<p>D&P</p>	<p>DIEHL & PHILLIPS, P.A. CONSULTING ENGINEERS 300 FIRST YEARS RD., SUITE 200 CAMP, NC 27514 • (919) 487-9979</p>	<p>CAMDEN COUNTY WATER SYSTEM IMPROVEMENTS PROJECT CONTRACT 1 - RAW WATER MAIN EXTENSION</p>
<p>2</p>	<p>3</p>	<p>6/10/15</p>	<p>3</p>

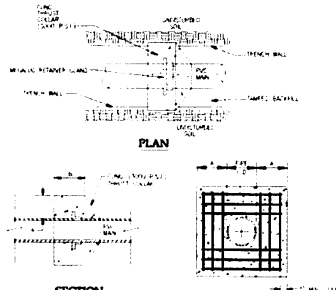

NOTES:

1. COLLAR SHALL BE CONCRETE OR METAL, AS NOTED.
2. COLLAR SHALL BE REINFORCED WITH #4 BARS AT 12" ON CENTER.
3. COLLAR SHALL BE REINFORCED WITH #4 BARS AT 12" ON CENTER.
4. COLLAR SHALL BE REINFORCED WITH #4 BARS AT 12" ON CENTER.
5. COLLAR SHALL BE REINFORCED WITH #4 BARS AT 12" ON CENTER.

REINFORCING

SCHEDULE

ITEM	DESCRIPTION	QTY	UNIT
1	STANDARD THRUST COLLAR	1	EA
2	STANDARD THRUST COLLAR	1	EA

STANDARD THRUST COLLAR INSTALLATION
NO SCALE

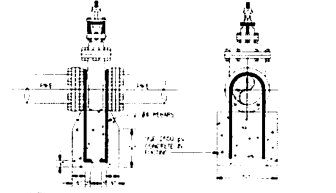

TYPE OF MATERIAL

ITEM	DESCRIPTION	QTY	UNIT
1	STANDARD GATE VALVE FOOTING	1	EA
2	STANDARD GATE VALVE FOOTING	1	EA

STANDARD GATE VALVE FOOTING
NO SCALE

MINIMUM CONCRETE BLOCKING (CY)

ITEM	DESCRIPTION	QTY	UNIT
1	MINIMUM CONCRETE BLOCKING (CY)	1	CY
2	MINIMUM CONCRETE BLOCKING (CY)	1	CY

STANDARD REACTION BLOCKING
NO SCALE

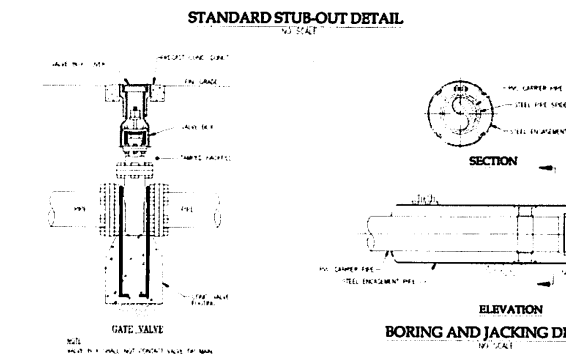
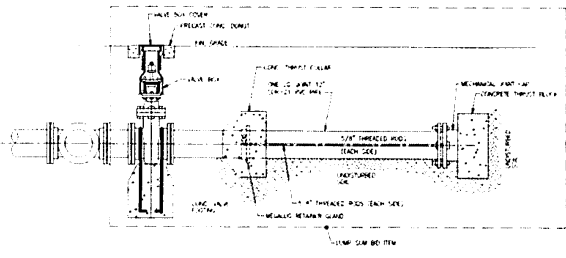

STANDARD VALVE BOX INSTALLATION
NO SCALE

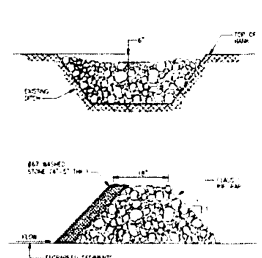
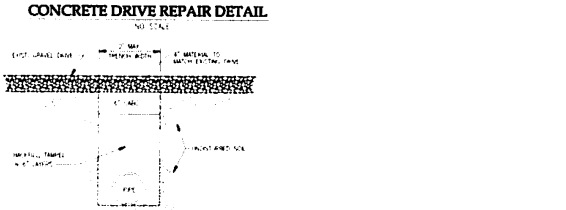
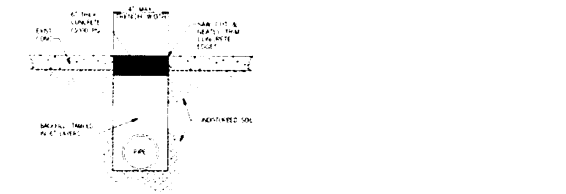

TEMPORARY STONE CHECK DAM
NO SCALE

CONSTRUCTION SEQUENCE

1. VERIFY THE APPROVAL AND OTHER APPLICABLE PERMITS.
2. OBTAIN THE CONSTRUCTION CONFERENCE.
3. FURNISH THE CONTRACT DOCUMENTS TO THE OWNER.
4. CLEAR THE AREA OF OBSTACLES FOR INSTALLATION OF THE WATER MAIN.
5. INSTALL THE WATER MAIN.
6. FURNISH THE OWNER WITH A COMPLETE SET OF AS-BUILT DRAWINGS, INCLUDING A SCHEDULE OF MATERIALS, AND A SCHEDULE OF WORK, INCLUDING A SCHEDULE OF VALUE, FOLLOWING COMPLETION OF CONSTRUCTION.
7. WHEN THE WORK IS COMPLETED, REMOVE ALL TEMPORARY MEASURES AND USE OF TEMPORARY MEASURES SHALL BE AT THE OWNER'S RISK.

MISCELLANEOUS DETAILS

DIEHL & PHILLIPS, P.A.
CONSULTING ENGINEERS, ARCHITECTS AND LANDSCAPE ARCHITECTS

D&P

CAMDEN COUNTY WATER SYSTEM IMPROVEMENTS PROJECT
CONTRACT 1 - SANITARY WATER MAIN EXTENSION

3



CAMDEN COUNTY WATER SYSTEM IMPROVEMENTS PROJECT CONTRACT 2 - SINGLE PRIME CONTRACT FOR SEYMOUR PRODUCTION WELL

INDEX OF DRAWINGS

1	SITE PLAN
2	WELL HOUSE - PLAN AND DETAILS
3	WELL HOUSE - ELEVATIONS
4	WELL HOUSE - ELECTRICAL POWER PLAN & LIGHTING PLAN
5	WELL HOUSE - ELECTRICAL POWER RISER DIAGRAM & PANEL SCHEDULES

DIEHL & PHILLIPS, P.A.
CONSULTING ENGINEERS - LIC. NO. C-0465
1500 PINEY PLAINS RD., SUITE 200
CARY, N.C. 27518 • (919) 467-9972

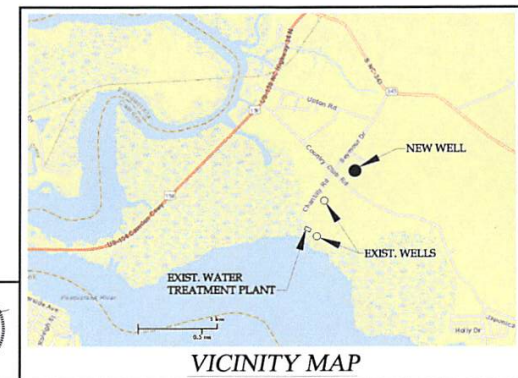



GENERAL NOTES
 1. PROPERTY LINE INFORMATION TAKEN FROM CAMDEN COUNTY GIS.

EROSION CONTROL LEGEND

- TEMPORARY STONE CHECK DAM
- LIMITS OF DISTURBANCE

TOTAL DISTURBED AREA = 0.91 AC.

EXISTING UTILITIES NOTE:
 THE ENGINEERS HAVE SHOWN THE EXISTING UTILITIES OF WHICH THEY ARE AWARE. HOWEVER THE AMOUNT OR LOCATION OF THE EXISTING UTILITIES SHOWN ON THIS DRAWING ARE NOT GUARANTEED BY EITHER THE OWNER OR THE ENGINEER. THEREFORE, THE CONTRACTOR IS FULLY RESPONSIBLE FOR LOCATING ALL UTILITIES AND REPAIRING ANY DAMAGED UTILITIES AT HIS OWN EXPENSE, WHETHER OR NOT THEY ARE SHOWN ON THIS DRAWING.



<p>DIEHL & PHILLIPS, P.A. CONSULTING ENGINEERS 300 PINE PLAINS RD., SUITE 200 CAMDEN, N.C. 28513 • (919) 627-9797</p>	<p>D&P</p>	<p>CAMDEN COUNTY WATER SYSTEM 1000 QUINCY STREET CONTRACT 1 - SINGLE PHASE CONTRACT FOR STORMWATER TREATMENT</p>	<p>SITE PLAN</p> <p>1 of 5</p>
---	-----------------------	---	---------------------------------------



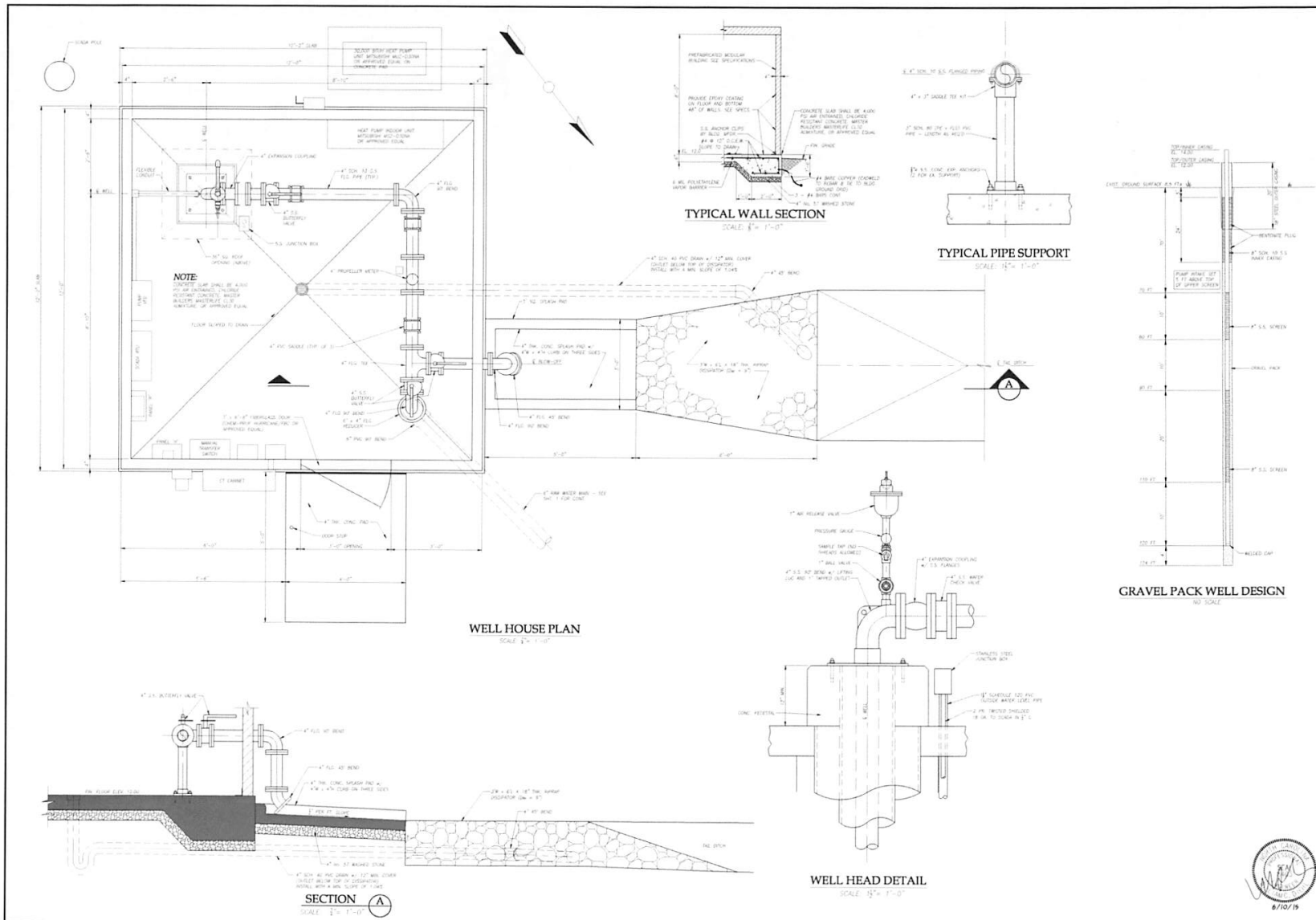

<p>DIEHL & PHILLIPS, P.A. CONSULTING ENGINEERS 300 PINE PLAINS RD., SUITE 300 CARY, N.C. 27513 • 919.462.9922</p>	<p>D&P</p>	<p>CAMDEN COUNTY WATER SYSTEM PROJECT NO. 19-0001 CONTRACT NO. 19-0001-001 FOR STATION PRODUCTION WELL</p>	<p>WELL HOUSE - PLAN AND DETAILS 2 8/10/19</p>
---	-----------------------	---	---

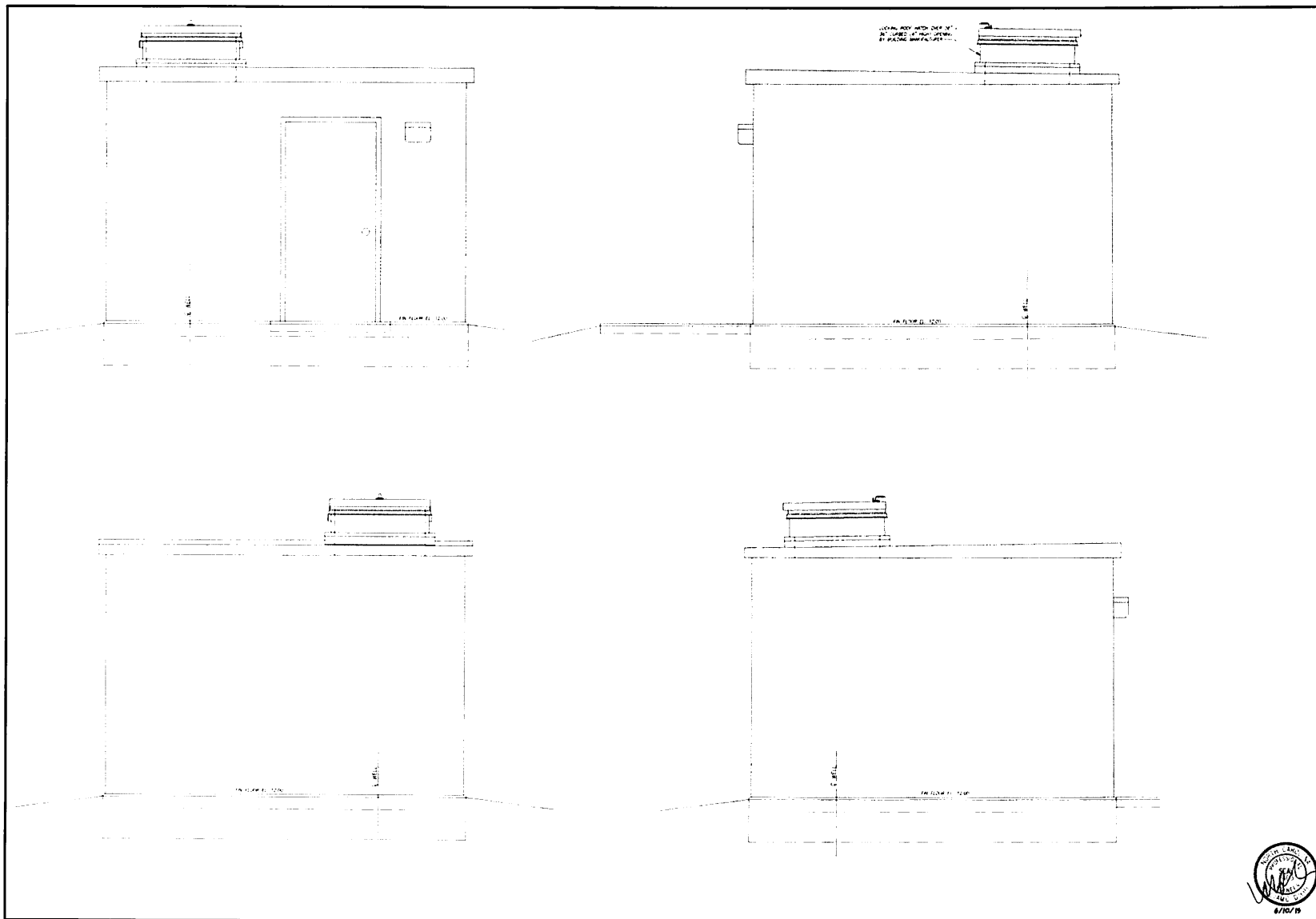

 WILLIAMS 11/10/19	WELL HOUSE - ELEVATIONS	CAMDEN COUNTY WATER SYSTEM IMPROVEMENTS PROJECT CONTRACT NO. 2018-0001 SPECIAL PROVISIONS 10/11/18	D&P	DIRHL & PHILLIPS, P.A. CORPORATE OFFICE 501 SOUTH PLAINS RD., SUITE 100 CAMDEN, NC 28520 • 813-657-8777	DATE
					SCALE
					PROJECT
					NO.
					DATE
					BY
					CHECKED
					DATE
					SCALE
					PROJECT
					NO.
					DATE
					BY
					CHECKED
					DATE

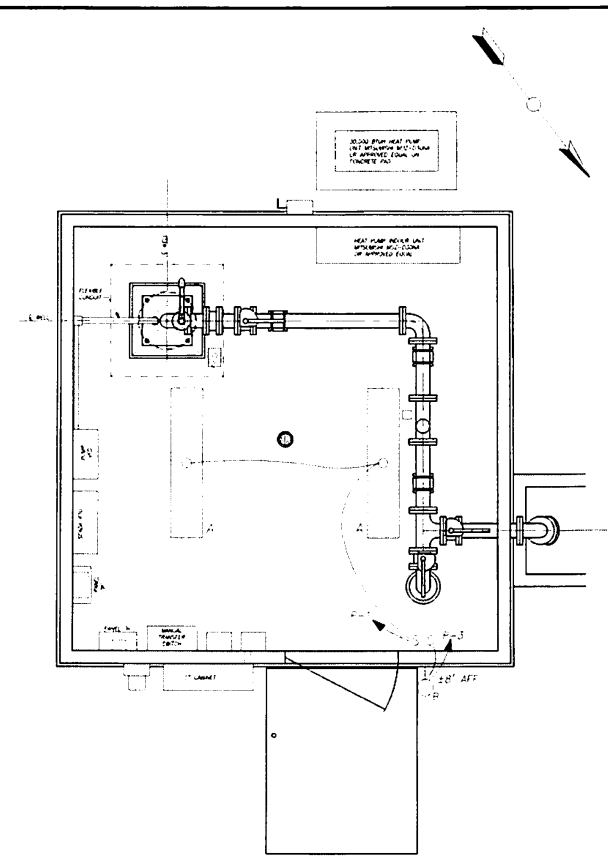
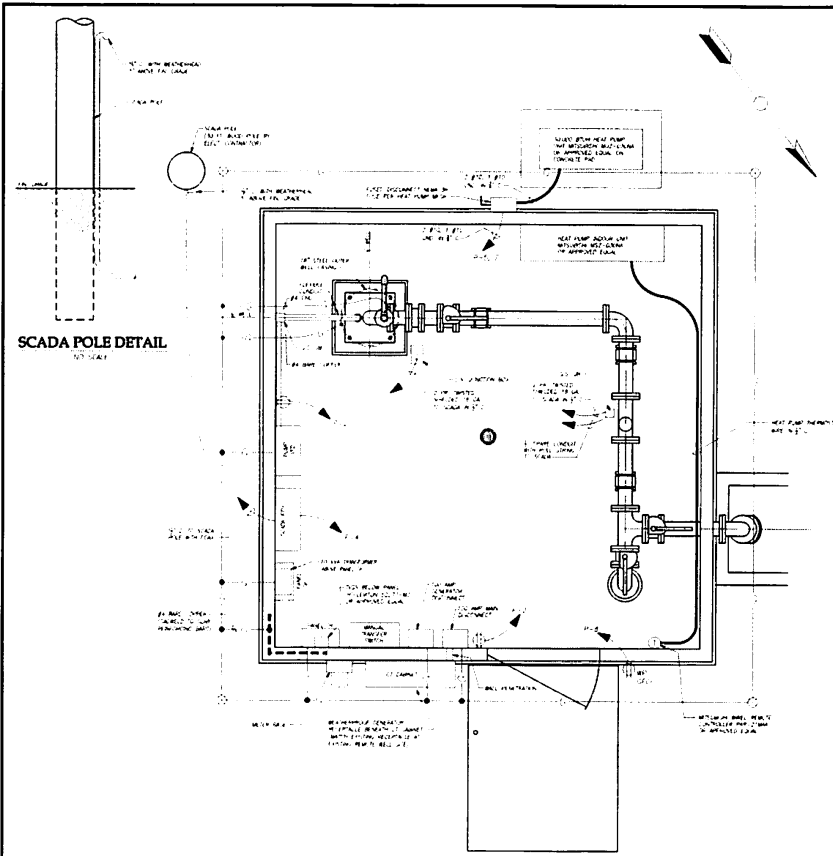

SYMBOL	MANUFACTURER & MODEL NUMBER	QTY	TYPE	WATTS	FUSE	WATTS	TOTAL WATTS	DESCRIPTION
A	LED 2' X 4' 2' 2000K	2	RECESSED	20			40	FULL SPECTRUM
B	LED 2' X 4' 2' 4000K	2	RECESSED	20			40	DAYLIGHT SPECTRUM
C	LED 2' X 4' 2' 5000K	2	RECESSED	20			40	COOL WHITE SPECTRUM

WELL HOUSE - ELECTRICAL POWER PLAN & LIGHTING PLAN

DsP

DIEHL & PHILLIPS, P.A.
CONSULTING ENGINEERS
CONTRACT NUMBER: 1600300
COUNTY NO. 2753 & 2754 (2017)

CAMDEN COUNTY WATER SYSTEM
CAMDEN, NJ 08102
CONTRACT NUMBER: 1600300
CONTRACTOR: DIEHL & PHILLIPS, P.A.

8/16/18

5

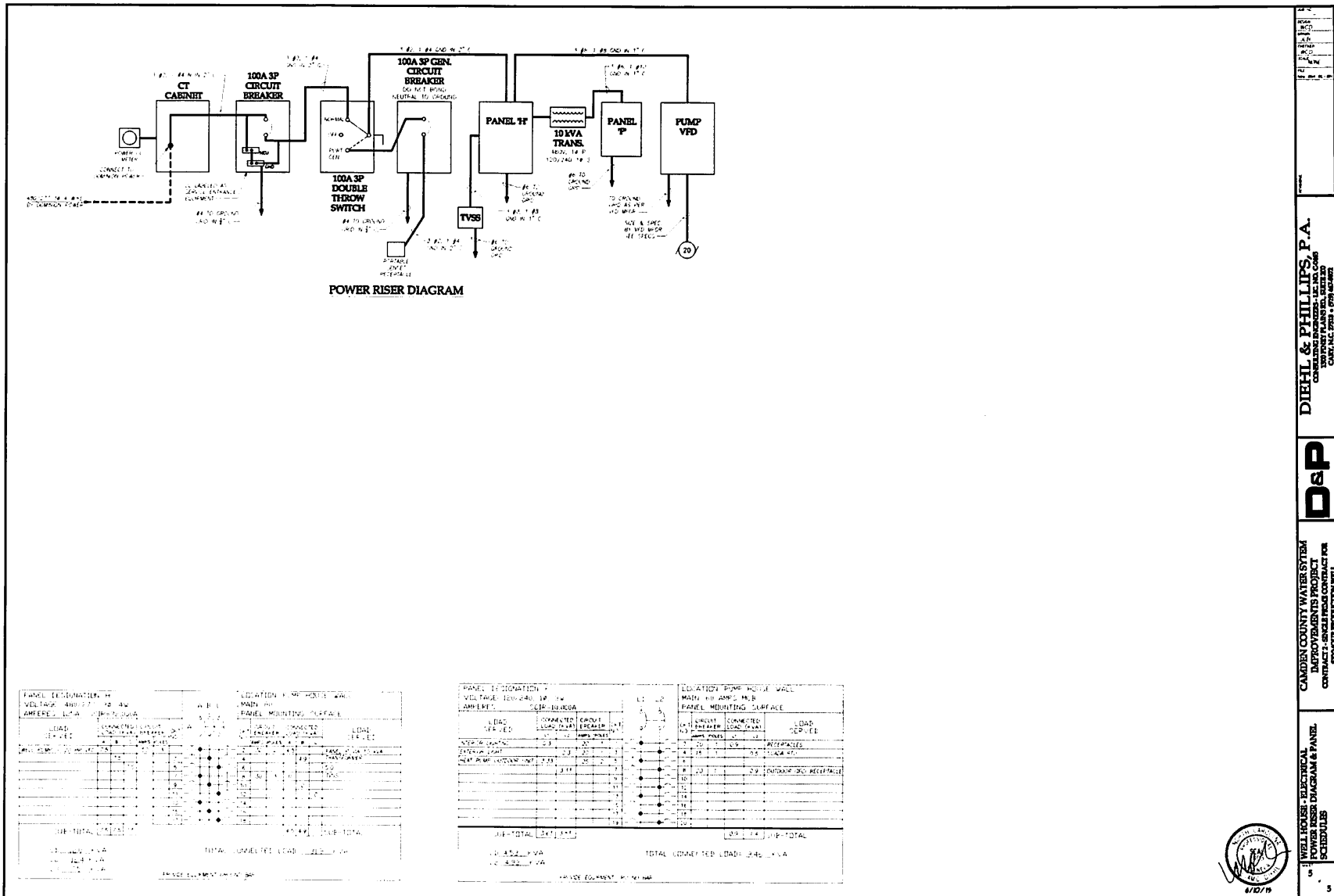

DIEHL & PHILLIPS, P.A.
 CONSULTING ELECTRICAL ENGINEERS
 1000 W. 10th Street, Suite 200
 Cary, NC 27513-4707
 P: 919.487.9900
 F: 919.487.9901
 WWW.DIEHLPHILLIPS.COM

D&P

CAMDEN COUNTY WATER SYSTEM
 IMPROVEMENT PROJECT
 CONSTRUCTION SCHEDULES
 303-550-3300

WELL HOUSE - ELECTRICAL
 IMPROVEMENT PROJECT
 CONSTRUCTION SCHEDULES

5

**Camden County Board of Commissioners
AGENDA ITEM SUMMARY SHEET**

Item Number:

INFORMATION

Meeting Date: September 8th, 2015
Attachments: 9
Submitted By: Various Department Heads

ITEM TITLE: INFORMATION

SUMMARY:

- A. Sales Tax Report
- B. Register of Deeds Monthly Report - July
- C. Register of Deeds Monthly Report - August
- D. EMS Monthly Report - July
- E. Library Monthly Report - August
- F. New Deputy Commissioners Appointed
- G. Mobile App for Job Seekers
- H. NCWorks Career Centers Give Free Food to Veterans

RECOMMENDATION:

MOTION MADE BY:	
S. Duckwall	
G. Meiggs	
M. McLain	
C. Riggs	
T. White	
NO MOTION	
VOTE:	
S. Duckwall	
G. Meiggs	
M. McLain	
C. Riggs	
T. White	
ABSENT	
RECUSED	

														Finance	17-Aug-15		
2014-2015																	
SALES TAX - REVENUE COLLECTION REPORT																	
	July	August	September	October	November	December	January	February	March	April	May	June	Totals	Budgeted			
Art. 39	\$44,058	\$42,111	\$22,402	\$52,255	\$54,114	\$41,782	\$53,444	\$43,525	\$43,288	\$45,900	\$44,030	\$42,237	\$529,146	\$525,000			
Art. 40	\$38,988	\$34,814	\$35,370	\$33,479	\$35,220	\$34,201	\$41,563	\$31,886	\$30,973	\$32,613	\$34,850	\$37,517	\$421,476	\$360,000			
Art. 42	\$10,488	\$9,928	\$6,185	\$12,046	\$12,308	\$9,971	\$12,478	\$10,325	\$10,146	\$10,713	\$10,240	\$10,172	\$125,000	\$125,000			
Art. 44	\$53	\$2	\$2	\$3	-\$3	\$0	\$0	-\$11	\$36	-\$11	\$0	\$0	\$71				
Totals	\$93,587	\$86,855	\$63,959	\$97,783	\$101,639	\$85,954	\$107,484	\$85,725	\$84,444	\$89,214	\$89,121	\$89,927	\$1,075,692				
Total Budgeted														\$1,010,000			
SALES TAX REVENUE- SCHOOL CAPITAL RESERVE FUND																	
	July	August	September	October	November	December	January	February	March	April	May	June	Totals	Budgeted			
Art. 40	\$16,709	\$14,920	\$15,158	\$14,348	\$15,094	\$14,658	\$17,813	\$13,666	\$13,274	\$13,977	\$14,936	\$16,079	\$180,631	\$150,000			
Art. 42	\$15,732	\$14,892	\$9,278	\$18,069	\$18,462	\$14,957	\$18,717	\$15,488	\$15,220	\$16,069	\$15,360	\$15,257	\$187,501	\$175,000			
Totals	\$32,441	\$29,812	\$24,436	\$32,417	\$33,556	\$29,615	\$36,529	\$29,153	\$28,494	\$30,046	\$30,296	\$31,336	\$368,132				
Total Budgeted														\$325,000			
Grand	\$126,029	\$116,668	\$88,395	\$130,200	\$135,196	\$115,569	\$144,014	\$114,879	\$112,938	\$119,260	\$119,417	\$121,263	\$1,443,824	\$1,335,000			
2013-2014																	
SALES TAX COLLECTION REPORT																	
	July	August	September	October	November	December	January	February	March	April	May	June	Totals	Budgeted			
Art. 39	\$53,092	\$38,025	\$38,971	\$30,890	\$51,669	\$41,573	\$55,223	\$40,074	\$40,883	\$51,855	\$40,845	\$45,708	\$528,808	\$510,000			
Art.40	\$34,973	\$34,445	\$31,096	\$31,650	\$26,845	\$32,596	\$36,408	\$26,977	\$30,000	\$32,869	\$30,716	\$35,340	\$383,915	\$350,000			
Art. 42	\$12,264	\$9,051	\$12,634	\$7,734	\$11,604	\$9,849	\$12,618	\$9,463	\$9,589	\$11,955	\$9,637	\$10,706	\$127,104	\$120,000			
Art. 44	\$3	\$2	\$14	\$292	\$2	\$2	\$4	\$24	\$224	\$2	\$4	-\$9	\$564				
Totals	\$100,332	\$81,523	\$82,715	\$70,567	\$89,956	\$84,020	\$104,253	\$76,538	\$80,696	\$96,681	\$81,202	\$91,745	\$1,039,827				
Total budgeted														\$980,000			
SCHOOL CAPITAL RESERVE FUND																	
	July	August	September	October	November	December	January	February	March	April	May	June	Totals	Budgeted			
Art. 40																	
Art. 42																	
Totals	\$12,264	\$9,051	\$12,634	\$7,734	\$11,604	\$9,849	\$12,618	\$9,463	\$9,589	\$11,955	\$9,637	\$10,706	\$127,104				
Total Budgeted														\$120,000			
Grand	\$112,596	\$90,574	\$95,349	\$78,301	\$101,560	\$93,869	\$116,871	\$86,001	\$90,285	\$108,636	\$90,839	\$102,451	\$1,167,332	\$1,100,000			

TAMMIE KRAUSS, REGISTER OF DEEDS

Camden County, NC

7/1/2015 - 7/31/2015

NC Children's Trust Fund	\$35.00
NC Domestic Violence Fund	\$210.00
State Revenue Stamp	\$3,141.88
County Revenue Stamp	\$3,270.12
Land Transfer Fee	\$0.00
Floodplain Map Fund	\$0.00
Supplemental Retirement	\$63.02
ROD Automation Fund	\$372.31
Dept Of Cultural Resources	\$0.00
Vital Records Fund	\$0.00
State General Fund	\$0.00
State Treasurer Amount	\$551.80
ROD General Fund	\$2,973.27
Total Distribution For Period	\$10,617.40
Cash Total	\$771.80
Check Total	\$9,859.60
Pay Account Total	\$0.00
Overpayment Total	\$14.00
Total Deposit For Period	\$10,617.40
Total Escrow Change	\$0.00

Camden County Register of Deeds: Tammie Krauss
July 2015 Daily Deposit

DATE	NC CHILDRI TRUST	NC DOM. VIO. FUND	STATE REV. STAMPS	COUNTY REV. STAMPS	RETIREME	AUTO FUND	STATE TREASURY	ROD GENERAL	TOTAL
07/01/15	\$ -	\$ -	\$ 284.20	\$ 295.80	\$ 2.88	\$ 19.31	\$ 24.80	\$ 149.06	\$ 776.05
07/08/15	\$ 10.00	\$ 60.00	\$ -	\$ -	\$ 5.34	\$ 26.96	\$ 37.20	\$ 216.50	\$ 356.00
07/02/15	\$ -	\$ -	\$ 269.50	\$ 280.50	\$ 3.48	\$ 21.74	\$ 37.20	\$ 169.58	\$ 782.00
07/06/15	\$ -	\$ -	\$ -	\$ -	\$ 0.45	\$ 2.97	\$ -	\$ 26.58	\$ 30.00
07/07/15	\$ -	\$ -	\$ -	\$ -	\$ 2.37	\$ 15.03	\$ 18.60	\$ 122.25	\$ 158.25
07/09/15	\$ -	\$ -	\$ -	\$ -	\$ 2.17	\$ 13.69	\$ 18.60	\$ 110.09	\$ 144.55
07/10/15	\$ 5.00	\$ 30.00	\$ 199.92	\$ 208.08	\$ 5.94	\$ 35.76	\$ 49.60	\$ 269.70	\$ 804.00
07/13/15	\$ -	\$ -	\$ 186.20	\$ 193.80	\$ 6.59	\$ 39.11	\$ 68.20	\$ 325.60	\$ 819.50
07/14/15	\$ -	\$ -	\$ 318.50	\$ 331.50	\$ 3.15	\$ 19.51	\$ 24.80	\$ 162.64	\$ 860.10
07/15/15	\$ -	\$ -	\$ 191.59	\$ 199.41	\$ 2.49	\$ 12.63	\$ 37.20	\$ 113.68	\$ 557.00
07/16/15	\$ -	\$ -	\$ -	\$ -	\$ 0.11	\$ 0.75	\$ -	\$ 6.79	\$ 7.65
07/17/15	\$ 5.00	\$ 30.00	\$ 753.62	\$ 784.38	\$ 5.61	\$ 32.91	\$ 43.40	\$ 257.08	\$ 1,912.00
07/20/15	\$ -	\$ -	\$ -	\$ -	\$ 0.15	\$ 0.99	\$ -	\$ 8.86	\$ 10.00
07/21/15	\$ -	\$ -	\$ -	\$ -	\$ 1.23	\$ 8.14	\$ 12.40	\$ 60.23	\$ 82.00
07/22/15	\$ -	\$ -	\$ -	\$ -	\$ 1.56	\$ 7.76	\$ 24.80	\$ 69.88	\$ 104.00
07/23/15	\$ -	\$ -	\$ 135.24	\$ 140.76	\$ 1.23	\$ 8.14	\$ 12.40	\$ 60.23	\$ 358.00
07/24/15	\$ 5.00	\$ 30.00	\$ 366.03	\$ 380.97	\$ 5.95	\$ 35.79	\$ 49.60	\$ 269.96	\$ 1,143.30
07/27/15	\$ 5.00	\$ 30.00	\$ 215.60	\$ 224.40	\$ 2.43	\$ 12.53	\$ 12.40	\$ 99.64	\$ 602.00
07/28/15	\$ 5.00	\$ 30.00			\$ 1.35	\$ 5.38		\$ 48.27	\$ 90.00
07/29/15					\$ 1.89	\$ 13.11	\$ 6.20	\$ 104.80	\$ 126.00
07/30/15					\$ 0.39	\$ 1.94	\$ 6.20	\$ 17.47	\$ 26.00
07/31/15			\$ 221.48	\$ 230.52	\$ 6.26	\$ 38.16	\$ 68.20	\$ 304.38	\$ 869.00
									0.00
									\$ -
TOTAL	\$ 35.00	\$ 210.00	\$ 3,141.88	\$ 3,270.12	\$ 63.02	\$ 372.31	\$ 551.80	\$ 2,973.27	\$ 10,617.40

Camden County Register of Deeds: Tammie Krauss
August 2015 Daily Deposit

DATE	NC CHILDREN TRUST	NC DOM. VIO. FUND	STATE REV. STAMPS	COUNTY REV. STAMPS	RETIREMENT	AUTO FUND	STATE TREASURY	ROD GENERAL	TOTAL
08/03/15	\$ -	\$ -	\$ -	\$ -	\$ 0.69	\$ 3.92	\$ 6.20	\$ 35.19	\$ 46.00
08/05/15	\$ -	\$ -	\$ -	\$ -	\$ 1.86	\$ 11.69	\$ 18.60	\$ 92.15	\$ 124.30
08/06/15	\$ -	\$ -	\$ 431.69	\$ 449.31	\$ 3.78	\$ 23.09	\$ 43.40	\$ 181.73	\$ 1,133.00
08/07/15	\$ -	\$ -	\$ 896.70	\$ 933.30	\$ 7.65	\$ 50.56	\$ 62.00	\$ 389.79	\$ 2,340.00
08/10/15	\$ -	\$ -	\$ 312.62	\$ 325.38	\$ 5.38	\$ 32.38	\$ 55.80	\$ 265.14	\$ 996.70
08/11/15	\$ -	\$ -	\$ 197.96	\$ 206.04	\$ 0.39	\$ 1.94	\$ 6.20	\$ 17.47	\$ 430.00
08/12/15	\$ -	\$ -	\$ -	\$ -	\$ 5.07	\$ 34.11	\$ 31.00	\$ 267.82	\$ 338.00
08/13/15	\$ -	\$ -	\$ 490.00	\$ 510.00	\$ 5.88	\$ 39.49	\$ 43.40	\$ 303.23	\$ 1,392.00
08/14/15	\$ -	\$ -	\$ 445.90	\$ 464.10	\$ 4.02	\$ 25.29	\$ 37.20	\$ 201.49	\$ 1,178.00
08/17/15	\$ 5.00	\$ 30.00	\$ -	\$ -	\$ 4.51	\$ 26.19	\$ 24.80	\$ 209.50	\$ 300.00
08/18/15	\$ -	\$ -	\$ 127.89	\$ 133.11	\$ 2.79	\$ 15.90	\$ 37.20	\$ 130.11	\$ 447.00
08/19/15	\$ -	\$ -	\$ 237.16	\$ 246.84	\$ 3.92	\$ 23.95	\$ 31.00	\$ 202.13	\$ 745.00
08/20/15	\$ -	\$ -	\$ 245.00	\$ 255.00	\$ 5.34	\$ 33.39	\$ 55.80	\$ 261.47	\$ 856.00
08/21/15	\$ 5.00	\$ 30.00	\$ -	\$ -	\$ 2.67	\$ 14.11	\$ 12.40	\$ 113.82	\$ 178.00
08/24/15	\$ -	\$ -	\$ -	\$ -	\$ 2.48	\$ 16.34	\$ -	\$ 146.28	\$ 165.10
08/25/15	\$ -	\$ -	\$ 261.66	\$ 272.34	\$ 5.73	\$ 39.13	\$ 37.20	\$ 300.09	\$ 916.15
08/26/15	\$ -	\$ -	\$ 64.68	\$ 67.32	\$ 3.78	\$ 23.09	\$ 43.40	\$ 181.73	\$ 384.00
08/27/15	\$ -	\$ -	\$ 392.00	\$ 408.00	\$ 4.29	\$ 24.52	\$ 49.60	\$ 207.59	\$ 1,086.00
08/28/15			\$ 376.32	\$ 391.68	\$ 4.76	\$ 30.91	\$ 43.40	\$ 238.93	\$ 1,086.00
08/31/15			\$ 484.61	\$ 504.39	\$ 9.66	\$ 56.85	\$ 117.80	\$ 459.69	\$ 1,633.00
									\$ -
									0.00
									0.00
									\$ -
TOTAL	\$ 10.00	\$ 60.00	\$ 4,964.19	\$ 5,166.81	\$ 84.65	\$ 526.85	\$ 756.40	\$ 4,205.35	\$ 15,774.25

Pasquotank-Camden EMS Camden Response Times - July 2015

Call Date	Location	En Route	On Scene	Response Time
7/2/2015	1417 S 343 Hwy	10:33	10:48	0:15
	267 Ivy Neck Rd	16:38	16:43	0:05
	426 Old Swamp Rd	20:49	21:06	0:17
7/3/2015	140 Keeter Barn Rd	14:06	14:07	0:01
7/4/2015	191 W US 158 HWY	13:03	13:10	0:07
	315 Main Rd	20:47	20:55	0:08
7/5/2015	140 Keeter Barn Rd	13:06	13:13	0:07
	110 Cedar Branch Rd	15:37	15:52	0:15
7/7/2015	368 Lambs Rd	10:49	10:55	0:06
	476 North River Rd	16:32	16:44	0:12
	724 N Hwy 343	16:36	16:46	0:10
	158/Havenwood	19:13	19:18	0:05
	100 W US 158 Hwy	19:26	19:33	0:07
7/8/2015	217 Lamb's Rd	17:00	17:10	0:10
	300 Bridge Ct	19:38	19:42	0:04
7/9/2015	101 Park Dr	12:46	12:56	0:10
	154 Dock Landing Loop	18:15	18:21	0:06
7/11/2015	744 Sandy Hook Rd	7:38	7:57	0:19
	284 Lamb's Rd	16:21	16:27	0:06
7/13/2015	109 Bourbon St	13:02	13:06	0:04
7/14/2015	117 N 343	13:32	13:34	0:02
	217 N 343 Hwy	19:52	19:53	0:01
7/17/2015	Upton Rd/Seymour	9:14	9:17	0:03
7/20/2015	217 Lamb's Rd	10:57	11:03	0:06
	894 N 343 Hwy	21:02	21:13	0:11
7/23/2015	206 Maddrey Dr	8:53	8:59	0:06
	158 Country Club Road	18:31	18:36	0:05
7/24/2015	103 Camden Ave	15:54	16:07	0:13
	163 Upton Rd	19:57	20:01	0:04
7/25/2015	140 Keeter Barn Rd	14:09	14:10	0:01
7/27/2015	600 Main St	11:53	11:58	0:05
	230 Lilly Rd	13:03	13:08	0:05
	114 Long Pine Rd	14:14	14:17	0:03
	2871 US 17 Hwy	14:24	14:35	0:11
	315 Main Rd	16:50	16:56	0:06
	300 Bridge Ct	18:23	18:26	0:03
	104 Elliott Dr	19:50	20:05	0:15
7/28/2015	143 Pier Landing Loop	9:42	9:58	0:16
	744 Sandy Hook Rd	12:00	12:16	0:16
7/29/2015	379 Old Swamp Road	13:21	13:24	0:03
7/31/2015	102 McCoy Rd	9:19	9:26	0:07
	2362 US 17 Hwy	13:50	13:56	0:06
	214 Riverview Ave	16:52	17:02	0:10
Camden Average Response Times				0:07

Camden County Public Library August Statistics

- **Visitor Count:** 2,730
- **Days/Hours Open:** 26/286
- **# Items in Collection:** 12,060 (Opening Day Collection # Items = 4,755)
- **Total Check Outs/Renewals:** 3,674
- **Library Card Holders:** 2,253
- **Computer/ Wireless Use:** 1,122
- **Juvenile Programs :** 7 programs / 80 attendance
- **Adult Programs :** 1 program / 8 attendance
- **Meeting Room:** 3 reservations / 25 attendance

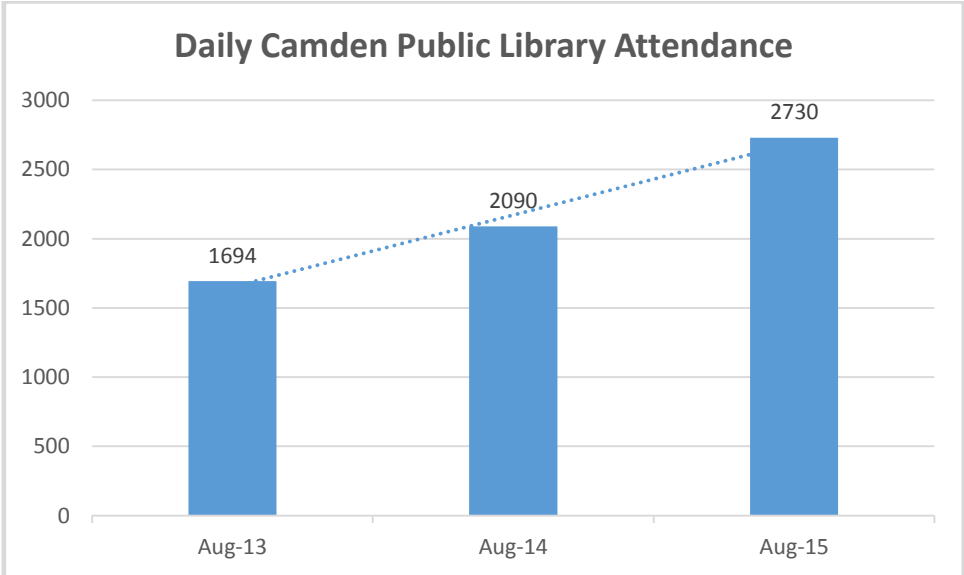

Daily attendance for the month of August, compared by year (2013-2015).

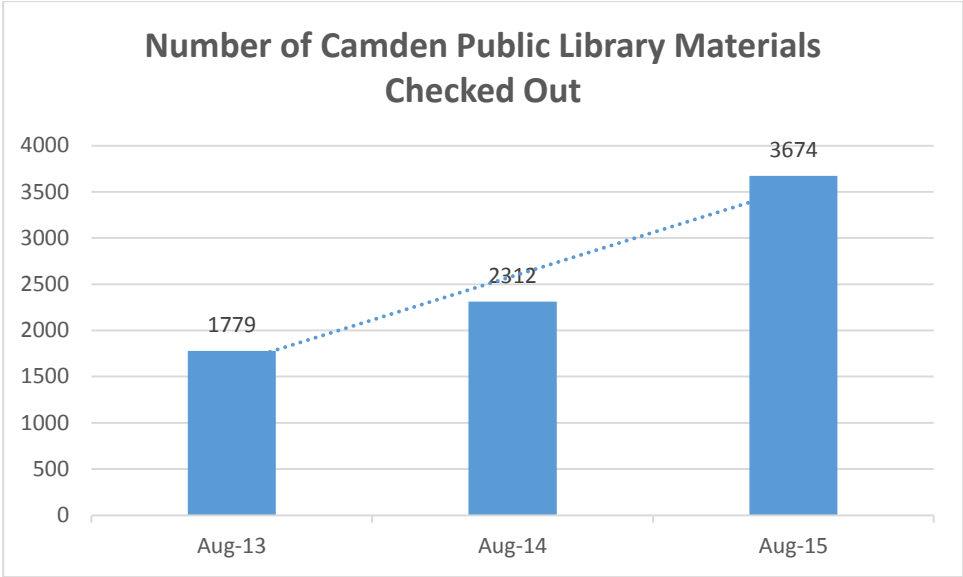

Number of library materials checked out in August, compared by year (2013-2015).

Pat McCrory, Governor
Andrew T. Heath, Chairman



Charlton L. Allen, Commissioner
Bernadine S. Ballance, Commissioner
Linda Cheatham, Commissioner
Danny Lee McDonald, Commissioner
Tammy R. Nance, Commissioner

North Carolina Industrial Commission

August 3, 2015

New Deputy Commissioners Appointed

FOR IMMEDIATE RELEASE

Raleigh, N.C. - North Carolina Industrial Commission Chairman Andrew T. Heath has announced the appointment of seven deputy commissioners. Chairman Heath has appointed Leigha Blackwell Sink and Jesse “Jay” Tillman and re-appointed current Deputy Commissioners Philip A. Baddour, III, J. Brad Donovan, James C. Gillen, Myra L. Griffin, and Adrian A. Phillips. All appointments are for six-year terms. Deputy commissioners function as the Industrial Commission’s trial-level judges and hold hearings in contested workers’ compensation cases, state tort claims, and other matters.

“Deputy commissioners play a significant role in protecting the rights of North Carolina’s workers and businesses,” said Chairman Heath. “I am very pleased to appoint this experienced and skilled group to hear and adjudicate the Commission’s diverse caseload.”

Leigha Blackwell Sink previously practiced workers’ compensation law with the firm of Gallivan, White & Boyd, P.A. in Charlotte, NC. Prior to her time in private practice, she served as an Assistant Attorney General for the South Carolina Attorney General’s Office, and clerked for South Carolina Circuit Court Judge Edgar W. Dickson. Ms. Sink is a graduate of the University of North Carolina, and earned her law degree from the University of South Carolina. Ms. Sink is admitted to practice law in both North Carolina and South Carolina.

Jesse “Jay” Tillman most recently practiced general civil litigation with The Bond Helping Law Group in Charlotte, NC. Previously, he spent ten years in both the Raleigh and Charlotte offices of Cranfill, Sumner, and Hartzog, LLP. Mr. Tillman is an officer in the United States Navy Reserve and recently served as Special Assistant and Operations Risk Management Officer to the Fifth Fleet Commander in Bahrain. He is a recipient of the Legion of Merit and Defense Meritorious Service Medal. Mr. Tillman is a graduate of the University of North Carolina, the Campbell University School of Law, and is admitted to practice law in both North Carolina and South Carolina.

Philip A. Baddour, III joined the Industrial Commission as a Deputy Commissioner in November 2000. From 1996 to 1999, Mr. Baddour practiced law in Goldsboro, primarily in the areas of personal injury and workers’ compensation. In 1999, he joined the North Carolina Attorney General’s Office as an Assistant Attorney General in the Tort Claims Section. As an Assistant Attorney General, he represented state agencies in workers’ compensation and tort claim actions. Before entering law school, he served as a Legislative Assistant to Congressman Martin Lancaster. Mr. Baddour is a graduate of the University of North Carolina, the Campbell University School of Law, and also serves as a First Lieutenant in the North Carolina National Guard.

J. Brad Donovan came to the Industrial Commission in 1997 as a Special Deputy Commissioner and was appointed a Deputy Commissioner in October 2003. Prior to that time, he spent two years as a clerk in the Raleigh law firm of Edmisten and Weaver, and eight years as a member of Staff Counsel to the North Carolina Court of Appeals. Mr. Donovan is a graduate of the University of Kansas and the North Carolina Central University School of Law. He has published law review articles in the areas of family law and appellate practice.

James C. Gillen has served as a Deputy Commissioner since May 2005. He previously served as a Special Deputy Commissioner as well as an Agency Legal Specialist for several former Commissioners. He is a graduate of North Carolina State University and the Campbell University School of Law.

Myra L. Griffin has served as a Deputy Commissioner since February 2005. Before her appointment as a Deputy Commissioner, Ms. Griffin worked as an Assistant Attorney General with the Tort Claims Section of the N.C. Department of Justice. In this capacity, she served as Agency Counsel to the Industrial Commission and prosecuted cases with the Fraud Investigations Unit. Ms. Griffin previously served the Commission as both an Agency Legal Specialist and Special Deputy Commissioner. She is a graduate of the University of North Carolina and the North Carolina Central University School of Law.

Adrian A. Phillips joined the Industrial Commission as a Deputy Commissioner in May 2002. Prior to her appointment, she worked as an Assistant Attorney General in the Tort Claims Section of the Department of Justice and she was assigned to the Industrial Commission as Agency Counsel. She served as Supervisor and Prosecutor of white-collar crime in the Medicaid Fraud Division from 1998-2000. Ms. Phillips also served as an Assistant District Attorney in Caswell and Person counties. She is a graduate of Bennett College and the North Carolina Central University School of Law.

Contact: Kim Genardo
Director of Communications
North Carolina Department of Commerce
(919) 733-3438

Angela Wooten

Subject: Commerce Department Launches Mobile App for Job Seekers

Release: Immediate
Date: August 18, 2015

Contact: David Rhoades
Phone: (919) 715-6556

Commerce Department Launches Mobile App for Job Seekers

Raleigh, N.C. – NCWorks Career Centers are now registering more job seekers on the new NCWorks mobile app to connect them to meaningful employment.

The mobile app allows users to apply for jobs, compare their skills to job requirements, find training opportunities, and learn more about a career or industry through wage and employment projections. In the mobile app, individuals search for jobs by keyword or circling a select area and all job postings within that circumference will be displayed.

“We want North Carolina’s job seekers to have access to the best jobs in the market,” said Will Collins, executive director of NCWorks. “By connecting people to jobs and training resources in their areas, we can help them get back on their feet and improve the lives of our communities.

The app also contains special features for veterans, who can review job postings up to 24 hours in advance of the general public and search for civilian careers using the Military Occupational Code.

Registration for NCWorks Online is free. The app is free to download for the [iPhone](#), [iPad](#) and [Android](#) devices. N.C. Commerce Workforce Solutions operates the NCWorks app.

About NCWorks Online

NCWorks Online is a free service that provides several benefits to job seekers and employers. Job seekers can search job posts pulled from thousands of websites and receive alerts through email and text message. Employers can post jobs to find the talent they need, as well as take advantage of real-time labor market information that will assist them in making competitive offers to recruit talented workers. For more information about NCWorks Online, visit www.neworks.gov.

For more information about the N.C. Commerce Workforce Solutions, visit www.nccommerce.com/workforce.

Angela Wooten

From: NC
Sent: Thursday, August 27, 2015 2:27 PM
To: info@camdencountync.gov
Subject: [Release] NCWorks Career Centers Give Free Food to Veterans

Pat McCrory, Governor

John E. Skvarla, III, Secretary



**NORTH CAROLINA
DEPARTMENT OF COMMERCE**

Release: Immediate
Date: August 19, 2015

Contact: David Rhoades
Phone: (919) 715-6556

NCWorks Career Centers Give Free Food to Veterans

RALEIGH – NCWorks Career Centers’ ongoing support for military veterans seeking employment takes a healthy turn thanks to a new partnership with The Produce Box, a local organization that sells and distributes fresh produce grown by North Carolina farmers.

[The Produce Box](#), located in Raleigh, turned to NC Commerce’s Workforce Solutions team for help after searching for unique ways the company could assist veterans. The two organizations agreed to provide complimentary boxes of fresh produce to out-of-work vets and their families through the state’s career centers, which already work closely with veterans [to help them find jobs and training programs](#).

“We’re working hard to make North Carolina the state of choice for vets, in ways both large and small,” said N.C. Commerce Secretary John E. Skvarla III. “While our main focus is to connect veterans with training programs and job opportunities, this gift from The Produce Box provides an additional helping hand.”

“We are so proud that our members support their communities through The Produce Box,” said Courtney Tellefsen, founder and chief executive officer of the Produce Box. “Donating our Hero Boxes to veterans was a new effort for us this year, and we were glad to give back to those who mean so much to our country.”

This month, 114 boxes of fresh produce were distributed to veterans through the career centers in Charlotte, Raleigh, Wilmington, and Winston-Salem.

CeJae Briscoe, a veteran of the U.S. Navy and Air Force, was one recipient of the distribution. Briscoe used the NCWorks Career Center in Raleigh to connect with a job opportunity at Volunteers for America. A single mother of two children, Briscoe recently accepted a full-time position—also a promotion—at Passage Home, one of the organization’s sister agencies.

“Had I never come here,” Briscoe said, referring to her career center, “I would have never known about either.”

“As a part of NCWorks, we are committed to improving the lives of our vets by helping to connect them to jobs and training after they’ve left the service,” said Will Collins, assistant secretary for workforce solutions. “These produce boxes are one of the many ways we can express our gratitude to the brave men and women who have served our country.”

NC Workforce Solutions is a part of the North Carolina Department of Commerce.

NCWorks

[The NCWorks initiative](#) includes the NC Commerce Division of Workforce Solutions, the NCWorks Commission, the NC Department of Public Instruction, and the North Carolina Community College System. The goal is to create a stronger alignment of services and resources to meet the workforce needs of businesses, connect North Carolinians to technical training and quality careers, and use data to monitor and assess program outcomes. For more information about NCWorks, visit www.nccommerce.com/networks.

For more information about NC Workforce Solutions, visit <http://nccommerce.com/workforce>.

###

David Rhoades

Deputy Communications Director
North Carolina Department of Commerce

919 715 6556 office
919 218 0542 mobile
drhoades@nccommerce.com

301 North Wilmington Street
4301 Mail Service Center
Raleigh, NC 27699-4301



Email correspondence to and from this address is subject to the North Carolina Public Records Law and may be disclosed to third parties.

You are currently subscribed to pressreleases as: info@camdencountync.gov.
You may [unsubscribe](#) to discontinue these mailings.

1 **Camden County Board of Commissioners**
2 **Regular Meeting**
3 **May 4th, 2015**
4 **7:00 P.M. - Regular Meeting**
5 **Historic Courtroom, Courthouse Complex**
6 **Camden, North Carolina**
7 **MINUTES**

8
9 The regular meeting of the Camden County Board of Commissioners was held
10 on May 4th, 2015 in the Historic Courtroom, Camden, North Carolina. The
11 following Commissioners were present:

12
13 Chairman Michael McLain, Vice Chair Sandra Duckwall,
14 Commissioners Garry Meiggs, Clayton Riggs and Tom White;

15
16 Also attending were County Finance Officer Stephanie Humphries, County
17 Attorney John Morrison and Clerk to the Board Angela Wooten. Present for
18 purposes of making a presentation(s) or providing supporting information for
19 agenda items were the following persons: Planning Director Dan Porter, Tax
20 Administrator Lisa Anderson.

21
22
23 **Regular Session, 7:00 P.M.**

24
25 Chairman Michael McLain called to order the May 4th, 2015 meeting of the
26 Camden County Board of Commissioners at 7:00 PM.

27
28
29 **Invocation and Pledge of Allegiance**

30
31 Commissioner Sandra Duckwall gave the invocation and led those present in the
32 Pledge of Allegiance.

33
34
35 **Public Comments**

36
37 None

40 **Consideration of Agenda**

41

42 Chairman Michael McLain asked if there were any changes to the agenda. Not
43 hearing any changes, Chairman Michael McLain called for a motion.

44

45 Commissioner Garry Meiggs made a motion to approve the agenda as presented.
46 The motion passed 5-0 with Chairman McLain, Vice Chair Sandra Duckwall,
47 Commissioners Garry Meiggs, Clayton Riggs and Tom White voting aye; no
48 Commissioner voting no; no Commissioner absent; and no Commissioner not
49 voting.

50

51

52 **Presentations**

53

54 ***Item 3.A - Keith Hamm, BA, QP Mobile Crisis Supervisor***

55

56 Keith Hamm, Mobile Crisis Supervisor for the Albemarle Area gave a brief
57 overview of the Mobile Crisis Program and how it has impacted the lives of
58 several Camden Citizen in 2014.

59

60 Integrated Family Services PLLC Mobile Crisis Management is a service available
61 24 hours a day/365 days per year at no cost to the individual receiving the service.
62 Our Mobile Crisis Team is endorsed by East Carolina Behavioral Health (ECBH)
63 to provide this service in Northeastern NC including Camden.

64

65 Mobile crisis responds to individuals in the community in an effort to deescalate
66 their crisis, develop appropriate strategies for symptom reduction, and make
67 linkages to services designed to prevent future crisis situations. This service
68 responds to crisis situations involving mental health, substance abuse, and
69 individuals who are developmentally delayed.

70

71 In 2014, IPS Mobile Crisis responded to 30 individuals in Camden County and
72 83% were diverted from inpatient care and incarceration. Of those individuals, 5
73 requests came from Law Enforcement. Additionally, 7 clients were referred
74 directly from schools in Camden County.

75

76

77

78

79

80 Public Hearings

81

82 *Item 4.A - Ordinance 2015-04-01 Rezoning Application (UDO 2015-03-11)*
83 *Harbinger Land & Timber LLC and Assorted Development Corp – Gary Dunston*

84

85 Commissioner Sandra Duckwall made a motion to go into public hearing for
86 Ordinance No. 2015-04-01 Rezoning Application (UDO 2015-03-11) Harbinger
87 Land & Timber LLC and Assorted Development Corp – Gary Dunston. The
88 motion passed 5-0 with Chairman McLain, Vice Chair Sandra Duckwall,
89 Commissioners Garry Meiggs, Clayton Riggs and Tom White voting aye; no
90 Commissioner voting no; no Commissioner absent; and no Commissioner not
91 voting.

92

93 Planning Director Dan Porter, advised the board Mr. Gary Dunstan owner/part
94 owner of both properties has applied to rezone approximately 41 (farmland) of
95 the 50 plus acres from Basic Residential (R3-2) to Basic Residential (R3-1).
96 Property located at the intersections of Sandy Lane, Keeter Barn and Sharon
97 Church Roads in South Mills Township. Staff presented the rezoning to the
98 Planning Board on April 15, 2015 with the applicant present and after discussion
99 Planning Board made the following motions:

- 100 1. Consistency Statement: Approved a motion that the application for rezoning
101 was consistent with both the CAMA Land Use Plan and Comprehensive Plan
102 as both allowed densities of 1 acre lots.
- 103 2. Motion was made and approved to rezone the 41 acres (farmland) from Basic
104 Residential (R3-2) to Basic Residential (R3-1).

105

106 Chairman Michael McLain asked if there were any comments from members of
107 the public that wish to come forward.

108

109 Larry Hewitt of Sharon Church Road in South Mills states that he and his wife
110 chose their 9 acre lot because it has been a dream of theirs to live in the country.
111 He would not like to rezone the development to 1 acre lots.

112

113 Mark Bissell advises that there are many benefits of having one acre lots allow
114 them to build a higher level of design with all housing frontages on interior
115 streets. He also mentions that there will be no driveways or mail boxes on the
116 state roads. The entire woodland area can be either preserved or turned into a
117 park. He believes the county will like the development. He then asks if there are
118 any questions from the board.

119

120 Vice Chair Sandra Duckwall asked how many houses would be built on the 41
121 acres.

122

123 Mr. Bissell replied it would be in the low 40's.

124

125 Commissioner Tom White requested information with regard to size of the
126 proposed homes when built on 1 acre lots.

127

128 Gary Dunston of Kitty Hawk is one of the developers and advised they are
129 proposing to 2000sq/ft. – 2500sq/ft. homes in the \$300,000 range.

130

131 Chairman Michael McLain asked if there were any further comments from the
132 public regarding this issue. Hearing none, he advised that the board would vote
133 at the next regular meeting due to opposition heard during the public Hearing.

134

135 Commissioner Tom White made a motion to close the public hearing. The
136 motion passed 5-0 with Chairman McLain, Vice Chair Sandra Duckwall,
137 Commissioners Garry Meiggs, Clayton Riggs and Tom White voting aye; no
138 Commissioner voting no; no Commissioner absent; and no Commissioner not
139 voting.

140

141

142 **Board Appointments**

143

144 ***Item 5.A - Economic Improvement Council***

145

146 Chairman McLain informed the board that the Economic Improvement Council
147 is looking for a volunteer to replace Camden's current representative. Clerk to
148 the Board Ms. Wooten confirms that currently the county does not have any
149 volunteer applications on file for the Economic Development Commission and
150 that Commission meets every other month..

151

152 Chairman Michael McLain requests that anyone interested in serving on the
153 Economic Development Commission should completed a Volunteer Application
154 and submit it to the County Managers office. Once there is a willing volunteer on
155 file, he will request this appointment be added to the agenda for the following
156 regular meeting.

157

158

159

CAMDEN COUNTY BOARD OF COMMISSIONERS
 Regular Meeting – May 4th, 2015

160 **Consent Agenda**

161

162 Commissioner Clayton Riggs made a motion to approve the consent agenda as
 163 presented. The motion passed 5-0 with Chairman McLain, Vice Chair Sandra
 164 Duckwall, Commissioners Garry Meiggs, Clayton Riggs and Tom White voting
 165 aye; no Commissioner voting no; no Commissioner absent; and no Commissioner
 166 not voting.

167

168

169 *Item 6.A - Draft Minutes –March 2nd, 2015*

170

171

172 *Item 6.B - Budget Amendments – BA022*

173

Section 1. To amend the General Fund as follows:

ACCT NUMBER	DESCRIPTION OF ACCT	AMOUNT	
		INCREASE	DECREASE
10-380470-434120	Clawback Refund	\$59,994.00	
104700-504300	Clawback	\$59,994.00	

This Budget Amendment is made to payback NC Dept of Commerce for clawback provision in grant.

This will result in a decrease of \$0 in the Contingency of the General Fund.

Balance in Contingency \$25,500.00

174

175

176

177 *Item 6.C - School Budget Amendments*

178

Code Number	Description of Code	Amount	
		Increase	Decrease
5100	Regular Instructional Programs	2,643.83	
5200	Special Instructional Programs		33,558.00
5800	School Based Support Services	39,910.00	
6100	Support & Development Serv.		773.00
6400	Technology Support Services		333.00
6600	Financial & Human Res Serv.	1,120.00	
6900	Policy, Ldrshp, & Pub Relations		8,496.00
7200	Child Nutrition Services	2,130.00	
Explanation: Funds received from USCG Jr. Leadership Program			
Total Appropriation in Current Budget		\$	1,467,278.00
Amount of Increase/Decrease of Above Amendment			2,643.83
Total Appropriation in Current Amended Budget		\$	1,469,921.83

CAMDEN COUNTY BOARD OF COMMISSIONERS
 Regular Meeting – May 4th, 2015

8. Other Local Current Expense Fund

A. We have received our allotment for the 2014-15 USCG Junior Leadership Program and must increase our budget to reflect additional funds received. We request your approval of the following amendment.

<u>USCG Jr. Leadership Program</u>		
5110.301.123	Salary – Instructor	\$ + 2,643.83
Total – USCG Jr. Leadership Program		\$ + 2,643.83
		=====
8.3590.301	Revenue – USCG Jr. Leadership Prog.	\$ - 2,643.83
		=====

B. We have reviewed this area of the budget and must transfer funds to cover costs of supplies and equipment within the program area. We request your approval of the following amendment.

<u>Carol M. White PEP Grant</u>		
5113.332.411	Supplies & Materials	\$ + 18,000.00
5113.332.541	Purchase of Equipment	- 18,000.00
Total – Carol M White PEP Grant		\$ + 0.00

C. We have reviewed this program area and find that we must transfer funds within the budget to cover contracted services and workshop expenses. We request your approval of the following amendment.

<u>Maintenance of Plant</u>		
6580.802.311...50	Contracted Services	\$ + 7,795.00
6580.802.422...50	Repair Parts, Materials, Labor	- 7,795.00
Total – Maintenance of Plant		\$ + .00

D. We have reviewed this area of the budget and must transfer funds within the budgeted areas to cover contracted services for our students with special needs. We request your approval of the following amendment.

<u>Children with Special Needs</u>		
5210.849.311	Contracted Services	- 33,558.00
5840.849.311	Contracted Services	+ 33,558.00

Other Local Current Expense Fund
 Budget Amendment
 April 16, 2015, Page 2

Total – Children with Special Needs	\$ + .00
-------------------------------------	----------

E. We have reviewed this program area and find that we must transfer funds to cover the cost of contracted services for the policy manual work being done. We request your approval of the following amendment.

<u>Board of Education</u>		
6910.860.192	Salary – BOE Member	\$ - 8,300.00
6910.860.311	Contracted Services	+ 8,300.00
Total – Board of Education		\$ + .00

F. We have reviewed this area of the budget and must transfer funds within the budgeted areas to cover expenses. We request your approval of the following amendment.

<u>School Technology</u>		
5110.905.311	Contracted Services	\$ - 1,557.00
5110.905.418	Comp Software & Supplies	- 1,000.00
5110.905.462	Pur of Non-Cap Comp Hdwe	+ 2,557.00
5860.905.418	Comp Software & Supplies	+ 481.00
5860.905.462	Pur of Non-Cap Comp Hdwe	+ 5,871.00
6110.905.422	Repair Parts & Materials	- 773.00
6400.905.341	Telephone – Telecom	- 418.00
6400.905.462	Pur of Non-Cap Comp Hdwe	+ 85.00
6610.905.462	Pur of Non-Cap Comp Hdwe	+ 1,120.00
6940.905.319	Other Prof & Tech Services	- 2,500.00
6940.905.341	Telephone – Telecom (CO)	- 3,000.00
6940.905.462	Pur of Non-Cap Comp Hdwe	- 2,996.00
7200.905.418	Comp Software & Supplies	+ 310.00
7200.905.462	Pur of Non-Cap Comp Hdwe	+ 1,820.00
Total – School Technology		\$ + .00

179
 180
 181
 182
 183
 184
 185
 186
 187
 188
 189

CAMDEN COUNTY BOARD OF COMMISSIONERS
 Regular Meeting – May 4th, 2015

190 **Item 6.D - Expenditure Request**

191

192 The Camden Volunteer Fire Department is requesting funds for needed
 193 equipment.
 194

DATE: 04/21/15
 INVOICE: 006153
 CUSTOMER PO#: Morgan

SOLE TO: CAMDEN FIRE DEPARTMENT
 ATTENTION: G. A. Cortright/Wesley Morgan
 483 North NC Highway 8343
 Camden, NC 27821

DELIVERED TO: FIRE STATION

**Itemize Equipment on the following sheets of information and pricing
 in the department's accounts as shown:-----**

\$	\$ 24,887.75
Labour/Transit as Shown w/ Discounts	412.20
	97.20
	28.20
Service/Maintenance	900.00
Total	\$ 26,125.35
NC Sales Tax	1,100.89
County Taxes	900.21
Shipping from Manufacturer	88.57
Total Due	\$ 28,214.99

195

196

197

198 **Item 6.E - Tax Refunds, Pickups, & Releases**

199

REFUNDS OVER \$100.00

North Carolina Vehicle Tax System

NCVTS Pending Refund report

Plate No	Address	Agency	Vehicle	Class	Rate	Amount	Amount	Amount	Amount	Amount	Amount	Amount	Amount	Amount	Amount	Amount	Amount	Amount
WV00	70 BOX 130	CAMDEN, NC	2011	2011	2011	2011	2011	2011	2011	2011	2011	2011	2011	2011	2011	2011	2011	2011
WV00	70 BOX 130	CAMDEN, NC	2011	2011	2011	2011	2011	2011	2011	2011	2011	2011	2011	2011	2011	2011	2011	2011
WV00	70 BOX 130	CAMDEN, NC	2011	2011	2011	2011	2011	2011	2011	2011	2011	2011	2011	2011	2011	2011	2011	2011
WV00	70 BOX 130	CAMDEN, NC	2011	2011	2011	2011	2011	2011	2011	2011	2011	2011	2011	2011	2011	2011	2011	2011

REFUNDS OVER \$100.00

Refunds to Be Issued by Finance Office

Refund	Amount	Vehicle	Plate	Year	Reason
389.28	389.28	2011	WV00	2011	Should have been defraxed
389.28	389.28	2011	WV00	2011	Should have been defraxed
389.28	389.28	2011	WV00	2011	Should have been defraxed
389.28	389.28	2011	WV00	2011	Should have been defraxed
1,597.08	1,597.08	TOTAL Refunds			

200

201

202

203

204

205

CAMDEN COUNTY BOARD OF COMMISSIONERS
Regular Meeting – May 4th, 2015

206 **Item 6.F - Expenditure Request**

207

208 The Camden Volunteer Fire Department is requesting to borrow funds for new
209 Fire Truck. Propose 1% interest to avoid market rates and still provide interest to
210 county for loss of interest on cash from bank and a repayment plan of \$100,000
211 per year over 5 years.

212

INVOICE

	Sutphen Corporation PO Box 158 Arlin, OH 43002 Tel 614.889.1005 800.548.5860 Fax 614.889.0874 www.sutphen.com	PLEASE REMIT TO: Sutphen Corporation PO box 631803 Cincinnati, OH 45263-1803	DATE: 04/28/15	NUMBER: HS-0612-02
---	--	--	--------------------------	------------------------------

SOLD TO: County of Camden
317 N. Highway 343
Camden, NC 27921

ORDER NO: HS 5612	DATE: 10/21/14	CUSTOMER'S PO #: 166-00	SALES REP: JS	PREPARED BY: SI	TERMS: Payable in 30 DAYS
-----------------------------	--------------------------	-----------------------------------	-------------------------	---------------------------	-------------------------------------

ITEM / DESCRIPTION:	AMOUNT:
One Sutphen Custom Tanker	\$ 544,467.89
Less Down Payment Received on 11/10/14	\$ (75,000.00)
TOTAL AMOUNT DUE	\$ 469,467.89

213

214

215

216 **Item 6.G - Volunteer Form - CEDC**

217

Application for Citizen Service - Volunteer Form

If you are a citizen of Camden County and would like to serve on one of the County's boards or commissions, please complete this application and return it to the County Manager's Office, 330 East HWY 158, mail to P.O. Box 180, Camden, North Carolina 27921 or e-mail cmcc@camdencc.gov

Name Christopher Purcell

Mailing Address 116 Billets Bridge Rd Camden NC 27921

Township you live in: Courthouse

Telephone (home) 757-651-5448 (business) 252-337-4111

Email address: chris.purcell@firehousesubs.com

Are you a registered voter? Yes No

Have you ever been convicted of a felony? Yes No

Please identify any talent, interest, skill, experience or educational preparation which might be helpful to a board or commission:
Business Owner
Chair-Billets RC Area Chamber of Commerce
Chairman EC Chamber Legislative Committee

Board or Commissions upon which you are interested in serving: (List on opposite side)
Camden Economic Development Commission

As a member of a Board or Commission, you will be expected to attend at least 75% of the meetings. Please note the by-laws of some Boards and Commissions limit the number of terms served. This application is a notification of your interest to serve on a Board or Commission to be considered by the Board of Commissioners when a vacancy occurs. Thanks for your interest in Camden County Government.

Signature  Date 04-17-2015

218

CAMDEN COUNTY BOARD OF COMMISSIONERS
Regular Meeting – May 4th, 2015

219 **Item 6.H - Consortium Agreement Resolution**
220

RESOLUTION No. 2015-05-01
APPROVING NORTHEASTERN WORKFORCE DEVELOPMENT CONSORTIUM
AGREEMENT

WHEREAS, the counties of Camden, Cherokee, Clatsack, Dare, Gates, Hyde, Pasquotank, Perquimans, Tyrrell and Washington, being independent and contiguous units of local county government (the "Counties"), wish to agree to establish a workforce development consortium ("Consortium") to act jointly as a Local Workforce Development Area under the Workforce Innovation and Opportunity Act (WIOA), Public Law 113-128 as enacted July 22, 2014; and

WHEREAS, in addition to specific authority to enter into the agreement attached hereto, a "County Appointed Representative" for WIOA purposes upon whose representation the State, the Workforce Development Board, the Albemarle Commission (as the local administrative/fiscal agent) and the other Counties may rely, must be designated and authorized to execute the attached agreement and such other agreements as are necessary for purposes of WIOA and who shall sit on the Consortium Board;

BE IT RESOLVED THAT: Chairman Michael McLain, is hereby designated the "County Appointed Representative" for the foregoing purposes and so such he/she is fully authorized to execute the attached agreement and such other and further agreements on behalf of this County as are necessary for these purposes.

ADOPTED, by the Camden County Board of Commissioners on this 4th day of May, 2015.

221
222
223
224 **Item 6.I - 2015 National Day of Prayer**
225

NATIONAL DAY OF PRAYER
MAY 7th, 2015
A PROCLAMATION BY THE CAMDEN COUNTY BOARD OF COMMISSIONERS

WHEREAS, because of the faith of our many founding fathers, public prayer and national days of prayer have a longspanning and significant history in American tradition; and

WHEREAS, since the first call to prayer in 1773, when the Continental Congress asked colonies to pray for wisdom in forming a nation, the call to prayer has continued through our history; and

WHEREAS, in 1986 legislation adopting the first Thursday in May of each year as National Day of Prayer was passed unanimously by both Houses of Congress and signed by President Ronald Reagan; and

WHEREAS, the National Day of Prayer belongs to all Americans and it is a day that transcends differences, bringing together citizens from all backgrounds and all faiths to join in united prayer to acknowledge our dependence on God, to give thanks for blessings received, to request healing for wounds endured, and to ask God to guide our leaders and bring wisdom to the United States and her citizens; and

WHEREAS, the 64th Annual National Day of Prayer will take place on Thursday, May 7, 2015 where millions will unite in prayer at thousands of events from coast to coast; and

WHEREAS, the theme for 2015 is LORD, HEAR OUR CRY, emphasizing the need for individuals, corporate and individually, to place their faith in the unfailing character of their Creator, who is sovereign over all governments, authorities and men, and was inspired by 1 Kings 8:26: "Hear the cry and the prayer that your servant is praying to your presence daily;" and

WHEREAS, it is fitting and proper to give thanks to God by observing a day of prayer in Transylvania County when all may acknowledge our blessings and express gratitude for them, while recognizing the need for strengthening religious and moral values in our State and Nation.

NOW, THEREFORE, The Camden County Board of Commissioners does hereby proclaim May 7th, 2015 to be designated as "A DAY OF PRAYER IN CAMDEN COUNTY" and encourages the citizens of Camden County to observe ways appropriate to its importance and significance.

Adopted this the 4th day of May, 2015.

ATTEST:

Angela Weston - Clerk to the Board

E. Michael McLain - Chairman

P. O. Box 1303 • 130 East Hwy. 150 • Camden, NC 27513 • Phone: (252) 338-6163 • Fax: (252) 333-7811
www.camdencountync.gov

226
227
228
229
230
231

CAMDEN COUNTY BOARD OF COMMISSIONERS
Regular Meeting – May 4th, 2015

232 **Item 6J - Older Americans Month 2015**
233

OLDER AMERICANS MONTH 2015

A PROCLAMATION BY THE CAMDEN COUNTY BOARD OF COMMISSIONERS

Whereas, Camden County, NC includes a thriving community of older Americans who deserve recognition for their contributions and sacrifices to ensure a better life for future generations; and

Whereas, The Camden County Board of Commissioners is committed to helping all individuals live longer, healthier lives at the communities of their choice for as long as possible; and

Whereas, since 1963, the Older Americans Act has provided services that help older adults remain healthy and independent by complementing existing medical and health care systems, helping prevent hospital readmissions, and supporting some of life's most basic functions, such as bathing or preparing meals; and

Whereas, these programs also support family caregivers, address issues of exploitation, neglect and abuse of older adults, and adapt services to the needs of Native American elders; and

Whereas, we recognize the value of community engagement and service in helping older adults remain healthy and active while giving back to others; and

Whereas, our community can provide opportunities to enrich the lives of individuals of all ages by:

- Promoting and engaging in activity, wellness, and social inclusion.
- Emphasizing home- and community-based services that support independent living.
- Ensuring community members of all ages benefit from the contributions and experience of older adults.

Now therefore, The Camden County Board of Commissioners does hereby proclaim May 2015 to be Older Americans Month and urge every resident to take time this month to celebrate older adults and the people who serve and support them as powerful and vital individuals who greatly contribute to the community.

Adopted this the 4th day of May, 2015.

ATTEST:

Angela Wooten - Clerk to the Board



P. Michael McLain - Chairman

234
235
236 **New Business**

237
238 **Item 7.A - Monthly Tax Report**

239
240 Tax Administrator Lisa Anderson presented the Monthly Tax Report for March
241 2015.
242

**MONTHLY REPORT OF THE TAX ADMINISTRATOR TO THE
CAMDEN COUNTY BOARD OF COMMISSIONERS**

OUTSTANDING TAX DELINQUENCIES BY YEAR

YEAR	REAL PROPERTY	PERSONAL PROPERTY
2014	355,846.64	12,284.33
2013	104,042.04	10,995.48
2012	37,785.87	13,428.28
2011	20,848.32	10,871.28
2010	20,741.09	6,430.54
2009	7,442.87	6,069.27
2008	6,133.35	6,354.62
2007	6,133.10	9,822.26
2006	2,119.08	14,493.82
2005	1,690.71	26,536.96

CAMDEN COUNTY BOARD OF COMMISSIONERS
Regular Meeting – May 4th, 2015

TOTAL REAL PROPERTY TAX UNCOLLECTED	542,781.02
TOTAL PERSONAL PROPERTY UNCOLLECTED	117,286.84
TEN YEAR PERCENTAGE COLLECTION RATE	99.00%
COLLECTION FOR 2015 vs. 2014	75,523.93 vs. 94,189.66

LAST 3 YEARS PERCENTAGE COLLECTION RATE

2014	94.58%
2013	98.36%
2012	99.28%

THIRTY LARGEST UNPAID ACCOUNTS

SEE ATTACHMENT "A"

THIRTY OLDEST UNPAID ACCOUNTS

SEE ATTACHMENT "B"

EFFORTS AT COLLECTION IN THE LAST 30 DAYS

ENDING March 2015

BY TAX ADMINISTRATOR

<u>678</u>	NUMBER DELINQUENCY NOTICES SENT
<u>22</u>	FOLLOWUP REQUESTS FOR PAYMENT SENT
<u>2</u>	NUMBER OF WAGE GARNISHMENTS ISSUED
<u>13</u>	NUMBER OF BANK GARNISHMENTS ISSUED
<u>18</u>	NUMBER OF PERSONAL PHONE CALLS MADE BY TAX ADMINISTRATOR TO DELINQUENT TAXPAYER
<u>0</u>	NUMBER OF PERSONAL VISITS CONDUCTED (COUNTY OFFICES)
<u>14</u>	PAYMENT AGREEMENTS PREPARED UNDER AUTHORITY OF TAX ADMINISTRATOR
<u>0</u>	NUMBER OF PAYMENT AGREEMENTS RECOMMENDED TO COUNTY ATTORNEY
<u>0</u>	NUMBER OF CASES TURNED OVER TO COUNTY ATTORNEY FOR COLLECTION (I.D. AND STATUS)
<u>0</u>	REQUEST FOR EXECUTION FILES WITH CLERK OF COURTS
<u>0</u>	NUMBER OF JUDGMENTS FILED

CAMDEN COUNTY BOARD OF COMMISSIONERS
Regular Meeting – May 4th, 2015

Top 30 Unpaid

Roll	Parcel Number	Unpaid Amount	YrAdq	Taxpayer Name	City	Property Address
R	01-7980-00-17-0129.0000	23,393.24	1	CAMDEN SQUARE ASSOCIATES	SOUTH MILLS	
R	03-8971-00-12-0477.0000	18,387.07	1	GILBERT WAYNE OVERTON &	SHILOH	187 THOMAS POINT RD
R	01-7979-00-61-7389.0000	13,979.14	1	POTOMAC TIMBER INVESTMENTS #17	SOUTH MILLS	HORSHOE RD
R	01-7989-00-01-1714.0000	9,660.86	1	CHARLES MILLER HEIRS	SOUTH MILLS	HORSHOE RD
W	02-8923-00-19-3774.0000	6,070.52	1	HARTBREAD VENTURE PARTNERS, LLC	CAMDEN	431 158 US W
R	02-8944-00-31-2148.0000	7,239.15	1	CARL HARRINGTON	CAMDEN	150 SAND HILLS RD
R	03-8899-00-45-2682.0000	7,095.06	1	SEAMARK INC.	SHILOH	HOLLY RD
R	02-8924-01-17-4798.0000	7,030.98	1	LARRY G. LAMB SR	CAMDEN	152 158 US W
R	01-7990-01-08-8621.0000	6,199.91	2	WILLIE L. TURNER ETAL	SOUTH MILLS	1289 343 HWY N
R	03-8961-00-58-4506.0000	5,953.06	1	WARREN DEAN RIGGS	SHILOH	110 DRIFTWOOD DR
R	03-8972-00-51-8423.0000	5,904.26	1	BRITTON OVERTON	SHILOH	103 WESLEY RD
R	02-8948-00-84-1099.0000	5,709.89	1	GERTIE LEE & JUANOLA T BOUNTREE	CAMDEN	263 BELCHER RD
R	02-8944-00-87-4715.0000	5,430.92	1	MARK M. BRIGMAN SR & LISA L.	CAMDEN	175 MCKIMMEY RD
R	03-8943-04-74-3506.0000	5,428.11	1	ELLIOTT & DONNA JACOBS	SHILOH	117 SUNSET AVE
R	03-8943-00-81-9832.0000	4,752.99	1	MARLEA S. CECIL HEIRS	SHILOH	113 TROTMAN RD
R	01-8000-00-36-9596.0000	5,160.52	1	EULA B. GOVNER	SOUTH MILLS	TROTTERS WAY
R	02-8934-01-18-6001.0000	4,988.61	1	LINDA SUE LAMB HINTON	CAMDEN	150 158 US W
R	02-8945-00-41-2060.0000	4,408.88	1	LABELLE ETHERIDGE SR.	CAMDEN	168 BUSHELL RD
R	03-8950-00-08-7981.0000	4,066.47	1	JAMES E RHODES	SHILOH	111 CATALAN DR
R	03-8952-01-39-6259.0000	3,993.12	1	CHARLES RAY SAWYER	SHILOH	156 WALSTON LN
R	03-8943-04-83-8536.0000	3,973.23	1	JONES FAMILY CHILDRENS TRUST	SHILOH	125 CAMDEN AVE
R	03-8949-00-48-0800.0000	3,363.73	1	HECTOR C. DALALAY & MILAGROS O	SHILOH	113 SAILBOAT RD
R	02-8955-00-26-8902.0000	3,622.40	1	KIMBERLY S MITTA	CAMDEN	290 NORTH RIVER RD
R	03-8952-01-49-1090.0000	3,621.40	1	DRAZMA INC & SIMSON BAAI,LLC	SHILOH	343 HWY 3
R	02-8943-01-26-1507.0000	3,587.53	1	ROBERT L & MARY C. WELSH	CAMDEN	109 CANAL ST
R	02-8958-00-21-4428.0000	3,581.32	2	CAROLYN MCDANIEL	CAMDEN	SCOTLAND RD
R	02-8935-04-63-0820.0000	3,573.13	1	BELCROSS PROPERTIES, LLC	CAMDEN	197 158 US E
R	01-7980-00-62-1977.0000	3,495.60	8	SANDERS CROSSING OF CAMDEN CO	SOUTH MILLS	117 OTHERS PL
R	03-8951-00-22-3033.0000	3,371.23	1	RICKY'S WELDING, INC.	SHILOH	RICKS WA
R	03-8956-00-44-7928.0000	3,344.89	1	WIRLON & KATHLEEN MCCULLEN	SHILOH	404 SANDY HOOK RD

Top 30 Oldest

Roll	Parcel Number	Unpaid Amount	YrAdq	Taxpayer Name	City	Property Address
R	03-8899-00-45-2682.0000	7,095.06	10	SEAMARK INC.	SHILOH	HOLLY RD
R	01-7998-01-08-8621.0000	6,199.91	10	WILLIE L. TURNER ETAL	SOUTH MILLS	1289 343 NC N
R	02-8944-04-93-6214.0000	2,287.69	10	LEAH BARCO	SHILOH	148 CAMDEN AVE
R	01-7999-00-32-3810.0000	1,928.53	10	AUDREY TILLET	SOUTH MILLS	195 BUNKER HILL RD
R	03-8952-00-55-8737.0000	1,908.85	10	JOE GRIFFIN HEIRS	SHILOH	171 NECK RD
R	01-7999-00-60-8952.0000	982.62	10	MADE MCKENNA	SOUTH MILLS	117 GRIFFIN RD
R	02-8958-00-21-4428.0000	3,581.32	10	BERNICE FUCH	CAMDEN	113 BOURBON ST
R	02-8945-00-24-7426.0000	280.40	10	MICHAEL ORER	SHILOH	CENTERSIDE RD
R	03-8909-00-48-1097.0000	255.08	10	JOHN L. SAWYER HEIRS	SOUTH MILL	OLD SWAMP RD
R	03-8980-00-61-1968.0000	255.08	10	WILLIAMSBURG VACATION	SHILOH	CAMDEN POINT RD
R	03-8909-00-17-2462.0000	141.61	10	TODD ALLEN RIGGS	SHILOH	LITTLE CREEK RD
R	02-8945-00-41-2060.0000	4,408.88	9	LABELLE ETHERIDGE SR.	CAMDEN	168 BUSHELL RD
R	01-7989-00-01-1754.0000	3,495.60	9	SANDERS CROSSING OF CAMDEN CO	SOUTH MILLS	117 OTHERS PL
R	01-7989-00-04-60-1984.0000	1,129.11	9	CHRISTINE BIDDICK	SOUTH MILLS	105 BLOODFIELD RD
R	03-8899-00-37-0046.0000	1,622.23	9	ELIZABETH LONG	SHILOH	HORSHOE RD
R	01-7989-00-01-1754.0000	3,495.60	9	SANDERS CROSSING OF CAMDEN CO	SOUTH MILLS	117 OTHERS PL
R	01-7989-00-04-60-1984.0000	1,129.11	9	CHRISTINE BIDDICK	SOUTH MILLS	105 BLOODFIELD RD
R	02-8934-04-71-8470.0000	2,700.25	8	JAMES MILTON JONES ETAL	CAMDEN	267 COUNTRY CLUB RD
R	01-7988-00-91-0179.0001	1,918.10	8	THOMAS L. BROTHERS HEIRS	SOUTH MILLS	271 SLEEPY HOLLOW RD
R	02-8935-00-12-6595.0000	1,219.79	8	ANDERSON CARPENTRY SR.	CAMDEN	111 LINTON DR
R	01-7988-00-14-1370.0000	847.10	8	ISAAC CORTON	SOUTH MILLS	NORTH SIDE RD
R	02-8935-03-40-3652.1000	782.56	8	HOWARD DAVENPORT	CAMDEN	117 GIMBERRY RD
R	03-8952-00-59-0273.0000	754.31	8	DAISY WILLIAMS BURNHAM	SHILOH	RAMONS CREEK RD
R	01-7988-00-91-0179.0001	427.45	8	DAN EISEN	CAMDEN	431 158 US W
R	01-7989-04-60-1568.0000	955.01	7	EMMA BRITTE HEIRS	SOUTH MILLS	118 BLOODFIELD RD
R	03-8971-00-12-0477.0000	18,387.07	7	GILBERT WAYNE OVERTON &	SHILOH	187 THOMAS POINT RD
R	02-8945-00-54-1099.0000	7,095.06	6	GERTIE LEE & JUANOLA T BOUNTREE	CAMDEN	263 BELCHER RD
R	03-8953-04-81-9832.0000	5,259.29	5	MARLEA S. CECIL HEIRS	SHILOH	113 TROTMAN RD
R	03-8990-00-08-7291.0000	4,066.47	5	JAMES E RHODES	SHILOH	111 CATALAN DR

Top 30 Unpaid

Roll	Parcel Number	Unpaid Amount	YrAdq	Taxpayer Name	City	Property Address
P	00005640	2,525.31	1	AMERICAN TOWER CORP		
P	0001709	1,531.32	6	JOHN MATTHEW CARTE	CAMDEN	158 HWY
P	0002482	1,349.80	1	MARTEC NORTH AMERICA	CAMDEN	
P	0001046	1,110.60	10	THIEN VAN NGUYEN	SHILOH	133 EDGEWATER DR
P	0000738	1,092.13	4	LESLIE ETHERIDGE JR	CAMDEN	158 US W
P	0001538	798.61	7	JEFFREY EDWIN DAVIS	HERTFORD	MIC MAC TRAIL
P	0002342	789.69	1	ASSOCIATED TAX ADRAISERS		
P	0001972	778.93	10	DAN BUNDT	SHILOH	105 AARON DR
P	0001546	749.77	4	GEORGE HOWLAND	CAMDEN	431 158 US W
P	0001883	655.29	4	DUNG LE TRAN	SHILOH	255 SAILBOAT ROAD
P	0001739	655.07	4	COAST TO COAST POWDER COATING	CAMDEN	330 158 HWY E
P	0001829	652.02	4	KAREN BINDY	CAMDEN	431 158 US W
P	0001695	547.58	3	GARY STEWART ELKINS	CAMDEN	150 158 HWY W
P	0000659	479.52	1	RICKY'S WELDING, INC.	SHILOH	864 SANDY HOOK RD
P	0001352	443.65	9	ROBERT F. NERNEY	ELIZABETH CITY	107 SMALL DRIVE
P	0001230	411.11	3	JAMES NYE	SOUTH MILLS	101 ROBIN CT W
P	0001116	409.86	4	AL JORDAN	CAMDEN	390 158 HWY W
P	0000846	405.20	3	TOAN THINH	SHILOH	229 SAILBOAT RD
P	0001905	340.08	10	AR CORP ORATION ETAL	SOUTH MILLS	211 FLYING TIGER RD
P	0000248	326.53	10	ROBERT H. OWENS	CAMDEN	363 # 15
P	0001227	322.05	9	THIAN NGOC TRAN	SHILOH	257 SAILBOAT RD
P	0000956	314.49	10	HUNG PHI LE	SHILOH	103 EDGEWATER DR
P	0000010	278.51	8	SPIRINT NEXTEL CORPORATION	OVERLAND PARK	
P	0000295	273.70	2	HENDERSON AUDIOMETRICS, INC.	CAMDEN	330 158 HWY E
P	0000255	270.00	8	JAMES E. NASH	SOUTH MILLS	1097 343 HWY N
P	0001702	270.00	6	VAN ZANT	MCVICK	312 TULLS CREEK RD
P	0001672	268.26	6	DAVE SILVA	CAMDEN	390 158 HWY
P	0001693	261.90	6	ALLIANCE NISSAN	CAMDEN	158 HWY W
P	0002194	251.03	1	MORGAN ROBERTSON	SHILOH	849 SANDY HOOK RD S
P	0001250	247.91	5	MICHELE LEE TAYLOR	SOUTH MILLS	108 BINGHAM RD

Top 30 Oldest

Roll	Parcel Number	Unpaid Amount	YrAdq	Taxpayer Name	City	Property Address
P	0001046	1,110.60	10	THIEN VAN NGUYEN	SHILOH	133 EDGEWATER DR
P	0000738	1,092.13	10	LESLIE ETHERIDGE JR	CAMDEN	158 US W
P	0001072	778.93	10	DAN BUNDT	SHILOH	105 AARON DR
P	0000248	326.53	10	ROBERT H. OWENS	CAMDEN	363 # 15
P	0000956	314.49	10	HUNG PHI LE	SHILOH	103 EDGEWATER DR
P	0001220	219.05	10	KIMBERLY DVANE JOHNSON	SOUTH MILLS	172 KEETER BARN RD
P	0000857	139.42	10	DUG WISH LE		
P	0000316	122.12	10	JAMES P. JONES	CAMDEN	142 SANDHILLS DR
P	0000352	120.95	9	ROBERT F. NERNEY	ELIZABETH CITY	107 SMALL DRIVE
P	0001227	120.95	9	JOHN MATTHEW CARTE	SHILOH	158 HWY W
P	0001106	239.24	9	JAMI ELIZABETH VANHORN	SOUTH MILLS	617 MAIN ST
P	0000910	278.61	8	SPIRINT NEXTEL CORPORATION	OVERLAND PARK	
P	0000586	270.00	8	JAMES E. NASH	SOUTH MILLS	1097 343 HWY N
P	0001538	798.61	7	JEFFREY EDWIN DAVIS	HERTFORD	MIC MAC TRAIL
P	0001546	160.66	7	LOUIS RUGGERI	ELIZABETH CITY	CAMDEN CAISEWAY
P	0001540	120.95	7	DAVID LURE	ELIZABETH CITY	CAMDEN CAISEWAY
P	0001709	1,531.32	6	JOHN MATTHEW CARTE	CAMDEN	158 HWY
P	0001672	268.26	6	DAVE SILVA	CAMDEN	158 HWY W
P	0001693	261.90	6	ALLIANCE NISSAN	CAMDEN	158 HWY W
P	0001672	268.26	6	DAVE SILVA	CAMDEN	158 HWY W
P	0001250	247.91	5	MICHELE LEE TAYLOR	CAMDEN	108 BINGHAM RD
P	0001910	125.29	5	JEFFREY DEGAN	CAMDEN	379 COUNTRY CLUB RD
P	0001546	749.77	4	GEORGE HOWLAND	CAMDEN	431 158 US W
P	0001883	655.29	4	DUNG LE TRAN	SHILOH	255 SAILBOAT ROAD
P	0001739	655.07	4	COAST TO COAST POWDER COATING	CAMDEN	330 158 HWY E
P	0001146	409.86	4	AL JORDAN	CAMDEN	390 158 HWY W
P	0001905	340.08	4	AR CORP ORATION ETAL	SOUTH MILLS	211 FLYING TIGER RD
P	0000421	227.73	4	CLARENCE MUNDEN	CAMDEN	
P	0002081	217.24	4	ROBERT VERNON BRAY	CAMDEN	120 LAUREN LANE

243

244 The County Attorney John Morrison advised the board that Potomac Timber
245 Investments paid their taxes of \$13,979.14 in full.

246

247 Commissioner Tom White made a motion to approve the monthly tax report as
248 presented. The motion passed 5-0 with Chairman McLain, Vice Chair Sandra
249 Duckwall, Commissioners Garry Meiggs, Clayton Riggs and Tom White voting
250 aye; no Commissioner voting no; no Commissioner absent; and no Commissioner
251 not voting.

252

253

254 ***Item 7.B - Engineering Aspects of A Waste Water Treatment Plant***

255

256 Commissioner Clayton Riggs advised that the Engineer, Mr. Robey, was unable to
257 attend tonight's meeting therefore he makes a motion to recess this
258 Commissioners meeting until 3:00 Thursday in the conference room of Hyman
259 and Robey located at the intersection of Gumberry Road and US 158.

260

261 Chairman McLain adds this meeting will be open to the public.

262

263 Commissioners Riggs's motion to recess passed 5-0 with Chairman McLain, Vice
264 Chair Sandra Duckwall, Commissioners Garry Meiggs, Clayton Riggs and Tom
265 White voting aye; no Commissioner voting no; no Commissioner absent; and no
266 Commissioner not voting.

267

268

269 **Commissioner's Report**

270

271 Vice Chair Sandra Duckwall gave the Monthly Library Report.

272

273 Commissioner Tom White provided some highlights from the very successful
274 "Paddle for the Border" in which there were 311 participants and many state
275 dignitaries.

276

277 Commissioner Clayton Riggs attended a K-12 Funding Class at the School of
278 Government and wanted to let everyone know school funding reports are now on
279 line for the public to view.

280

281

282

283 Chairman Michael McLain had the following items to report:

284

285 • There is a Ribbon Cutting Ceremony for the Dollar General's Grand Opening on
286 Saturday May 9th, 2015 at 7:30 AM and invites the public to come.

287 • There is an ECBH Grant for handicap accessible playground equipment and
288 hopes the county will apply.

289

290

291 **Information from Board and Staff**

292

293 The following items were provided to the Board for their information, and a copy
294 of these items is maintained in the Clerk's office.

295

296 A. Elizabeth City Area Chamber Of Commerce

297 B. Economic Value of the College of the Albemarle

298 C. Library Report - April

299 D. Scotland County Resolution

300 E. County News April 20 2015

301 F. N.C. Rural Infrastructure Authority Approves Grants

302 G. NCACC Legislative Bulletin – April 17, 2015

303 H. NCACC Legislative Bulletin - April 24, 2015

304 I. House Bill 726

305 J. Stepping Up

306 K. Will ACOS Raise Medical Prices?

307 L. Sales Tax & Revenue Collection Report

308 M. Excise Tax Publication

309 N. Register of Deeds - April

310 O. National Flood Insurance Program Community Assistance Visit

311 P. ECBH

312 Q. LME County General Funds Report

313 R. LGFCU Gives Back

314

315

316

317

318

CAMDEN COUNTY BOARD OF COMMISSIONERS
Regular Meeting – May 4th, 2015

319 **Closed Session**

320

321 Chairman Michael McLain states the need to enter closed session pursuant to
322 NCGS 143.318.11(a)(3) and 143.318.11(a)(5) potential litigation and contract
323 negotiations.

324

325 Commissioner Garry Meiggs made a motion to enter closed session at 7:58 PM.
326 The motion passed 5-0 with Chairman McLain, Vice Chair Sandra Duckwall,
327 Commissioners Garry Meiggs, Clayton Riggs and Tom White voting aye; no
328 Commissioner voting no; no Commissioner absent; and no Commissioner not
329 voting

330

331 Commissioner Garry Meiggs made a motion to come out of closed session at 8:10
332 PM. The motion passed 5-0 with Chairman McLain, Vice Chair Sandra Duckwall,
333 Commissioners Garry Meiggs, Clayton Riggs and Tom White voting aye; no
334 Commissioner voting no; no Commissioner absent; and no Commissioner not
335 voting

336

337

338 **Meeting Recessed**

339

340 At 8:12 PM, Chairman Michael McLain asked if there were any other matters to
341 come before the Board of Commissioners, hearing none, and by acclamation the
342 meeting was recessed until 3:00 PM Thursday in the conference room of Hyman
343 and Robey located at the intersection of Gumberry Road and US 158.

344

345

346

347

348

Chairman Michael McLain
Camden County Board of Commissioners

349

350

351 ATTEST:

352

353

354

355 Angela L. Wooten

356 Clerk to the Board

1 Camden County Board of Commissioners
2 Regular Meeting
3 June 1st, 2015
4 6:00 PM Closed Session
5 7:00 PM - Regular Meeting
6 Historic Courtroom, Courthouse Complex
7 Camden, North Carolina
8 MINUTES
9

10 *The regular meeting of the Camden County Board of Commissioners was held on June*
11 *1st, 2015 in the Historic Courtroom, Camden, North Carolina. The following*
12 *Commissioners were present:*
13

14 *Chairman Michael McLain, Vice Chair Sandra Duckwall,*
15 *Commissioners Garry Meiggs, Clayton Riggs and Tom White;*
16

17 *Also attending were the County Manager Michael Renshaw, County Attorney John*
18 *Morrison and Clerk to the Board Angela Wooten. Present for purposes of making a*
19 *presentation(s) or providing supporting information for agenda items were the following*
20 *persons: Public Works Director, David Credle and the Finance Officer Stephanie*
21 *Humphries.*
22

23
24 **Closed Session**
25

26 *Chairman Michael McLain states the need to enter closed session pursuant to NCGS*
27 *143.318.11(a)(3) and 143.318.11(a)(4) to consultation with Attorney to discuss Current*
28 *Litigation Case Number: 2:15-cv-00021 - Camden County et al v. Northeastern*
29 *Community Development Corporation et al & to discuss economic development*
30 *incentives.*
31

32 *Commissioner Clayton Riggs made a motion to enter closed session at 6:03 PM. The*
33 *motion passed 5-0 with Chairman McLain, Vice Chair Sandra Duckwall, Commissioners*
34 *Garry Meiggs, Clayton Riggs and Tom White voting aye; no Commissioner voting no; no*
35 *Commissioner absent; and no Commissioner not voting*
36

37 *Commissioner Garry Meiggs made a motion to come out of closed session at 6:42 PM.*
38 *The motion passed 5-0 with Chairman McLain, Vice Chair Sandra Duckwall,*
39 *Commissioners Garry Meiggs, Clayton Riggs and Tom White voting aye; no*
40 *Commissioner voting no; no Commissioner absent; and no Commissioner not voting*
41

42 **Regular Session, 7:00 P.M.**
43

CAMDEN COUNTY BOARD OF COMMISSIONERS

Regular Meeting – June 1st, 2015

44 *Joining the board in regular session for purposes of making a presentation(s) or*
45 *providing supporting information for agenda items were the following persons: Public*
46 *Works Director, David Credle, Finance Officer Stephanie Humphries., Planning Director*
47 *Dan Porter, Tax Administrator Lisa Anderson and Librarian Krystal Lancaster*

48

49 **Call to Order**

50

51 *Chairman Michael McLain called to order the June 1st, 2015 meeting of the Camden*
52 *County Board of Commissioners at 7:00 PM.*

53

54

55 **Invocation and Pledge of Allegiance**

56

57 *Chairman Michael McLain gave the invocation and led those present in the Pledge of*
58 *Allegiance.*

59

60

61 **Public Comments** - None

62

63

64 **Consideration of Agenda**

65

66 *Chairman Michael McLain asked if there were any changes to the agenda.*

67

68 *The County Manager Mike Renshaw requested to have three items added to agenda.*

69

- 70
- *Item 3.C - NCDOT Road Program Update*
 - *Item 5.F – Support of Currituck Opposition to House Bill 97*
 - *Item 5.G - Camden Bears Football Discussion*

71

72

73 *Vice Chairwoman Sandra Duckwall made a motion to approve the agenda as amended.*
74 *The motion passed 5-0 with Chairman McLain, Vice Chair Sandra Duckwall,*
75 *Commissioners Garry Meiggs, Clayton Riggs and Tom White voting aye; no*
76 *Commissioner voting no; no Commissioner absent; and no Commissioner not voting.*

77

78

79 **Presentations**

80

81 **Item 3.A - Elizabeth P. Floyd, CPA, PHR - Chief Financial Officer, NCACC**

82

83 *The Chief Financial Officer of the NCACC, Mrs. Floyd, came before the board of*
84 *commissioners to thank them for their continued membership. She informs everyone*

85 *that Camden should all be proud to have two board members that have served on the*
86 *NCACC board of directors. Then Ms. Floyd gave a brief overview of the benefits NCACC*
87 *members receive.*

88

89 *Benefits*

- 90 • *Education*
 - 91 ○ *Advanced leadership training*
- 92 • *Conferences*
- 93 • *Risk Management Insurance Pools*
 - 94 ○ *Liability and Property*
 - 95 ○ *Workers compensation*
- 96 • *Debt Set off Program*
 - 97 ○ *Camden has recouped almost \$87,000 from uncollected debts.*
- 98 • *Lobbying*
- 99 • *Advocacy*
- 100 • *Expanded Services in Research*

101 *She also stated that the NCACC has recently expanded services in their research*
102 *department and members have received a return of Fund Balance for the first time in*
103 *her 20 years with the NCACC.*

104

105 *Item 3.B - Lisa Phillips – ARHS*

106

107 *Mrs. Phillips gave a presentation about the negative effects of smoking.*

108

109 *Item 3.C – William Bridgers – NCDOT Road Program Update*

110

111 *Assistant Division Maintenance Engineer William Bridgers came before the board to*
112 *share some details about the Budget and Program status.*

113

CAMDEN COUNTY BOARD OF COMMISSIONERS
 Regular Meeting – June 1st, 2015

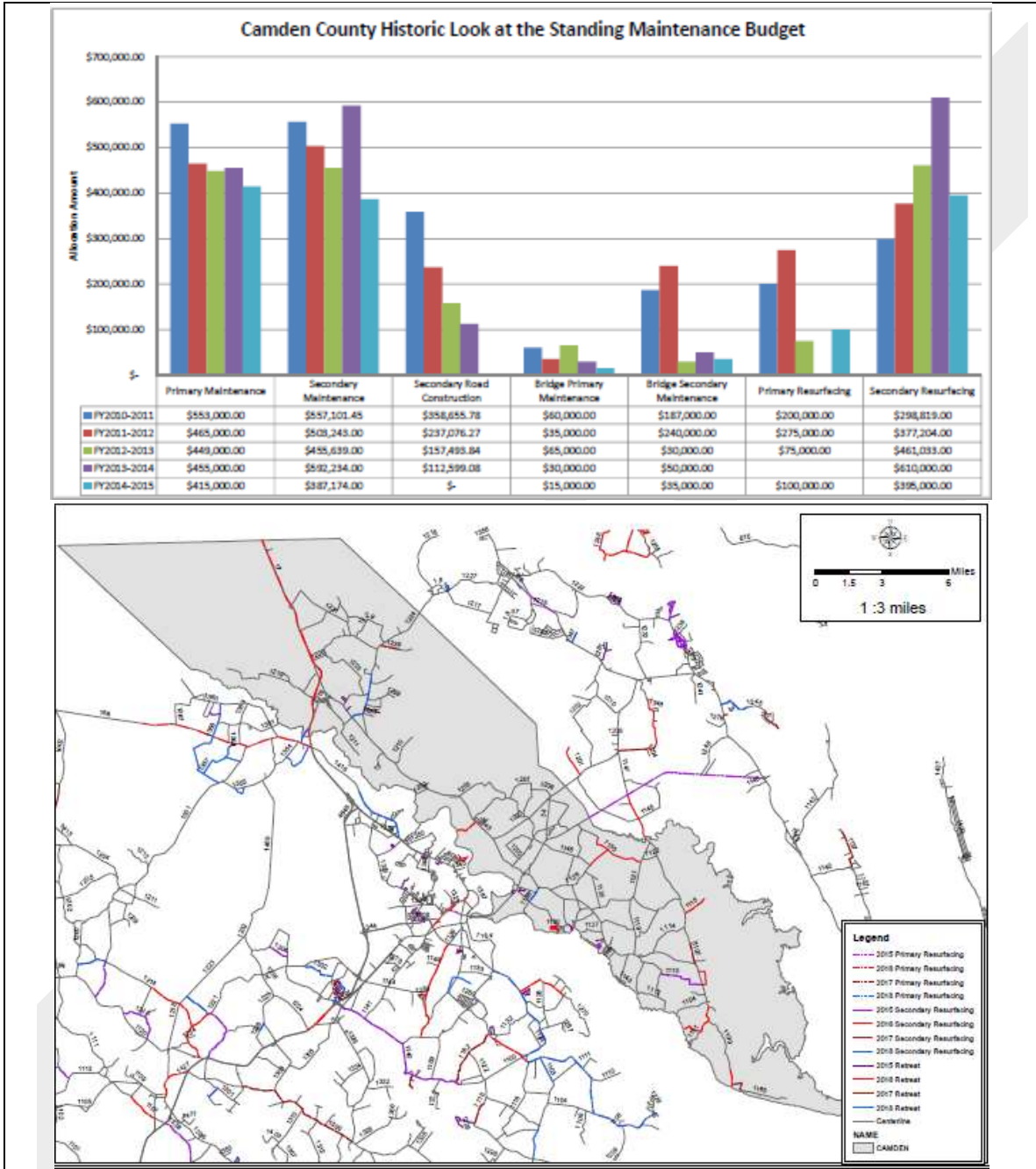

114

115

116 **Old Business**

117

118 **Item 4.A - Ordinance 2015-04-01 – Rezoning Application – (UDO 2015-03-11) Harbinger**
 119 **Land & Timber LLC and Assorted Development Corp. Gary Dunston.**

120

121 *Planning Director Dan Porter reminded the board that at a Public Hearing held on May*
 122 *5th, 2015 staff presented the facts and findings of this Zoning issue.*

123
124
125
126
127
128
129
130
131
132
133
134
135
136
137
138
139
140
141
142
143
144
145
146
147
148
149
150
151
152
153
154
155
156
157
158
159
160
161
162
163
164
165

Mr. Gary Dunstan owner/part owner of both properties has applied to rezone approximately 41 (farmland) of the 50 plus acres from Basic Residential (R3-2) to Basic Residential (R3-1). Property located at the intersections of Sandy Lane, Keeter Barn and Sharon Church Roads in South Mills Township. Staff presented the rezoning to the Planning Board on April 15, 2015 with the applicant present and after discussion Planning Board made the following motions:

- 1. Consistency Statement: Approved a motion that the application for rezoning was consistent with both the CAMA Land Use Plan and Comprehensive Plan as both allowed densities of 1 acre lots.*
- 2. Motion was made and approved to rezone the 41 acres (farmland) from Basic Residential (R3-2) to Basic Residential (R3-1).*

Mr. Porter then answered a few questions from the board.

Commissioner Garry Meiggs made a motion to approve the rezoning as it is consistent with both the CAMA Land Use Plan and the Comprehensive Plan fin that they both allow densities of one acre or more for that area and are a minimal impact on traffic and surrounding areas. The motion passed 5-0 with Chairman McLain, Vice Chair Sandra Duckwall, Commissioners Garry Meiggs, Clayton Riggs and Tom White voting aye; no Commissioner voting no; no Commissioner absent; and no Commissioner not voting.

Commissioner Tom White made a motion to rezone the 41 acres (farmland) from Basic Residential (R3-2) to Basic Residential (R3-1). Ordinance No. 2015-04-01 as presented.. The motion passed 5-0 with Chairman McLain, Vice Chair Sandra Duckwall, Commissioners Garry Meiggs, Clayton Riggs and Tom White voting aye; no Commissioner voting no; no Commissioner absent; and no Commissioner not voting.

Public Hearings – None

New Business

Item 5.A - New Library Hours of Operation

The County Librarian Krystal Lancaster presented a revised holiday schedule and daily operating hours as requested by the Camden Library Board of Trustees. The increase in hours should not cause any increases in salary; however, the Finance Officer has estimated that utility costs may increase by \$1,600 based on previous usage.

166
167

Proposed Camden Public Library Holiday Closure Schedule

<u>In Observation of:</u>	<u>Library Will Be Closed On:</u>
New Year's Day	January 1st
Martin Luther King, Jr. Day	3 rd Monday in January
Good Friday	Friday
Easter Sunday	Sunday
Memorial Day	Last Monday in May
July 4 th	July 4th
Labor Day	1 st Monday in September
Veterans Day	November 11th
Thanksgiving Day	3 rd week/Thursday and Friday in Nov
Christmas	December 24 th , 25 th , and 26 th

168
169

Proposed Camden Public Library Operating Hours

170
171

April 1 – October 31, Monday – Saturday, staff will arrive at 8:00 a.m., doors will open at 9:00 a.m. and will close at 8:00 p.m.

172

November 1 – March 31, Monday – Saturday, staff will arrive at 8:00 a.m., doors will open at 9:00 a.m. and will close at 6:00 p.m.

173

During the entire year, on Sunday, the staff will arrive at 12:30 p.m., doors will open at 1:00 p.m. and will close at 5:00 p.m.

174

It was agreed there would be no trial period for the new operating hours and the Monday-Saturday hours will be effective July 1, 2015. Sunday hours will be effective November 1, 2015.

175

Commissioner Tom White made a motion to approve the proposed Library hours as presented. The motion passed 5-0 with Chairman McLain, Vice Chair Sandra Duckwall, Commissioners Garry Meiggs, Clayton Riggs and Tom White voting aye; no Commissioner voting no; no Commissioner absent; and no Commissioner not voting.

176

177

178

Item 5.B - Resolution Supporting Alternative Governance Structure for the Area Authority (Area Board of ECBH and Coastal Care) Serving Camden County

179

The County Manager reminds the board of Liza Wainwrights April 20th presentation requesting the board's approval of ECBH and Coastal Care merger.

180

The County Manager's Office has been advised that eighteen of the nineteen counties previously served by ECBH have approved the attached Alternative Governance

181

CAMDEN COUNTY BOARD OF COMMISSIONERS
Regular Meeting – June 1st, 2015

200 *structure. The Camden County Board of Commissioners is now being asked to formally*
201 *adopt the attached resolution in support of this Alternative Governance Structure. By*
202 *approving the attached resolution, the Camden County Board of Commissioners will*
203 *have the ability to appoint one elected official and one non-elected representative to*
204 *serve on the Area Authority Regional Board.*

205
206 *The County Manager has been advised that this decision is needed in order for the*
207 *Regional Board to schedule and hold its first meeting prior to July 1, 2015. Should the*
208 *Board of Commissioners opt not to approve and adopt the attached resolution Camden*
209 *County may not have an opportunity to have representatives on the Area Authority*
210 *Regional Board.*
211

Resolution No. 2015-06-01

Resolution of Support for an Alternative Governance Structure for the Area Authority serving
Camden County

WHEREAS, in accordance with N. C. General Statute § 122C - 115 (c1), the Area Board of CoastalCare, an Area Authority serving Brunswick, Carteret, New Hanover, Onslow and Pender Counties and the Area Board of East Carolina Behavioral Health, an Area Authority serving Beaufort, Bertie, Camden, Chowan, Craven, Currituck, Dare, Gates, Hertford, Hyde, Jones, Martin, Northampton, Pamlico, Pasquotank, Perquimans, Pitt, Tyrrell, and Washington Counties, have entered into an agreement to consolidate their agencies into a twenty-four county Area Authority serving all previously names counties; and

WHEREAS, the Secretary of the N. C. Department of Health and Human Services has approved this consolidation, as required by law; and

WHEREAS, N. C. General Statute § 122C - 118.1, which specifies the composition of an Area Authority Board, permits an alternative Area Board structure to be implemented 1) if the total population of the Area Authority catchment area exceeds 1,250,000 and 2) if the counties which comprise the Area Authority agree by resolution to an alternative structure; and

WHEREAS, the total population of the new Area Authority created by the consolidation of CoastalCare and East Carolina Behavioral Health is 1,260,778; and

WHEREAS, it is in the best interest of the residents of the twenty-four counties to approve an alternative governance structure for the consolidated Area Authority;

NOW, THEREFORE, BE IT RESOLVED, that we, the Camden County Board of Commissioners, do hereby approve the structure of the Area Board and the Regional Advisory Boards of the consolidated Area Authority, as outlined below.

To provide a local presence in the counties served and to assure that each county has input into the services received by its residents, the twenty-four county catchment area will have three regions. The regions have been designed to equalize, to the extent possible, the number of

COPY

CAMDEN COUNTY BOARD OF COMMISSIONERS
Regular Meeting – June 1st, 2015

counties, population in the region, and overall square mileage of the regions. The three regions and the counties served are:

Northern Region: Bertie, Camden, Chowan, Currituck, Gates, Hertford, Martin, Northampton, Pasquotank and Perquimans Counties.

Central Region: Beaufort, Craven, Dare, Hyde, Pamlico, Pitt, Tyrell and Washington Counties.

Southern Region: Brunswick, Carteret, Jones, New Hanover, Onslow and Pender Counties.

The counties in each region will appoint two members to the Regional Advisory Board: one county commissioner or designee and another individual who meets the requirements outlined in N. C. G. S. § 122C-118.1 (b). In addition, the Regional Advisory Board will include the Chair or designee of the regional Consumer and Family Advisory Committee. County Commissioner members of the Regional Advisory Boards may serve for as long as they are a commissioner. Other members of the Regional Advisory Board may serve for up to three, three year consecutive terms.

The primary functions of the Regional Advisory Board will be to advise the Area Authority Chief Executive Officer on the evaluation and hiring of a Regional Director; recommending priorities for expenditure of state and county funds for development of the annual budget; determining local priorities for inclusion in the overall strategic plan; identifying community needs and concerns; monitoring resolution of issues; and monitoring performance at the local level, including access to care, expenditure of service funds, number of consumers served, services delivered, provider network size and composition, outcomes, and consumer satisfaction.

Each Regional Advisory Board will establish its own bylaws based on local needs, but in compliance with standardized requirements established by the Governing Board for quorums, frequency of meetings, elections of officers, duties of members, committees and committee appointments, and attendance standards. Such bylaws are subject to the approval of the Governing Board.

Each Regional Advisory Board will select four (4) members to serve as the Area Authority Governing Board: one county commissioner, the Consumer and Family Advisory Committee chair or designee, and two other members. In addition, the chair or designee of the Area Authority Network Council shall serve on the Governing Board as a non-voting member. The county commissioner members of the Governing Board shall serve one three year term without consecutive reappointment, so that commissioner representation on the Governing Board will rotate among the counties in each region. The other members of the Governing Board may serve three, three year terms.

The Governing Board's primary responsibilities will include determining policy; strategic planning, including consideration of local priorities as determined by the Regional Advisory Boards; budgets; hiring and evaluations of the Chief Executive Officer; monitoring deliverables, including overall performance and financial management; government affairs and

advocacy; reporting to constituent counties; responding to concerns and feedback from the Regional Advisory Boards; reviewing, revising and approving the Regional Advisory Board bylaws; and all other responsibilities outlined in N. C. law for Area Authority Boards. The Governing Board will develop and adopt bylaws to address its activities in accordance with law.

ADOPTED this 1st day of June, 2015.

ATTEST:



Clerk to the Board



Chairman of County Commissioners

212
213
214
215
216
217
218
219

Commissioner Garry Meiggs made a motion to adopt the resolution as presented. The motion passed 4-1 with Vice Chair Sandra Duckwall, Commissioners Garry Meiggs, Clayton Riggs and Tom White voting aye; Chairman McLain voting no; no Commissioner absent; and no Commissioner not voting.

220 Item 5.C - Student Generation Rates

221

222 *Planning Director Dan Porter advised the board that on April 16 the APFO Coordinating*
223 *Committee recommended changing the Student Generation Rate for tracking impacts of*
224 *housing development. If approved the new rates will be applied retroactively to the*
225 *beginning of the current school year and carried forward into future years. The table*
226 *below shows the exiting rates versus the rates as calculated from actual development*
227 *over the last 10 years.*

228

Student Generation Rates				
<i>Old Projection</i>			<i>Actual 2003-2014</i>	
<i>641 Houses CO'd</i>				
	<i>Rate</i>	<i>Students</i>	<i>Students</i>	<i>Rate</i>
<i>Elementary</i>	<i>0.2</i>	<i>128.2</i>	<i>155</i>	<i>0.2418</i>
<i>Middle</i>	<i>0.12</i>	<i>76.92</i>	<i>149</i>	<i>0.2324</i>
<i>High</i>	<i>0.12</i>	<i>76.92</i>	<i>114</i>	<i>0.1778</i>
Total	0.44	282.04	418	0.6521

229

230

231 *Commissioner Clayton Riggs made a motion to approve the new Student Generation*
232 *Rates as elementary .24, middle .23, and high school .18 for a total of .65 students per*
233 *school.*

234

235 *Commissioner Garry Meiggs wants to know what history is involved in the elementary*
236 *school numbers because the enrollment numbers have dropped. Dan Porter advised*
237 *these numbers are based on a 10 year calculation.*

238

239 *After some discussion Commissioner Riggs withdraws his motion and requests*
240 *information based on 3 year, 5 year, and 10 year development numbers.*

241

242

243 Item 5.D - Resolution Supporting EDA Public Works Grant Application

244

245 *The County Manager Mike Renshaw states that Camden County staff has prepared an*
246 *application to the Economic Development Administration to assist in constructing an*
247 *80,000 GPD sewer treatment plant in the Courthouse Township at a projected cost of*
248 *approximately \$1.8 million. The maximum EDA grant available is \$500,000 and requires*
249 *a \$500,000 local matching contribution.*

250

CAMDEN COUNTY BOARD OF COMMISSIONERS
Regular Meeting – June 1st, 2015

Resolution No. 2015-06-02

A Resolution of the Camden County Board of Commissioners Supporting the application for Public Works Assistance from the Economic Development Administration

WHEREAS, Camden County is in need of additional sewer capacity to serve increasing business activity along US Hwy 158 in the Courthouse Township area; AND

WHEREAS, the Economic Development Administration (EDA) has a competitive public works infrastructure grant program to construct infrastructure facilities which promote economic development of distressed regions; AND

WHEREAS, Camden County Census Tract 37029950102 meets the EDA unemployment distress criteria for program eligibility; AND

WHEREAS, the location primary beneficiaries is the above referenced census tract, AND

WHEREAS, The County has owns a 60 acre tract of land adjacent to the census tract to site a sewer treatment plant and high rate infiltration ponds; AND

WHEREAS, the county has prepared a Preliminary Engineering Report and conducted soil suitability tests, AND

WHEREAS, the projected cost of the proposed 80,000 gallon per day Amphidrome treatment plant and related high rate infiltration ponds is approximately \$ 1.8 million

NOW, THEREFORE, BE IT RESOLVED, That Camden County Board of Commissioners approves submittal of an application for Public Works assistance from the Economic Development Administration for \$300,000 to assist construction of an Amphidrome Wastewater Treatment Plant, and it is resolved that the Board will provide the required \$300,000 matching cash contribution.

ADOPTED this 1st day of June, 2015.

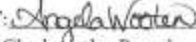
ATTEST: 
Clerk to the Board

Chairman of County Commissioners



251

252 *Vice Chairwoman Sandra Duckwall made a motion to approve the Resolution as with the*
253 *modification. The motion passed 5-0 with Chairman McLain, Vice Chair Sandra*
254 *Duckwall, Commissioners Garry Meiggs, Clayton Riggs and Tom White voting aye; no*
255 *Commissioner voting no; no Commissioner absent; and no Commissioner not voting.*

256

257

258 Item 5.E - FY 2015-2016 Annual Budget Message Presentation

259

260 *The County Manager Mike Renshaw presents an overview of the proposed FY 2015-2016*
261 *Annual Budget. He advises the public that two budget work sessions were held with the*
262 *Board of Commissioners on May 19th and 21st, and there will be a Public Hearing on the*
263 *Proposed Budget on June 8th at 7:00 P.M. in the Historic Courthouse. A detailed budget*
264 *document is available at the Camden County Administrative Office (330 US HWY 158*
265 *East) for public review.*

266

267

268

CAMDEN COUNTY BOARD OF COMMISSIONERS
Regular Meeting – June 1st, 2015

269 Budget Priorities

- 270 • *Implement an Ad Valorem tax at .68/\$100 based upon recent revaluation*
- 271 *(calculated revenue-neutral rate is .69/\$100 valuation)*
- 272 • *Provide a 2% Cost of Living Allowance to county staff*
- 273 • *Invest wisely in critical water and wastewater treatment infrastructure*
- 274 • *Fund expanded EMS in the county through addition of a second ambulance crew*
- 275 *in South Mills Station 14*
- 276 • *Reduce departmental operating expenses wherever possible*
- 277 • *Maintain a healthy reserve fund balance in accordance with financial policies*
- 278 *outlined in Resolution 2007-05-04*
- 279 • *Continue to provide outstanding government services at adequate levels*

280 Economic Forecast

- 281 • *NC economy still slow to recover, expanding at only 1.7% in 2014*
- 282 • *NCACC projects continued slow growth statewide of 3-4% in FY 15-16*
- 283 • *Growth rate highly dependent upon local economic climate, housing starts, and*
- 284 *state tax reform efforts*
- 285 • *Aging population foretells lower consumer spending and smaller labor force*
- 286
- 287 • *Fourteen of the 15 state economic sectors are expected to grow modestly, led by*
- 288 *construction at 5.5%*
- 289 • *Uptick in Camden retail/commercial economic activity*

290 Budget Snapshot

- 291 • *General Fund Budget of \$11,802,839 (a 2.7% increase from FY 2014-2015)*
- 292 • *Proposed Ad Valorem tax rate of .68 cents/\$100 valuation (revenue-neutral tax*
- 293 *rate calculated to be .69 cents/\$100)*
- 294 • *Proposed 3% Increase for School Current Expense, 100% of Capital Outlay*
- 295 *Requested*
- 296 • *2% Cost of Living Adjustment for County Staff*
- 297 • *Two new positions for FY 2015-2016 • Water/Sewer Distribution/Collection*
- 298 *Operator (Full Time) • Solid Waste/Recycling Maintenance Worker (Part Time)*
- 299 • *Funding of a second EMS crew in South Mills Township*
- 300 • *Appropriation of \$89,000 for Unified Development Ordinance re-write*

301
302
303
304
305

306
 307
 308
 309

Major General Fund Expenditures

Department	FY 2014-2015	FY 2015-2016
Governing Body	\$103,515	\$95,614
Administration	\$227,360	\$214,667
Elections	\$104,080	\$133,494
Finance/HR	\$278,002	\$273,745
Tax Office	\$410,780	\$404,850
Legal	\$50,000	\$50,000
Register of Deeds	\$224,120	\$202,714
Planning/Inspections	\$411,698	\$480,978
Public Works/Building & Grounds	\$477,203	\$532,956
Sheriff/SRO	\$1,611,646	\$1,680,588
Extension	\$77,762	\$101,540
Parks & Recreation	\$262,054	\$261,180
Senior Center	\$121,589	\$121,017
Solid Waste	\$654,950	\$646,413
Non-Departmental	\$242,808	\$198,643
Economic Development	\$150,918	\$159,953
Capital Outlay/Debt Service	\$1,153,935	\$1,050,321
Library	\$198,180	\$198,861
JCPC	\$67,077	\$67,631
Soil & Water Conservation	\$67,312	\$62,263

310
 311
 312
 313
 314

Departmental Expense as Percentage of GF

Department	%
Governing Body	0.8%
County Administration	0.2%
Elections	1.1%
Finance Department	1.7%
Personnel	0.6%
Tax Department	3.4%
Legal (including OLF)	0.4%
Register of Deeds	1.7%
Planning Dept./Inspections	4.0%

CAMDEN COUNTY BOARD OF COMMISSIONERS
 Regular Meeting – June 1st, 2015

Public Works/Bldg. & Grounds	4.5%
Non-Departmental	1.7%
Sheriff & SRO	14.2%
Solid Waste	5.4%
Coop. Extension	0.8%
Recreation	2.2%
Senior Center	0.1%
Economic Development	1.3%
Capital Outlay/Debt Service	8.8%
Special Appropriations	39.4%

315
 316
 317
 318

Special Appropriations Breakout

School Current Expense	44.6%
Pasquotank Camden EMS	10.4%
Central Communications/EM	5.7%
College of the Albemarle	1.0%
Albemarle District Jail	8.7%
Dept. of Social Services	7.0%
Courthouse Shiloh VFD	5.2%
South Mills VFD	3.1%
School Capital Reserve Fund	7.0%

319
 320
 321
 322

General Fund Revenue Summary

Source	FY 2014-2015	FY 2015-2016
Ad Valorem Tax	\$6,309,347	\$6,274,220
Local Option Sales Tax (Article 39)	\$525,000	\$565,000
Vehicle Tax	\$573,200	\$517,450
Franchise Tax	\$400,000	\$625,000
Medicaid Hold Harmless	\$650,000	\$650,000
Article 40 Tax	\$360,000	\$425,000
Article 42 Tax	\$125,000	\$125,000
Special Revenue Fund (CRF for Debt Payments)	\$458,702	\$376,283
School Reserve Fund	\$695,232	\$1,005,321

323
 324
 325

New Staff Position Summary

Department	Position Title	Salary & Benefits
Water/Sewer	Distribution/Collection Operator	\$45,657
Solid Waste/Recycling	Maintenance Worker (Part Time)	\$5,851

Summary

- *Proposed budget will meet the Board of Commissioners goals and priorities in a fiscally responsible manner*
- *Addresses modest capital and staffing needs in several departments*
- *Meets obligated payments of annual debt service*
- *Provides adequate funding for the Camden County Public School's operational and capital outlay needs*
- *Addresses critical capital infrastructure needs*
- *Proposed appropriation of only \$95,178 of general fund balance*

Item 5.F – Support of Currituck Opposition to House Bill 97

The Currituck Chairman Paul O'Neal sent a letter requesting the Camden County Board of Commissioners support Currituck's opposition to house bill 97.

Commissioner Clayton Riggs made a motion to have staff draft a letter not supporting the removal of the Bonus Allocation of \$100,000. The motion passed 5-0 with Chairman McLain, Vice Chair Sandra Duckwall, Commissioners Garry Meiggs, Clayton Riggs and Tom White voting aye; no Commissioner voting no; no Commissioner absent; and no Commissioner not voting.

Item 5.G - Camden Bears Football Discussion

In a letter dated May 27th the Camden Youth Football & Cheerleading program administrators indicated they would like to turn over operations to Camden County Parks and Recreation department as they are no longer able to provide these services.

Chairman McLain and Commissioner Riggs confirm that the Shiloh Sharks have the appropriate liability insurance.

CAMDEN COUNTY BOARD OF COMMISSIONERS
Regular Meeting – June 1st, 2015

364 **Board Appointments**

365

366 **Item 6.A - Economic Improvement Council**

367

368 *This appointment was deferred from the May 4th, 2015 BOC meeting as the*
369 *county does not have a volunteer to serve on the Economic Improvement*
370 *Council. If anyone is interested the clerk has posted a vacancy announcement on*
371 *the county website.*

372

373

374 **ITEM 6.B - Economic Development Commission**

375

Dear Mr. Purcell:

At the June 1st, 2015 Camden County Board of Commissioners meeting, the Board voted to appoint you to serve the Camden Economic Development Commission for a 2 year term, expiring May 30th, 2017.

If you have any questions, please feel free to call at 252-338-6363 ext. 100.

Thank you for your willingness to serve the citizens of Camden County.

Sincerely,



Angela L. Wooten, Clerk to the Board
Camden County Board of Commissioners

cc: Board of Commissioners
Will Meiggs, Chairman
File

376

377 *Commissioner Garry Meiggs made a motion to appoint Christopher Purcell to serve the*
378 *Camden Economic Development Commission for a 2 year term expiring May 30th, 2017.*
379 *The motion passed 5-0 with Chairman McLain, Vice Chair Sandra Duckwall,*
380 *Commissioners Garry Meiggs, Clayton Riggs and Tom White voting aye; no*
381 *Commissioner voting no; no Commissioner absent; and no Commissioner not voting*

382

383

384 **ITEM 6.C - Library Board of Trustees**

385

386

CAMDEN COUNTY BOARD OF COMMISSIONERS
Regular Meeting – June 1st, 2015

June 5th, 2015

Mary Leigh Barrett
202 Valley Rd.
Camden, NC. 27921

RE: Appointment to Library Board of Trustees

Dear Ms. Barrett:

At the June 1st, 2015 Camden County Board of Commissioners meeting, the Board voted to appoint you to the Library Board of Trustees with a 3 year term expiring 5/30/2018.

If you have any questions, please call Nell Morrison at (252) 331-5338.

Thank you for your willingness to serve the citizens of Camden County.

Sincerely,

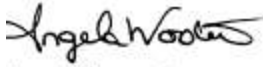

Angela Wooten, Clerk to the Board
Camden County Board of Commissioners

387
388
389
390
391
392
393
394

Commissioner Tom White made a motion to appoint Mary Leigh Barrett to serve the Library Board of Trustees for a 3 year term expiring May 30th, 2018. The motion passed 5-0 with Chairman McLain, Vice Chair Sandra Duckwall, Commissioners Garry Meiggs, Clayton Riggs and Tom White voting aye; no Commissioner voting no; no Commissioner absent; and no Commissioner not voting.

395
396
397

Consent Agenda

398
399
400
401

Commissioner Garry Meiggs made a motion to approve the consent agenda as presented. The motion passed 5-0 with Chairman McLain, Vice Chair Sandra Duckwall, Commissioners Garry Meiggs, Clayton Riggs and Tom White voting aye; no Commissioner voting no; no Commissioner absent; and no Commissioner not voting.

402
403
404

Item 7.A - Draft Minutes – March 9th, 2015 BOC Retreat

405
406
407
408

Item 7.B - Budget Amendments – BA023

CAMDEN COUNTY BOARD OF COMMISSIONERS
 Regular Meeting – June 1st, 2015

Section I. To amend the Dismal Swamp Visitor Center as follows:

ACCT NUMBER	DESCRIPTION OF ACCT	AMOUNT	
		INCREASE	DECREASE
606000-503000	PT Salaries	\$1,500.00	
606000-514000	Travel		\$500.00
606000-510000	Training		\$300.00
606000-532000	Office Supplies		\$500.00
606000-511000	Telephone & Postage		\$200.00

This Budget Amendment is made to increase Part Time Salaries to cover leave for Full Time employee.

This will result in a decrease of \$0 in the Contingency of the General Fund.

Balance in Contingency \$23,500.00

409
 410
 411
 412

Item 7.C - School Budget Amendments

Code Number	Description of Code	Amount	
		Increase	Decrease
5100	Regular Instructional Programs	5,802.76	
5200	Special Instructional Programs	5,200.00	
5800	School Based Support Services		5,200.00
6100	Support & Development Serv.		500.00
6500	Operational Support Services	4,845.00	
Explanation: Appropriate NC Arts Council carryover funds and additional revenue for Activity Bus Operations			
Total Appropriation in Current Budget		\$	1,469,921.83
Amount of Increase/Decrease of Above Amendment			10,147.76
Total Appropriation in Current Amended Budget		\$	1,480,069.59

Code Number	Description of Code	Amount	
		Increase	Decrease
9100	Category I Projects	.00	
9300	Category III Projects		1,775.20
Explanation:			
Total Appropriation in Current Budget		\$	658,748.60
Amount of Increase / (Decrease) of Above Amendment			- 1,775.20
Total Appropriation in Current Amended Budget		\$	656,973.40

CAMDEN COUNTY BOARD OF COMMISSIONERS
Regular Meeting – June 1st, 2015

421 Item 6.F - Tax Authorization to Collect (July Renewals)
422

SOUTH MILLS	COURTHOUSE	SHILOH	TOTAL
19,333.86	19,140.19	12,680.47	51,154.52

423
424 Item 7.G - Volunteer Form
425

Application for Citizen Service - Volunteer Form

If you are a citizen of Camden County and would like to serve on one of the County's boards or commissions, please complete this application and return it to the County Manager's Office, 300 East HWY 158, mail to P.O. Box 158, Camden, North Carolina 27921 or e-mail monahaw@camdencountync.gov.

Name Gail Dickinson

Mailing Address 120 Dogwood Drive, Camden, NC 27921

Township you live in: Courthouse (Whitehall Shores)

Telephone (home) 252-619-8435 cell (business)

Email address gdickins@odu.edu

Are you a registered voter? Yes No

Have you ever been convicted of a felony? Yes No

Please identify any talent, interest, skill, experience or educational preparation which might be helpful to a board or commission: MLS degree - UNC-Chapel Hill (1987), PhD - University of Virginia, Associate Dean for Graduate Studies, Darden College of Education, ODU, Professor of Library Science -- ODU, Past President - American Association of School Librarians, Member, Friends of the Library, Member, United for Libraries (ALA division for library friends, trustees, and boards).

Board or Commissions upon which you are interested in serving: (List on opposite side)
Library Board

As a member of a Board or Commission, you will be expected to attend at least 75% of the meetings. Please note the by-laws of some Boards and Commissions limit the number of terms served. This application is a notification of your interest to serve on a Board or Commission to be considered by the Board of Commissioners when a vacancy occurs. Thanks for your interest in Camden County Government.

Signature Gail Dickinson Date 5/4/2015

Created 8/11/2009

426
427
428
429 Item 7.H - Set Public Hearing Date

430
431 Set the Capital Improvement Plan Public Hearing Date for June 15th, 2015 @ 7:00 PM.
432

433
434 Commissioner's Report

435
436 Vice Chair Sandra Duckwall
437

- May's Library Report.

438 Commissioner Garry Meiggs
439

- RFPs Albemarle Regional Health Services' RFPs are due today June 1st and he should have more information next week.

441
442

443

444 *Chairman McLain*

- 445 • *Audit appears to be approved*
- 446 • *Solar Farms presentation at Albemarle Commission*
- 447 • *Not reliable source of power*
- 448 • *Only produces 5 hours per day*
- 449 • *Massively Increases power bill*
- 450 • *Government funded*

451

452 **County Manager's Report**

453

- 454 • *One Mill Park is almost complete.*
- 455 • *The County Museum Track lighting is finished and the Museum should open in*
- 456 *September.*
- 457 • *Mr. Armstrong, Director of Recreation Resource Services has at NC State has*
- 458 *found some funding for the Dismal Swamp Trail Extension.*
- 459 •

460 **Information from Board and Staff**

461

462 *The following items were provided to the Board for their information, and a copy of*

463 *these items is maintained in the Clerk's office.*

464

- 465 A. *Library Monthly Report – May 2015*
- 466 B. *Sheriff's Monthly Report - Apr 2015*
- 467 C. *EMS Reports*
- 468 D. *Professional Development Program*
- 469 E. *Resolution by Moore Co*
- 470 F. *NCACC Budget Summary*
- 471 G. *Jobs Incentive Program for Tier 1 Counties*
- 472 H. *NCACC Legislative Bulletin – May 8th, 2015*
- 473 I. *NCACC Legislative Bulletin – May 15th, 2015*
- 474 J. *Resolution to Establish a National Task Force to address*
- 475 *Coastal Issues*
- 476 K. *Resolution requesting revenue sharing*
- 477 L. *Sales Tax Report*
- 478 M. *BizConnect Broadband Pilot Grant Award*
- 479 N. *Businesses Receive \$246,000 to Invest in Workers' Skills*

480

481

482

483

CAMDEN COUNTY BOARD OF COMMISSIONERS
Regular Meeting – June 1st, 2015

484

485 ***Meeting Adjourned***

486

487 *At 8:55 PM, Chairman Michael McLain asked if there were any other matters to come*
488 *before the Board of Commissioners, hearing none, and by acclamation the meeting was*
489 *adjourned.*

490

491

492

Chairman Michael McLain
Camden County Board of Commissioners

493

494

495 ATTEST:

496

497

498

499 Angela L. Wooten

500 Clerk to the Board

1 **Camden County Board of Commissioners**
2 **Regular Meeting**
3 **June 15th, 2015**
4 **7:00 P.M. - Regular Meeting**
5 **Historic Courtroom, Courthouse Complex**
6 **Camden, North Carolina**

7
8 **MINUTES**

9
10 The regular meeting of the Camden County Board of Commissioners was held
11 on June 15th, 2015 in the Historic Courtroom, Camden, North Carolina. The
12 following Commissioners were present:

13
14 Chairman Michael McLain, Vice Chairwoman Sandra Duckwall;
15 Commissioners Garry Meiggs, Tom White and Clayton Riggs

16
17 Also attending were County Manager Michael Renshaw, and Clerk to the Board
18 Angela L. Wooten. Present for purposes of making a presentation(s) or providing
19 supporting information for agenda items were the following persons: Finance
20 Officer Stephanie Humphries, Parks and Recreation Director Tim White., Tax
21 administrator Kim Monton

22
23 **Regular Session, 7:00 P.M.**

24
25 Chairman Michael McLain called to order the June 15th, 2015 meeting of the
26 Camden County Board of Commissioners at 7:00 PM.

27
28 **Invocation and Pledge of Allegiance**

29
30 Commissioner Tom White gave the invocation and led those present in the
31 Pledge of Allegiance.

32
33
34 **Public Comments**

35
36 Steve Harris of 121 Shipyard Road in Camden came before the board with the
37 following comments:

- 38 • The repair at Academi was done with repair parts that were in the shop for
39 1 ½ years.

- 40 • Large metering systems have a bypass; therefore water supply would not
41 be affected during repair.
42 • Wet weather does not effect a water leak repair
43 • The sewer pump at the duck thru was disabled, not repaired. leaving only
44 one operational pump.
45
-
-

46
47 **Consideration of Agenda**
48

49 Chairman Michael McLain asked if there were any changes to the agenda.
50

51 Manager Renshaw noted the following changes to the agenda:

- 52 • Remove Consent Agenda Item 7.A. Draft Minutes

53
54 Commissioner Garry Meiggs made a motion to approve the agenda as amended.
55 The motion passed 5-0 with Chairman Michael McLain, Vice Chairwoman Sandra
56 Duckwall, Commissioner Garry Meiggs, Tom White and Clayton Riggs voting
57 aye; no Commissioner voting no; no Commissioners absent; and no
58 Commissioner not voting.
59

60
61 **Presentations**
62

63 ***Item 3.A - Dr. Mason Economic Improvement Council***
64

65 Dr. Landon Mason from the Economic Improvement Council will update the
66 Commissioners about the opportunities provided by the EIC to the residents of
67 Camden.

- 68
69 • Weatherization
70 • Community Services Block Grant
71 • Head Start
72 • Section 8 Housing

73
74
75 ***Item 3.B - County Tax Rate Review***
76

77 This being a revaluation year in which we saw decreasing property values, the
78 finance officer thought it would be helpful to layout the true effects of the
79 decrease in property value and the resulting property tax equalization. In trying
80 to equalize the tax values to be in line with market values, an adjustment to the
81 tax rate is needed to neutralize the revenue we would have lost from keeping the
82 previous rate. Typically, the values are not adjusted as significantly as they are
83 this revaluation period. While our tax rate is being adjusted .09/100, other
84 partnering counties saw rate increases in the double digits when adjusting for
85 revaluations performed after the housing bubble. The last valuation caused a
86 significant increase in values due to the housing boom and the result was a
87 significant decrease in the tax rate. While the tax rates needs to be adjusted for
88 the decrease in property values we are still not at the pre-housing boom rate of
89 \$.90/100. Even with the decrease in our tax base, we have been able to budget a
90 tax rate below the revenue neutral rate of 1.2 cents a savings to taxpayers of
91 \$218,358 (\$121,102/97,256). Many factors contribute to this but the major factor is
92 the minimal increase in our annual operating budget from 14-15 to 15-16.

93
94 The fund balance continues to be healthy allowing for savings that is being
95 passed on to our citizens. We are also in a position to begin using our county
96 resources to invest in infrastructure to provide improved service and economic
97 development. Our citizens have expressed excitement and approval of the recent
98 development such as the new Dollar General Store.

99
100 While self-sufficiency of the South Camden Water and Sewer needed to be
101 addressed with rate increases, it is important to recognize the fiscal responsibility
102 this represents. The Local Government Commission as well as the Governmental
103 Accounting Standards Board set standards that require using tax revenue to
104 improve county services and Enterprise revenue to improve water/sewer services.
105 Even though additional revenue may be needed in coming years, this year's
106 partial adjustment will bring additional revenue toward that standard while
107 minimizing the effect to customers.

108
109
110 ***Item 3.C - Water & Sewer Staffing***

111
112 The County Manager made a presentation on the need for the requested new
113 Water & Sewer Collection/Distribution staff position in the FY 2015-2016 annual
114 budget

117 **Old Business**

118

119 ***Item 4.A- Camden Youth Sports Programming***

120

121 The Parks & Recreation Advisory Board has recommended allowing the Camden
122 Youth League to operate a fall youth soccer program using existing field space
123 made available through the Facility Use Agreement between the County and
124 Camden County Public Schools.

125

126 Commissioner Tom White made a motion to approve the Youth Sports Program
127 as presented. The motion passed 5-0 with Chairman Michael McLain, Vice
128 Chairwoman Sandra Duckwall, Commissioner Garry Meiggs, Tom White and
129 Clayton Riggs voting aye; no Commissioner voting no; no Commissioners absent;
130 and no Commissioner not voting.

131

132 **Public Hearings**

133

134 ***Item 5.A - Camden County Capital Improvement Program***

135

136 Commissioner Garry Meiggs made a motion to go into public hearing for
137 Camden County Capital Improvement Program. The motion passed 5-0 with
138 Chairman Michael McLain, Vice Chairwoman Sandra Duckwall, Commissioner
139 Garry Meiggs, Tom White and Clayton Riggs voting aye; no Commissioner
140 voting no; no Commissioners absent; and no Commissioner not voting.

141

142 Chairman McLain asked if there were any comments from the public in regards
143 to the CIP.

144

145 On March 16th the board met in a work session to discuss the Capital
146 improvement Plan. Since the work session staff has included a funding plan for
147 each of projects listed as priorities in the plan.

148

149 **Projects added to the CIP**

150

- 151 • Wastewater treatment plan in the core area of the county
- 152 • Future Camden County High School
- 153 • Community Park in the South Mills Township

154

155 Chairman Michael McLain asked if there were any further comments from the
156 public regarding this issue. Hearing none, he called for a motion to close the
157 public hearing.

158

159 Commissioner Tom White made a motion to close the public hearing. The
160 motion passed 5-0 with Chairman Michael McLain, Vice Chairwoman Sandra
161 Duckwall, Commissioner Garry Meiggs, Tom White and Clayton Riggs voting
162 aye; no Commissioner voting no; no Commissioners absent; and no
163 Commissioner not voting.

164

165 As no one spoke in opposition during the public hearing, Commissioner Clayton
166 Riggs made a motion to add “Camden County Capital Improvement Program” as
167 New Business item 6.F. The motion passed 5-0 with Chairman Michael McLain,
168 Vice Chairwoman Sandra Duckwall, Commissioner Garry Meiggs, Tom White
169 and Clayton Riggs voting aye; no Commissioner voting no; no Commissioners
170 absent; and no Commissioner not voting.

171

172

173 **New Business**

174

175 ***Item 6.A - Monthly Tax Report – April***

176

**MONTHLY REPORT OF THE TAX ADMINISTRATOR TO THE
CAMDEN COUNTY BOARD OF COMMISSIONERS**

OUTSTANDING TAX DELINQUENCIES BY YEAR

<u>YEAR</u>	<u>REAL PROPERTY</u>	<u>PERSONAL PROPERTY</u>
2014	283,932.14	10,429.57
2013	98,955.05	8,744.82
2012	36,494.29	11,019.74
2011	20,848.32	8,157.68
2010	20,670.05	6,405.84
2009	7,571.42	6,069.27
2008	6,133.55	6,354.62
2007	6,133.10	3,814.64
2006	2,119.09	14,499.82
2005	1,690.71	26,514.92

177

CAMDEN COUNTY BOARD OF COMMISSIONERS
 Regular Meeting – June 15th, 2015

TOTAL REAL PROPERTY TAX UNCOLLECTED	481,437.46
TOTAL PERSONAL PROPERTY UNCOLLECTED	108,004.87
TEN YEAR PERCENTAGE COLLECTION RATE	96.13%
COLLECTION FOR 2015 vs. 2014	71,808.48% 96.47%
LAST 3 YEARS PERCENTAGE COLLECTION RATE	
2014	95.66%
2013	96.51%
2012	99.54%

THIRTY LARGEST UNPAID ACCOUNTS

SEE ATTACHMENT "A"

THIRTY OLDEST UNPAID ACCOUNTS

SEE ATTACHMENT "B"

EFFORTS AT COLLECTION IN THE LAST 30 DAYS
 ENDING April 2015
 BY TAX ADMINISTRATOR

- 10 NUMBER DELINQUENCY NOTICES SENT
- 11 FOLLOWUP REQUESTS FOR PAYMENT SENT
- 7 NUMBER OF WAGE GARNISHMENTS ISSUED
- 8 NUMBER OF BANK GARNISHMENTS ISSUED
- 12 NUMBER OF PERSONAL PHONE CALLS MADE BY TAX ADMINISTRATOR TO DELINQUENT TAXPAYER
- 9 NUMBER OF PERSONAL VISITS CONDUCTED (COUNTY OFFICES)
- 21 PAYMENT AGREEMENTS PREPARED UNDER AUTHORITY OF TAX ADMINISTRATOR
- 6 NUMBER OF PAYMENT AGREEMENTS RECOMMENDED TO COUNTY ATTORNEY
- 6 NUMBER OF CASES TURNED OVER TO COUNTY ATTORNEY FOR COLLECTION (I.D. AND STATUS)
- 6 REQUEST FOR EXECUTION FILES WITH CLERK OF COURTS
- 6 NUMBER OF JUDGMENTS FILED

178

179

Acct#	Parcel Number	Amount Due	Taxpayer Name	City	Property Address
02-1880-02-11	02-1880-02-11	1,111.11	WALTON ASSOCIATES	SOUTH HILLS	187 DUNN STREET SE
02-1880-02-12	02-1880-02-12	1,111.11	WALTON ASSOCIATES	SOUTH HILLS	187 DUNN STREET SE
02-1880-02-13	02-1880-02-13	1,111.11	WALTON ASSOCIATES	SOUTH HILLS	187 DUNN STREET SE
02-1880-02-14	02-1880-02-14	1,111.11	WALTON ASSOCIATES	SOUTH HILLS	187 DUNN STREET SE
02-1880-02-15	02-1880-02-15	1,111.11	WALTON ASSOCIATES	SOUTH HILLS	187 DUNN STREET SE
02-1880-02-16	02-1880-02-16	1,111.11	WALTON ASSOCIATES	SOUTH HILLS	187 DUNN STREET SE
02-1880-02-17	02-1880-02-17	1,111.11	WALTON ASSOCIATES	SOUTH HILLS	187 DUNN STREET SE
02-1880-02-18	02-1880-02-18	1,111.11	WALTON ASSOCIATES	SOUTH HILLS	187 DUNN STREET SE
02-1880-02-19	02-1880-02-19	1,111.11	WALTON ASSOCIATES	SOUTH HILLS	187 DUNN STREET SE
02-1880-02-20	02-1880-02-20	1,111.11	WALTON ASSOCIATES	SOUTH HILLS	187 DUNN STREET SE
02-1880-02-21	02-1880-02-21	1,111.11	WALTON ASSOCIATES	SOUTH HILLS	187 DUNN STREET SE
02-1880-02-22	02-1880-02-22	1,111.11	WALTON ASSOCIATES	SOUTH HILLS	187 DUNN STREET SE
02-1880-02-23	02-1880-02-23	1,111.11	WALTON ASSOCIATES	SOUTH HILLS	187 DUNN STREET SE
02-1880-02-24	02-1880-02-24	1,111.11	WALTON ASSOCIATES	SOUTH HILLS	187 DUNN STREET SE
02-1880-02-25	02-1880-02-25	1,111.11	WALTON ASSOCIATES	SOUTH HILLS	187 DUNN STREET SE
02-1880-02-26	02-1880-02-26	1,111.11	WALTON ASSOCIATES	SOUTH HILLS	187 DUNN STREET SE
02-1880-02-27	02-1880-02-27	1,111.11	WALTON ASSOCIATES	SOUTH HILLS	187 DUNN STREET SE
02-1880-02-28	02-1880-02-28	1,111.11	WALTON ASSOCIATES	SOUTH HILLS	187 DUNN STREET SE
02-1880-02-29	02-1880-02-29	1,111.11	WALTON ASSOCIATES	SOUTH HILLS	187 DUNN STREET SE
02-1880-02-30	02-1880-02-30	1,111.11	WALTON ASSOCIATES	SOUTH HILLS	187 DUNN STREET SE

180

Acct#	Parcel Number	Amount Due	Taxpayer Name	City	Property Address
02-1880-02-01	02-1880-02-01	1,111.11	WALTON ASSOCIATES	SOUTH HILLS	187 DUNN STREET SE
02-1880-02-02	02-1880-02-02	1,111.11	WALTON ASSOCIATES	SOUTH HILLS	187 DUNN STREET SE
02-1880-02-03	02-1880-02-03	1,111.11	WALTON ASSOCIATES	SOUTH HILLS	187 DUNN STREET SE
02-1880-02-04	02-1880-02-04	1,111.11	WALTON ASSOCIATES	SOUTH HILLS	187 DUNN STREET SE
02-1880-02-05	02-1880-02-05	1,111.11	WALTON ASSOCIATES	SOUTH HILLS	187 DUNN STREET SE
02-1880-02-06	02-1880-02-06	1,111.11	WALTON ASSOCIATES	SOUTH HILLS	187 DUNN STREET SE
02-1880-02-07	02-1880-02-07	1,111.11	WALTON ASSOCIATES	SOUTH HILLS	187 DUNN STREET SE
02-1880-02-08	02-1880-02-08	1,111.11	WALTON ASSOCIATES	SOUTH HILLS	187 DUNN STREET SE
02-1880-02-09	02-1880-02-09	1,111.11	WALTON ASSOCIATES	SOUTH HILLS	187 DUNN STREET SE
02-1880-02-10	02-1880-02-10	1,111.11	WALTON ASSOCIATES	SOUTH HILLS	187 DUNN STREET SE
02-1880-02-11	02-1880-02-11	1,111.11	WALTON ASSOCIATES	SOUTH HILLS	187 DUNN STREET SE
02-1880-02-12	02-1880-02-12	1,111.11	WALTON ASSOCIATES	SOUTH HILLS	187 DUNN STREET SE
02-1880-02-13	02-1880-02-13	1,111.11	WALTON ASSOCIATES	SOUTH HILLS	187 DUNN STREET SE
02-1880-02-14	02-1880-02-14	1,111.11	WALTON ASSOCIATES	SOUTH HILLS	187 DUNN STREET SE
02-1880-02-15	02-1880-02-15	1,111.11	WALTON ASSOCIATES	SOUTH HILLS	187 DUNN STREET SE
02-1880-02-16	02-1880-02-16	1,111.11	WALTON ASSOCIATES	SOUTH HILLS	187 DUNN STREET SE
02-1880-02-17	02-1880-02-17	1,111.11	WALTON ASSOCIATES	SOUTH HILLS	187 DUNN STREET SE
02-1880-02-18	02-1880-02-18	1,111.11	WALTON ASSOCIATES	SOUTH HILLS	187 DUNN STREET SE
02-1880-02-19	02-1880-02-19	1,111.11	WALTON ASSOCIATES	SOUTH HILLS	187 DUNN STREET SE
02-1880-02-20	02-1880-02-20	1,111.11	WALTON ASSOCIATES	SOUTH HILLS	187 DUNN STREET SE
02-1880-02-21	02-1880-02-21	1,111.11	WALTON ASSOCIATES	SOUTH HILLS	187 DUNN STREET SE
02-1880-02-22	02-1880-02-22	1,111.11	WALTON ASSOCIATES	SOUTH HILLS	187 DUNN STREET SE
02-1880-02-23	02-1880-02-23	1,111.11	WALTON ASSOCIATES	SOUTH HILLS	187 DUNN STREET SE
02-1880-02-24	02-1880-02-24	1,111.11	WALTON ASSOCIATES	SOUTH HILLS	187 DUNN STREET SE
02-1880-02-25	02-1880-02-25	1,111.11	WALTON ASSOCIATES	SOUTH HILLS	187 DUNN STREET SE
02-1880-02-26	02-1880-02-26	1,111.11	WALTON ASSOCIATES	SOUTH HILLS	187 DUNN STREET SE
02-1880-02-27	02-1880-02-27	1,111.11	WALTON ASSOCIATES	SOUTH HILLS	187 DUNN STREET SE
02-1880-02-28	02-1880-02-28	1,111.11	WALTON ASSOCIATES	SOUTH HILLS	187 DUNN STREET SE
02-1880-02-29	02-1880-02-29	1,111.11	WALTON ASSOCIATES	SOUTH HILLS	187 DUNN STREET SE
02-1880-02-30	02-1880-02-30	1,111.11	WALTON ASSOCIATES	SOUTH HILLS	187 DUNN STREET SE

181

CAMDEN COUNTY BOARD OF COMMISSIONERS
 Regular Meeting – June 15th, 2015

Roll#	Parcel Number	YTD14	YTD15	Taxpayer Name	City	Property Address
000042	0001704	420.11	420.11	ARDELIA YOUNG 2004	CAMDEN	489 HWY
000042	0001708	421.11	421.11	JOHN WATSON 1965	CAMDEN	489 HWY
000042	0001842	309.80	309.80	MARCO ANTONIO LAMBLICA	WILLOW	139 BEDFORD DR
000042	0001846	10.60	10.60	JOHN WATSON 1965	CAMDEN	489 HWY
000042	0001778	282.11	282.11	LOUIS B. WATSON 28	CAMDEN	489 HWY
000042	0001782	789.41	789.41	JOHN WATSON 1965	CAMDEN	489 HWY
000042	0001792	789.41	789.41	JOHN WATSON 1965	CAMDEN	489 HWY
000042	0001796	856.07	856.07	ANDERSON FUNDING COMPANY	WILLOW	139 BEDFORD DR
000042	0001800	856.07	856.07	ANDERSON FUNDING COMPANY	WILLOW	139 BEDFORD DR
000042	0001804	478.50	478.50	ANDERSON FUNDING COMPANY	WILLOW	139 BEDFORD DR
000042	0001808	445.40	445.40	ANDERSON FUNDING COMPANY	WILLOW	139 BEDFORD DR
000042	0001812	445.40	445.40	ANDERSON FUNDING COMPANY	WILLOW	139 BEDFORD DR
000042	0001816	445.40	445.40	ANDERSON FUNDING COMPANY	WILLOW	139 BEDFORD DR
000042	0001820	445.40	445.40	ANDERSON FUNDING COMPANY	WILLOW	139 BEDFORD DR
000042	0001824	445.40	445.40	ANDERSON FUNDING COMPANY	WILLOW	139 BEDFORD DR
000042	0001828	445.40	445.40	ANDERSON FUNDING COMPANY	WILLOW	139 BEDFORD DR
000042	0001832	445.40	445.40	ANDERSON FUNDING COMPANY	WILLOW	139 BEDFORD DR
000042	0001836	445.40	445.40	ANDERSON FUNDING COMPANY	WILLOW	139 BEDFORD DR
000042	0001840	445.40	445.40	ANDERSON FUNDING COMPANY	WILLOW	139 BEDFORD DR
000042	0001844	445.40	445.40	ANDERSON FUNDING COMPANY	WILLOW	139 BEDFORD DR
000042	0001848	445.40	445.40	ANDERSON FUNDING COMPANY	WILLOW	139 BEDFORD DR
000042	0001852	445.40	445.40	ANDERSON FUNDING COMPANY	WILLOW	139 BEDFORD DR
000042	0001856	445.40	445.40	ANDERSON FUNDING COMPANY	WILLOW	139 BEDFORD DR
000042	0001860	445.40	445.40	ANDERSON FUNDING COMPANY	WILLOW	139 BEDFORD DR
000042	0001864	445.40	445.40	ANDERSON FUNDING COMPANY	WILLOW	139 BEDFORD DR
000042	0001868	445.40	445.40	ANDERSON FUNDING COMPANY	WILLOW	139 BEDFORD DR
000042	0001872	445.40	445.40	ANDERSON FUNDING COMPANY	WILLOW	139 BEDFORD DR
000042	0001876	445.40	445.40	ANDERSON FUNDING COMPANY	WILLOW	139 BEDFORD DR
000042	0001880	445.40	445.40	ANDERSON FUNDING COMPANY	WILLOW	139 BEDFORD DR
000042	0001884	445.40	445.40	ANDERSON FUNDING COMPANY	WILLOW	139 BEDFORD DR
000042	0001888	445.40	445.40	ANDERSON FUNDING COMPANY	WILLOW	139 BEDFORD DR
000042	0001892	445.40	445.40	ANDERSON FUNDING COMPANY	WILLOW	139 BEDFORD DR
000042	0001896	445.40	445.40	ANDERSON FUNDING COMPANY	WILLOW	139 BEDFORD DR
000042	0001900	445.40	445.40	ANDERSON FUNDING COMPANY	WILLOW	139 BEDFORD DR
000042	0001904	445.40	445.40	ANDERSON FUNDING COMPANY	WILLOW	139 BEDFORD DR
000042	0001908	445.40	445.40	ANDERSON FUNDING COMPANY	WILLOW	139 BEDFORD DR
000042	0001912	445.40	445.40	ANDERSON FUNDING COMPANY	WILLOW	139 BEDFORD DR
000042	0001916	445.40	445.40	ANDERSON FUNDING COMPANY	WILLOW	139 BEDFORD DR
000042	0001920	445.40	445.40	ANDERSON FUNDING COMPANY	WILLOW	139 BEDFORD DR
000042	0001924	445.40	445.40	ANDERSON FUNDING COMPANY	WILLOW	139 BEDFORD DR
000042	0001928	445.40	445.40	ANDERSON FUNDING COMPANY	WILLOW	139 BEDFORD DR
000042	0001932	445.40	445.40	ANDERSON FUNDING COMPANY	WILLOW	139 BEDFORD DR
000042	0001936	445.40	445.40	ANDERSON FUNDING COMPANY	WILLOW	139 BEDFORD DR
000042	0001940	445.40	445.40	ANDERSON FUNDING COMPANY	WILLOW	139 BEDFORD DR
000042	0001944	445.40	445.40	ANDERSON FUNDING COMPANY	WILLOW	139 BEDFORD DR
000042	0001948	445.40	445.40	ANDERSON FUNDING COMPANY	WILLOW	139 BEDFORD DR
000042	0001952	445.40	445.40	ANDERSON FUNDING COMPANY	WILLOW	139 BEDFORD DR
000042	0001956	445.40	445.40	ANDERSON FUNDING COMPANY	WILLOW	139 BEDFORD DR
000042	0001960	445.40	445.40	ANDERSON FUNDING COMPANY	WILLOW	139 BEDFORD DR
000042	0001964	445.40	445.40	ANDERSON FUNDING COMPANY	WILLOW	139 BEDFORD DR
000042	0001968	445.40	445.40	ANDERSON FUNDING COMPANY	WILLOW	139 BEDFORD DR
000042	0001972	445.40	445.40	ANDERSON FUNDING COMPANY	WILLOW	139 BEDFORD DR
000042	0001976	445.40	445.40	ANDERSON FUNDING COMPANY	WILLOW	139 BEDFORD DR
000042	0001980	445.40	445.40	ANDERSON FUNDING COMPANY	WILLOW	139 BEDFORD DR
000042	0001984	445.40	445.40	ANDERSON FUNDING COMPANY	WILLOW	139 BEDFORD DR
000042	0001988	445.40	445.40	ANDERSON FUNDING COMPANY	WILLOW	139 BEDFORD DR
000042	0001992	445.40	445.40	ANDERSON FUNDING COMPANY	WILLOW	139 BEDFORD DR
000042	0001996	445.40	445.40	ANDERSON FUNDING COMPANY	WILLOW	139 BEDFORD DR
000042	0002000	445.40	445.40	ANDERSON FUNDING COMPANY	WILLOW	139 BEDFORD DR

182

183
 184
 185
 186
 187
 188
 189
 190
 191
 192

Commissioner Garry Meiggs made a motion to approve the Monthly Tax Report as presented by staff. The motion passed 5-0 with Chairman Michael McLain, Vice Chairwoman Sandra Duckwall, Commissioner Garry Meiggs, Tom White and Clayton Riggs voting aye; no Commissioner voting no; no Commissioners absent; and no Commissioner not voting.

Item 6.B - Budget - Ordinance No. 2015-06-02

CAMDEN COUNTY BOARD OF COMMISSIONERS
Regular Meeting – June 15th, 2015

Ordinance No. 2015-06-02
AN ORDINANCE OF
THE BOARD OF COUNTY COMMISSIONERS OF
CAMDEN COUNTY, NORTH CAROLINA,
RELATING TO THE FY 2015 – 2016 BUDGET

BE IT ORDAINED BY THE BOARD OF COMMISSIONERS OF CAMDEN COUNTY, NORTH CAROLINA:

ARTICLE I BUDGET ORDINANCE

This Ordinance hereby incorporates, in its entirety, this Budget for the County of Camden for FY 2015-2016, adopted by the Board of Commissioners on June 15, 2015. Said Ordinance may hereafter be referred to as the "Budget Ordinance".

ARTICLE II GENERAL FUND

SECTION 1 – Appropriations: The following amounts are hereby appropriated in the General Fund for the operation of county government and its activities for the fiscal year beginning July 1, 2015 and ending June 30, 2016 in accordance with the Budget Ordinance and the chart of accounts heretofore established for this county.

Governing Body	\$ 95,614
County Administration	214,667
Elections	133,404
Finance	201,862
Personnel	71,883
Tax Supervisor	404,850
Register of Deeds	202,714
Community Development/Planning	355,678
Inspections	125,300
Economic Development Commission	159,953
Building & Grounds	418,849
Sheriff	1,615,183
School Resource Officer (SRO)	65,405
Court Facilities	29,934
Jury Commission	118
Public Works Administration	114,107
Fleet Vehicles	10,000
Traffic	3,560
Solid Waste	646,413
Public Health	128,331
Extension	101,540
Legals	50,000
Parks & Recreation	261,180
DDJP (JCPC)	67,631
Senior Center	121,017
Non-Departmental	198,643
Museum	5,900

Court Facilities Fees	20,000
Alb. Comm. Nutrition Site	6,840
School Resource Officer	37,838
School Capital Reserve Fund for School Debt Service	1,005,321
Senior Center Grant	3,900
Fees and Permits:	
Register of Deeds Fees	101,500
Building Permits and Planning Fees	70,400
Land Use Fees	5,000
Leased Property	22,000
Tire Disposal Dist	16,000
White Goods Disposal Dist	5,000
Recyclables	12,000
Disposables Tax Distribution	5,000
Electronics Management	800
Cable Franchise Fee	75,000
Gun Permit Fees	15,000
Golf Cart Fees	240
Pet/Privilege Licenses	250
5 Cents Per Bottle Fees	3,600
Recreation Fees	19,500
Library Fees	2,600
Sales and Services:	
Jail Fees	3,000
Sheriff's Officer Fees	22,000
Sale of Fixed Assets	3,000
Fines & Forfeitures	80,000
911 Fees for GIS	30,000
Other:	
Sheriff's Department Grants & Donations	16,100
Wellness Grant	2,350
Interest	46,968
Miscellaneous	14,300
Appropriated Fund Balance	95,178
TOTAL GENERAL FUND	\$ 11,802,839

ARTICLE III SOUTH CAMDEN WATER/SEWER DISTRICT FUND

The following amounts are hereby appropriated in the South Camden Water/Sewer District Fund for the fiscal year beginning July 1, 2015 and ending June 30, 2016.

R/O Plant Operation Expenses	415,395
Waste Water Operation Expenses	407,901
Distribution Expenses	372,132
Debt Service	286,980
	\$1,482,408

Soil/Water Conservation	62,263
Capital Outlay/Debt Service	1,050,321
Youth Council	1,300
County Public Library	198,861
Special Appropriations:	
Albemarle Commission	6,613
Alb. Dist. Jail Operations	405,920
College of the Albemarle	40,000
Conservation/Forestry	55,422
Central Communications	251,213
Emergency Management	13,798
RC&D	750
Schools – Current Expense	2,072,942
Schools – Contribution to Capital Reserve	323,783
MLK Funding	300
Hopeline	2,000
Food Pantry/Bank	2,000
Social Services	325,000
EMS	485,000
CH&S Fire Commission Four Cents	243,453
CH&S Fire Truck Loan	219,500
South Mills Fire Commission Four Cents	145,570
4-H Insurance	53,004
Contingency	40,000
TOTAL GENERAL FUND	\$ 11,802,839

SECTION 2 – Revenues: It is estimated that the following revenues will be available in the General Fund for the fiscal year beginning July 1, 2015 and ending June 30, 2016.

Ad Valorem and Vehicle Taxes:	
Budget Year	\$6,764,220
Prior Years Summary	318,850
Penalties and Interest	50,000
House Bill 1779	500
Other Taxes and Licenses:	
State 1 cent Sales Tax	565,000
Local Sales Tax - Art. 40	425,000
Local Sales Tax - Art. 42	125,000
Unrestricted Intergovernmental:	
ABC Profits	35,000
Refuge Revenue Sharing	8,500
Beer and Wine Tax	41,500
Utilities Franchise Fees	625,000
Medicaid Hold Harmless	650,000
Restricted Intergovernmental:	
State Grants – JIDP	51,907
Soil/Water Funds	3,600
S/W Technician Grant	21,794
Capital Reserve & Transfer Tax for Capital Debt Service	376,283

It is estimated that the following revenues will be available in the South Camden Water/Sewer District Fund for the fiscal year beginning July 1, 2015 and ending June 30, 2016.

Sale of Water	987,750
Sewer Fees	106,597
Connection Fees	30,000
Miscellaneous	40,300
Fund Balance Appropriated	142,761
General Fund Contribution	175,000
	\$1,482,408

ARTICLE IV COURTHOUSE & SHILOH FIRE COMMISSION FUND

The following amounts are hereby appropriated in the Courthouse and Shiloh Fire Commission Fund for the fiscal year beginning July 1, 2015 and ending June 30, 2016.

General Expenses	200,275
Fire Truck	469,500
Department of Insurance Grant	60,000
Debt Service	56,003
	\$785,778

It is estimated that the following revenues will be available in the Courthouse and Shiloh Fire Commission Fund for the fiscal year beginning July 1, 2015 and ending June 30, 2016.

Fire Tax	60,863
4 Cent County Match	243,453
Leased Property	9,000
Grant	30,000
Interest Earnings	3,000
Fund Balance Appropriated	219,962
Co. Loan – Fire Truck	219,500
	\$785,778

ARTICLE V SOUTH MILLS FIRE COMMISSION FUND

The following amounts are hereby appropriated in the South Mills Fire Commission Fund for the fiscal year beginning July 1, 2015 and ending June 30, 2016.

General Expenses	92,475
Debt Service	104,047
	\$196,522

It is estimated that the following revenues will be available in the South Mills Fire Commission Fund for the fiscal year beginning July 1, 2015 and ending June 30, 2016.

Fire Tax	36,393
4 Cent County Match	145,570
Interest	2,000
Fund Balance Appropriated	12,559
	\$196,522

CAMDEN COUNTY BOARD OF COMMISSIONERS
 Regular Meeting – June 15th, 2015

ARTICLE VI SOCIAL SERVICES

The following amounts are hereby appropriated in the Social Services Fund for the fiscal year beginning July 1, 2015 and ending June 30, 2016.

Administrative Expenses	996,472
Public Assistance	334,159
	\$1,330,631

It is estimated that the following revenues will be available in the Social Services Fund for the fiscal year beginning July 1, 2015 and ending June 30, 2016.

County Appropriations	325,000
Fund Balance Appropriated	22,036
State/Federal Funds	983,595
	\$1,330,631

DSS Trust Fund Revenues	\$33,400
DSS Trust Fund Expenses	\$33,400

ARTICLE VII JOYCE CREEK DRAINAGE PROJECT FUND

The following amounts are hereby appropriated in the Joyce Creek Drainage Project Fund for the fiscal year beginning July 1, 2015 and ending June 30, 2016.

General Upkeep on project	45,200
Fund Reserve	5,512
	\$50,712

It is estimated that the following revenues will be available in the Joyce Creek Drainage Project Fund for the fiscal year beginning July 1, 2015 and ending June 30, 2016.

Watershed Improvement Fee	49,724
Miscellaneous	988
	\$50,712

ARTICLE VIII FEREBEE COURTHOUSE TRUST FUND

For purposes of summary only, the following amounts are hereby appropriated in the Nancy M. & H. C. Ferebee, III Courthouse Trust for the restoration of the 1847 Camden County Courthouse for the fiscal year beginning July 1, 2015 and ending June 30, 2016.

Fund Reserves	\$1,530
Trust Revenues	\$1,530

ARTICLE IX REVALUATION RESERVE FUND

The following amounts are hereby appropriated in the Revaluation Reserve Fund for the fiscal year beginning July 1, 2015 and ending June 30, 2016.

Reserved for Revaluation Expenses	\$240,230
Fund Balance Appropriated	\$240,230

ARTICLE X CAPITAL RESERVE FUND

The following amounts are hereby appropriated in the Capital Reserve Fund for the fiscal year beginning July 1, 2015 and ending June 30, 2016.

Debt Service	356,283
Capital Projects	182,500
Reserved	325,000
USDA Debt Reserve	488,300
	\$1,352,083

It is estimated that the following revenues will be available in the Capital Reserve Fund for the fiscal year beginning July 1, 2015 and ending June 30, 2016.

Land Transfer Tax Collections	300,000
Investment Earnings	20,000
County Contribution	325,000
Fund Balance Appropriated	707,083
	\$1,352,083

ARTICLE XI SCHOOL CAPITAL RESERVE FUND

The following amounts are hereby appropriated in the School Capital Reserve Fund for the fiscal year beginning July 1, 2015 and ending June 30, 2016.

Debt Service	694,038
HS Building Capital Outlay	150,000
Camden Plantation Funds for Capital Outlay	441,217
	\$1,285,255

It is estimated that the following revenues will be available in the School Capital Reserve Fund for the fiscal year beginning July 1, 2015 and ending June 30, 2016.

Local Option Sales Tax	350,000
Investment Earnings	6,000
Camden Plantation	150,000
County Contribution	323,783
Fund Balance Appropriated	455,472
	\$1,285,255

ARTICLE XII DISMAL SWAMP VISITOR CENTER FUND

The following amounts are hereby appropriated in the Dismal Swamp Visitor Center Fund for the purpose of operating the Center with funds received from NCDOT for the fiscal year beginning July 1, 2015 and ending June 30, 2016.

Center Operating Expenses	\$161,180
DOT Funds	142,857
Gift Shop Contribution	7,500
Tourism Authority Contribution	7,500
Fund Balance Appropriated	3,323
	\$161,180

The following amounts are hereby appropriated in the Dismal Swamp Gift Shop Fund for the fiscal year beginning July 1, 2015 and ending June 30, 2016.

Gift Shop Revenues	\$20,100
Gift Shop Expenses	\$20,100

ARTICLE XIII COMMUNITY PARK TRUST FUND

The following amounts are hereby appropriated in the Community Park Trust Fund for the upkeep and maintenance of the Community Park, Senior Trail, Dismal Swamp Bike Trail, Shiloh Landing and the One Mill Park Project for the fiscal year beginning July 1, 2015 and ending June 30, 2016.

Park Operations	\$3,050
Interest	1,500
Fund Balance Appropriated	1,550
	\$3,050

ARTICLE XIV REGISTER OF DEEDS AUTOMATION ENHANCEMENT AND PRESERVATION FUND

The following amounts are hereby appropriated in the Register of Deeds Automation Enhancement and Preservation Fund for the purpose of funding for computer and imaging technology for the fiscal year beginning July 1, 2015 and ending June 30, 2016.

Technology	\$9,100
Register of Deeds Technology Funds	4,000
Interest	100
Fund Balance Appropriated	5,000
	\$9,100

ARTICLE XV CODE ENFORCEMENT REVOLVING FUND

The following amounts are hereby appropriated in the Code Enforcement Revolving Fund for the fiscal year beginning July 1, 2015 and ending June 30, 2016.

Demolition Expenses	15,000
Special Assessments	3,000
	\$18,000

It is estimated that the following revenues will be available in the Code Enforcement Revolving Fund for the fiscal year beginning July 1, 2015 and ending June 30, 2016.

Fee Collection	3,000
Fund Balance Appropriated	15,000
	\$18,000

ARTICLE XVI WATER/SEWER UPGRADE FEE FUND

The following amounts are hereby appropriated in the Impact Fee Fund for the purpose of collecting funds from new construction projects which will have an impact on the infrastructure of Camden County for the fiscal year beginning July 1, 2015 and ending June 30, 2016.

Fund Reserve	22,000
Fees Collected	20,000
Interest	2,000
	\$22,000

ARTICLE XVII STORMWATER MANAGEMENT UTILITY FUNDS

At the May 5, 2014 Board of Commissioners meeting Ordinance No. 2014-05-01 was approved. This Ordinance established the South Mills Watershed, the Sawyer's Creek Watershed, the North River Watershed and the Shiloh Watershed and the parcel fee rates relating to each watershed. The billing and collection will be in the same manner as property taxes.

The following amounts are hereby appropriated for funding the programs designed to protect and manage water quality and quantity in the **South Mills Watershed Fund (Fund 36)** for the fiscal year beginning July 1, 2015 and ending June 30, 2016.

Watershed Expenses & Reserve	\$59,125
Estimated Interest & Fees Collected	\$59,125

The following amounts are hereby appropriated for funding the programs designed to protect and manage water quality and quantity in the **Sawyer's Creek Watershed Fund (Fund 37)** for the fiscal year beginning July 1, 2015 and ending June 30, 2016.

Watershed Expenses & Reserve	\$20,100
Estimated Interest & Fees Collected	\$20,100

CAMDEN COUNTY BOARD OF COMMISSIONERS
 Regular Meeting – June 15th, 2015

<p>The following amounts are hereby appropriated for funding the programs designed to protect and manage water quality and quantity in the North River Watershed Fund (Fund 38) for the fiscal year July 1, 2015 and ending June 30, 2016.</p> <table border="0"> <tr> <td>Watershed Expenses</td> <td>\$18,050</td> </tr> <tr> <td>Estimated Interest & Fees Collected</td> <td>\$18,050</td> </tr> </table> <p>The following estimated revenues will be available for funding the programs designed to protect and manage water quality and quantity in the Shiloh Watershed Fund (Fund 39) for the fiscal year beginning July 1, 2015 and ending June 30, 2016.</p> <table border="0"> <tr> <td>Watershed Expenses</td> <td>\$19,050</td> </tr> <tr> <td>Estimated Interest & Fees Collected</td> <td>\$19,050</td> </tr> </table> <p>ARTICLE XXVIII TOURISM DEVELOPMENT AUTHORITY</p> <p>The following amounts are hereby appropriated in the Tourism Development Authority budget for the fiscal year beginning July 1, 2015 and ending June 30, 2016.</p> <table border="0"> <tr> <td>General Expenses</td> <td>39,000</td> </tr> <tr> <td>Dismal Swamp Visitor Center</td> <td>7,500</td> </tr> <tr> <td></td> <td>\$46,500</td> </tr> <tr> <td>Occupancy Tax Collections</td> <td>20,000</td> </tr> <tr> <td>Interest Earnings</td> <td>500</td> </tr> <tr> <td>Appropriated Fund Balance</td> <td>26,000</td> </tr> <tr> <td></td> <td>\$46,500</td> </tr> </table> <p>ARTICLE XX TAX PENALTIES SCHOOL FUND</p> <p>The following amounts are hereby appropriated in the Tax Penalties School Fund budget for the fiscal year beginning July 1, 2015 and ending June 30, 2016.</p> <table border="0"> <tr> <td>School Current Expense</td> <td>\$3,850</td> </tr> </table> <p>It is estimate that the following revenues will be available in the Tax Penalties School Fund for the fiscal year beginning July 1, 2015 and ending June 30, 2016.</p> <table border="0"> <tr> <td>Tax Penalties</td> <td>3,750</td> </tr> <tr> <td>Interest on Investments</td> <td>100</td> </tr> <tr> <td></td> <td>\$3,850</td> </tr> </table> <p>ARTICLE XXII EDC PROJECT FUND</p> <p>The following amounts are hereby appropriated in the EDC Project Fund for the purpose of developing the ECO Industrial Park in South Mills for the fiscal year beginning July 1, 2015 and ending June 30, 2016.</p>	Watershed Expenses	\$18,050	Estimated Interest & Fees Collected	\$18,050	Watershed Expenses	\$19,050	Estimated Interest & Fees Collected	\$19,050	General Expenses	39,000	Dismal Swamp Visitor Center	7,500		\$46,500	Occupancy Tax Collections	20,000	Interest Earnings	500	Appropriated Fund Balance	26,000		\$46,500	School Current Expense	\$3,850	Tax Penalties	3,750	Interest on Investments	100		\$3,850	<table border="0"> <tr> <td>Capital Outlay</td> <td>500</td> </tr> <tr> <td>Economic Dev Incentive</td> <td>40,000</td> </tr> <tr> <td></td> <td>\$40,500</td> </tr> <tr> <td>Interest earned</td> <td>500</td> </tr> <tr> <td>Fund Balance Appropriated</td> <td>40,000</td> </tr> <tr> <td></td> <td>\$40,500</td> </tr> </table> <p>ARTICLE XXIII SCHOOL APPROPRIATIONS</p> <p>SECTION 1 – The appropriations to the Board of Education, first, shall be made from any such funds which are dedicated to the use of the schools, and secondly, shall be made from the general county fund revenues to the extent necessary to meet the approved appropriation.</p> <p>SECTION 2 – For purposes of summary only as the actual figures are contained in the Budget Ordinance, the total appropriation for Current Expense from the General Fund is \$2,072,942.</p> <p>SECTION 3 – Except as otherwise provided in this Budget Ordinance, this Budget Ordinance hereby incorporates by reference in its entirety the “PROPOSED BUDGET OF THE CAMDEN COUNTY BOARD OF EDUCATION FOR THE FISCAL YEAR BEGINNING JULY 1, 2015 and ENDING JUNE 30, 2016” as presented to the Board of Commissioners at their meeting in May 2015, and all language in said Proposed Budget is incorporated into this Ordinance as if it were included within the body of this Ordinance. Said Proposed Budget may hereafter be referred to as the “School Budget”. The county budget does not include any special appropriation for the supplement for teachers’ salaries. This will have to be included in the school budget.</p> <p>ARTICLE XXIV OTHER PROVISIONS</p> <p>SECTION 1 – The Camden County Budget Officer is hereby authorized to transfer appropriations within a fund as contained herein under the following conditions:</p> <ol style="list-style-type: none"> He may transfer amounts between objects of expenditure within a department except salary amounts without limitations. He may transfer amounts up to \$5,000 between departments of the same fund with an official report on such transfers at the next regular meeting of the Board of Commissioners. He may not transfer any amounts between funds or from any contingency appropriation within any fund. He will assign legal costs to departments based upon the legal issue involved. He is authorized to approve expenditures up to seven thousand dollars. 	Capital Outlay	500	Economic Dev Incentive	40,000		\$40,500	Interest earned	500	Fund Balance Appropriated	40,000		\$40,500
Watershed Expenses	\$18,050																																										
Estimated Interest & Fees Collected	\$18,050																																										
Watershed Expenses	\$19,050																																										
Estimated Interest & Fees Collected	\$19,050																																										
General Expenses	39,000																																										
Dismal Swamp Visitor Center	7,500																																										
	\$46,500																																										
Occupancy Tax Collections	20,000																																										
Interest Earnings	500																																										
Appropriated Fund Balance	26,000																																										
	\$46,500																																										
School Current Expense	\$3,850																																										
Tax Penalties	3,750																																										
Interest on Investments	100																																										
	\$3,850																																										
Capital Outlay	500																																										
Economic Dev Incentive	40,000																																										
	\$40,500																																										
Interest earned	500																																										
Fund Balance Appropriated	40,000																																										
	\$40,500																																										
<p>SECTION 2 – All legal outstanding encumbrances at June 30, 2015 are hereby carried forward and re-appropriated as an amendment to the budget for the fiscal year beginning July 1, 2015 and ending June 30, 2016.</p> <p>ARTICLE XXV TAX LEVY</p> <p>SECTION 1 – There is hereby levied at the rate of sixty-four cents (64 cents) per One Hundred Dollar (\$100) valuation of property listed for taxes as of January 1, 2015, for the purpose of raising the revenue listed in the General Fund, Article II, Section 2, of this Ordinance.</p> <p>SECTION 2 – There is hereby levied at the rate of four cents (4 cents) per One Hundred Dollar (\$100) valuation of property listed for taxes as of January 1, 2015, for the purpose of raising the revenue to equal the expenditures listed as CH&S Fire Commission Four Cents and South Mills Fire Commission Four Cents in the General Fund, Article II, Section 1, of this Ordinance.</p> <p>SECTION 3 – The rate of tax as shown in Section 1 and 2 above is based upon a total valuation of property for the purpose of taxation of \$961,124,336 and an estimated collection rate of ninety-six percent (96%) for real property and ninety-nine percent (99%) for vehicles.</p> <p>SECTION 4 – There is hereby levied a tax at the rate of one cent (1 cent) per One Hundred Dollar (\$100) valuation of property listed for the taxes as of January 1, 2015, located within the South Mills Fire Protection District for the purpose of raising the revenue listed in the South Mills Fire Commission Fund, Article V, of this Ordinance.</p> <p>SECTION 5 – The rate of tax as shown in Section 4 above is based upon a total valuation of property for the purpose of taxation of \$379,089,182 with an estimated collection rate of ninety-six point twenty-eight percent (96%).</p> <p>SECTION 6 – There is hereby levied at the rate of one cent (1 cent) per One Hundred Dollar (\$100) valuation of property listed for taxes as of January 1, 2015, located within the Courthouse-Shiloh Fire Protection District for the purpose of raising the revenue listed in the Courthouse-Shiloh Fire Commission Fund, Article IV, of the Ordinance.</p> <p>SECTION 7 – The rate of tax as shown in Section 6 above is based upon a total valuation of property for the purpose of taxation of \$633,992,417 and an estimated collection rate of ninety-six point twenty-eight percent (96%).</p>	<p>A public hearing on this Budget Ordinance was held on June 8, 2015.</p> <p>This Budget Ordinance was adopted on the 16th day of June, 2014 with Commissioners Sandra Duckwall, Garry Meiggs, Michael McLain, Clayton Riggs, and Randy Krainiak voting aye, and no Commissioner voting no.</p> <p>CAMDEN COUNTY BOARD OF COMMISSIONERS</p> <p>Michael McLain, Chair</p> <p>Sandra Duckwall, Vice-Chairman</p> <p>ATTEST:</p> <p>Clerk to the Board</p> <p>Michael R. Renshaw Budget Officer/Country Manager</p>																																										

193
 194
 195
 196

Commissioner Garry Meiggs made a motion to adopt the FY 2015-2016 Budget Ordinance No. 2015-06-02. The motion passed 5-0 with Chairman Michael

CAMDEN COUNTY BOARD OF COMMISSIONERS
Regular Meeting – June 15th, 2015

197 McLain, Vice Chairwoman Sandra Duckwall, Commissioner Garry Meiggs, Tom
198 White and Clayton Riggs voting aye; no Commissioner voting no; no
199 Commissioners absent; and no Commissioner not voting.

200

201 ***Item 6.C - Board Salaries - Resolution No. 2015-06-03***

202

<p>Resolution No. 2015-06-03</p> <p>A RESOLUTION OF THE CAMDEN COUNTY BOARD OF COMMISSIONERS ESTABLISH SALARIES AND COMPENSATION FOR VARIOUS BOARDS AND COMMISSIONS FOR FISCAL YEAR 2015-2016</p> <p>Whereas, the Camden County Board of Commissioners desires to provide reasonable compensation for service on various boards and commissions of the County;</p> <p>Now, Therefore, Be It Resolved that the Camden County Board of Commissioners meeting this <u>16th</u> day of June 2015 in Camden Village, Camden County, North Carolina does hereby establish the following salaries and compensation for the stated boards and commissions for the period beginning July 1, 2015 and ending June 30, 2016 (FY2015-2016).</p>	
<p>Section 1: BOARD OF ELECTIONS</p> <p>Chair \$50 / meeting with Board \$50 / Election Day, canvass day, and instruction day. Plus \$.575 / mile for travel</p> <p>Members \$40 / meeting \$40 / day on Election Day and canvass day Plus \$.575 / mile for travel</p> <p>Chief Judge \$150.00 / day for Election Day \$40 and canvass day, and instruction day \$20 for pick-up day \$.575 / mile for canvass day and instruction day.</p> <p>Judges \$20 for instruction day, Election Day at \$120.00 / day</p> <p>Assistants Election Day at \$100.00 / day, \$20 for instruction day</p>	<p>Section 3: PLANNING BOARD AND ZONING BOARD OF ADJUSTMENTS \$30.00 / meeting plus \$.575 / mile for travel</p> <p>Section 4: SOCIAL SERVICES BOARD Chairman \$35.00 / meeting plus \$.575 / mile for travel Members \$30.00 / meeting plus \$.575 / mile for travel</p> <p>Section 5: ALBEMARLE COMMISSION APPOINTMENT \$30.00 / meeting plus \$.575 / mile for travel and meal if required</p> <p>Section 6: AGING ADVISORY COUNCIL \$30.00 / meeting plus \$.575 / mile for travel and meal if required</p> <p>Section 7: RECREATION BOARD \$30.00 / meeting plus \$.575 / mile for travel</p> <p>Section 8: JURY COMMISSION (Does not meet FY14-15) \$ 7.25 / hour for hours worked compiling jury list</p> <p>Section 9: ECONOMIC DEVELOPMENT BOARD \$30.00 / meeting plus \$.575 / mile for travel</p> <p>Section 10: SENIOR CENTER BOARD \$30.00 / meeting</p> <p>Section 11: LIBRARY BOARD (Added 9/3/13) \$30.00 / meeting</p> <p>Section 12: AGRICULTURAL ADVISORY BOARD (Added 9/3/13) No Compensation.</p>
<p>Section 2: BOARD OF COMMISSIONERS</p> <p>Chair \$550.00 / month, plus \$.575 / mile for travel</p> <p>Vice-chair/ Member \$525.00 / month, plus \$.575 / mile for travel</p> <p>Commissioners shall receive a payment of \$150.00 / day for any meeting or day for travel to/from meeting, lasting more than four hours and out of the county (35 mile radius of the Courthouse). Special meetings and budget work sessions in addition to the two regularly scheduled Board of Commissioners meetings will be compensated \$75 and up to \$75 for attendance at other board meetings that they have been appointed to and not already compensated for by those boards.</p>	<p>ATTEST:</p> <p>_____ Angela L. Wooten Clerk to the Board</p> <p style="text-align: right;">(SEAL)</p> <p>_____ Chairman Michael McLain</p>

203

204

205 Commissioner Tom White made a motion to approve Resolution No. 2015-06-03
206 FY 2015-2016 Board Salaries. The motion passed 5-0 with Chairman Michael
207 McLain, Vice Chairwoman Sandra Duckwall, Commissioner Garry Meiggs, Tom
208 White and Clayton Riggs voting aye; no Commissioner voting no; no
209 Commissioners absent; and no Commissioner not voting.

210

211 ***Item 6.D- Fee Schedule for FY2015-2016***

212

CAMDEN COUNTY BOARD OF COMMISSIONERS
 Regular Meeting – June 15th, 2015



SCHEDULE OF FEES

FY 2015-2016

Public Hearing was held on June 8th, 2015

TABLE OF CONTENTS

Building Inspection/Planning	1
GIS Related Fee Schedule	5
Fee Schedule for Abatement of Property	6
Parks/Recreation Policies/Tees	7
Register of Deeds Schedule of Fees	8
Sheriff Department Fees	9
Pet Licenses	9
Senior Center Fees	10
Senior Trail Use Fees	11
Golf Cart Permits	13
Beer and Wine	13
South Camden Water Rate Schedule	14
South Camden Sewer Rate Schedule	15
Copies of Public Records	17
Public Library Fees	18
Watershed Fees	19
Related Information	20

**CAMDEN COUNTY
 BUILDING INSPECTIONS AND PLANNING DEPARTMENT
 PERMIT FEE SCHEDULE**

BUILDING PERMIT FEES

RESIDENTIAL, MODULAR, & COMMERCIAL CONSTRUCTION (UPTO 20,000 SQ. FEET)
 Minimum Required New Construction Permit Fees: (1) State Fee (Residential only) 10.00; (2) State Building Fee 0.25 cents per square foot; (3) Electrical Fee 0.15 cents per square foot; (4) Plumbing Fee 75.00; (5) Mechanical Fee 100.00; (6) Insulation Fee 75.00. Optional Fees: Temporary Power Pole 75.00. Commercial buildings are subject to other fees listed herein after.

State Fee Up to 20,000 Sq. Ft. \$0.25/Sq. Ft. Each Sq. Ft. over 20,000 \$0.15/Sq. Ft.
 Minimum Fee \$100.00 State Fee \$100.00

ELECTRICAL
 Residential Over 500 SQFT \$0.15/Sq. Ft. Service Repair \$75.00
 Minimum Fee \$75.00 Service Change \$75.00
 Temporary Service \$75.00 Mfg. Home Service \$75.00

PLUMBING
 Plumbing (New Install) \$75.00 Plumbing (Repair) \$75.00

MECHANICAL
 Minimum Fee \$100.00 Additional Units \$25.00
 Repair /Service Change \$75.00 Same Size Change Out \$0.00

INSULATION
 Minimum Fee \$75.00

NATURAL GAS PIPING (RESIDENTIAL & COMMERCIAL STRUCTURES)
 Minimum Fee (structures existing prior to 2005) \$3,500
 Minimum Fee (structures built on/after Jan 1, 2005) \$7,500

MANUFACTURED HOMES
 Singlewide: \$25,000 Doublewide: \$35,000 Tripwide: \$40,000

ADDITIONS - Includes Service Systems
 Up to 400 Square Feet \$0.50 Over 400 Square Feet \$0.75/Sq. Ft.

SWIMMING POOLS & SPAS
 In ground \$150.00 Above Ground \$50.00

DETACHED GARAGES, STORAGE, AND UTILITY BUILDINGS
 Minimum Fee/Under 400 Sq. Ft. \$75.00 Over 400 Sq. Ft. \$0.18/Sq. Ft.

CARPORT /POLE BARN/ POLE SHED
 Minimum Fee \$75.00 Over 834 Sq. Ft. \$0.095/Sq. Ft.

SINGLE UTILITY INSPECTION
 Trade Permit Minimum Fee \$50.00

Inspection & Planning Dept. Fee Schedule
 Revised July 1, 2014
 Page 1 of 4

SIGNS

36 Square Feet or Less \$0.00 17- 32 Sq. Ft. on One Side \$50.00
 Over 32 Sq. Ft. on One Side \$100.00 Electrical on Backstreet Sign \$50.00

DEMOLITION Fire, Safety, & EPA Regs
 Pre-inspection required for safety and hazardous materials and referral to proper channels if found. \$75.00

ALTERATIONS/ REPAIRS/ IMPROVEMENTS
 Up to \$5,000 Gross Retail \$75.00
 Over \$5,000 Gross Retail 50% Addition Fees

Alterations include work with an existing structure and upgrading existing services and do NOT include Addition, New Construction, (bring Power to structure not previously having power or New Service to existing buildings).

RENOVATION FEES 1/2 New Construction Fees
 Renovations

Fire Buildings are exempt UNLESS:
 • Any electrical installation is performed
 • Any portion of building is used for sleeping quarters
 • Building is used for business rather than personal use of owner and immediate family

MOVING OF ANY BUILDING WITHIN OR INTO THE COUNTY
 Minimum New Construction Fees

WIND ENERGY SYSTEMS
 Turbines \$2,000.00
 Rotorpoles \$100.00 each

COMMERCIAL PERMIT PRICES (extra)

MECHANICAL: Walk-in Cooler \$4,000 ea. Minimum Permit Fee \$75.00
 Commercial Cooking Hood \$4,000 ea. Per fire trap, or similar device \$5.00
 HVAC Fire dampers/smoke dampers \$3.00 ea. Per sprinkler head \$5.00

ELECTRICAL
 Electric duct heater \$10.00 ea.
 Temporary Service w/ Trailer \$100.00 ea.
 0-100 Each Receptacle/Switch/Platone \$75.00
 Each additional opening \$0.50 ea.
 Subpanel, main frame, generator \$2,000 ea.
 Fuel dispenser, "free-standing" parking lot light poles, manufacture of house pediments \$5.00 ea.
 Exhaust fan/water heater/BAC/Spr/Motors and machinery not specified \$50.00 ea.

Inspection & Planning Dept. Fee Schedule
 Revised July 1, 2014
 Page 2 of 4

CAMDEN COUNTY BOARD OF COMMISSIONERS
Regular Meeting – June 15th, 2015

COMMERCIAL PERMIT PRICES (continues - Continued)		Placed Unit Development	
GAS		Concept Plan	<u>Site Review</u>
Minimum Permit Fee	\$3,000	Master Plan and Amendments	\$1,000.00 (Includes Conditional Use Permit Fee)
Per outlet	\$5.00	Preliminary Plat Level	\$200.00 Per Lot
		Final Plat Level	\$50.00 Per Lot
NEGLIGENCE FEES		Commercial Site Plan Review	\$25.00
Inspection Negligence Fee (Applies To):	\$100.00	Stormwater Review Fees / Deposit:	
• Inspections called for but not ready		Major Subdivision (more than 5 acres)	\$6,000.00
• Skipping any applicable mandatory inspection		Minor Commercial Site Plan Review (3 acres or less)	\$3,700.00
• Re-inspections called for without first correcting discrepancies noted by inspector		Major Commercial Site Plan Review *** (more than 3 acres)	\$5,400.00
• Wrong sub-contractor other than on Trade Affidavit			
No Permit Negligence Fee (Applies To):	\$500.00		
• Building or Trade Related Activities performed without first obtaining and paying for a build in permit. Shall result in overall doubling of permit fee.			
BUILDING PERMIT FEES DUE AT TIME OF ISSUANCE		LAND DISTURBING ACTIVITY	
All Building Permit fees must be paid in full at time of permit issuance:		Fill Permit	\$50.00
• Applicants will be notified within 3-5 days after building permit application has been processed, reviewed, and approved. At that time permit fees are due.			
• No building permit will be issued without payment of permit fees due.			
LAND USE DEVELOPMENT FEES		NOTES:	
LAND USE DEVELOPMENT FEES DUE AT TIME OF APPLICATION		* Subject to refund in the case of a successful appeal of an order by the Board of Adjustment.	
• All fees for Land Use / Development MUST be paid in full at time of APPLICATION.		** For major subdivisions / PUDs, a fifteen dollar (\$15) credit per lot will be granted if the final plat is submitted both on Mylar in accordance with the Unified Development Ordinance and on diskette, in a format compatible (shape file / gis database) with the County's Geographic Information System (GIS) software.	
Zoning Permit	\$25.00	*** The County storm water review deposit / fee will be set up as an escrow wherein the applicant recovers any deposits in case of actual credit earned, or replenishes the escrow if costs drop below \$1000 prior to project approval.	
Conditional Use Permit	\$400.00		
Special Use Permit	\$400.00		
Temporary Use Permit	\$250.00		
Variance	\$300.00		
Ordinance Amendment Request	\$300.00		
Re-zoning Fee			
Up to 10 Acres	\$650.00		
Over 10 Acres	\$650.00 Plus \$10 Per Acre		
Interpretive Challenge / Appeal	\$250.00 *		
Subdivision Fee			
Major Subdivision			
Sketch Plan Level	\$150.00 Per Lot		
Preliminary Plat Level	\$200.00 Per Lot		
Final Plat Level	\$50.00 Per Lot**		
Minor Subdivision	\$200.00 Per Lot**		
Private Access Subdivision	\$200.00 Per Lot**		

Inspections & Planning Dept. Fee Schedule
Revised July 1, 2014
Page 3 of 4

Inspections & Planning Dept. Fee Schedule
Revised July 1, 2014
Page 4 of 4

Camden County

Fee Schedule for Sale of GIS Related Data

HARD COPY

Printer	Size	Black & White Price	Color Price
	8 1/2 x 11	\$0.50	\$1.00
	8 1/2 x 14	\$0.75	\$1.50
	11 x 17		\$5.00

Plotter	Size	Price
	Up to 36 x 48	\$10.00

ELECTRONIC MEDIA

Data Layers

Price: \$ 5.00 per CD
\$ 25.00 for first layer (shape file)
\$ 10.00 for each additional layer (shape file)

MrSid Cameraweed Digital Orthophotography

The entire set of digital orthophotography for the county.

Price: \$ 100.00

CUSTOMIZED GIS WORK

Any customized GIS projects will be charged a per hour fee of \$60.00/hr.

Camden County Street Maps \$5.00

Fee Schedule for Abatement of Property by County

Grass Cutting	\$300/acre
Grass Cutting	\$150/half acre
Debris Removal	\$500 plus tipping fees
Car Removal	**All Cost Incurred by County**
Administrative Cost	\$75.00 (This will be added to each Abatement)
Removal of Structure	**All Cost Incurred by County**

Fees are for Chapter 94 for Public Nuisances and Chapter 90 for Abandoned and Junk Motor Vehicles

This Fee Schedule is only if the County states the property. If a contractor is hired to perform any abatement then the cost will be the contracted price plus an Administrative fee.

Payment for abatement is due 30 days after the date of the abatement. If the fees are not paid then a Tax Lien will be applied to the property.

CAMDEN COUNTY BOARD OF COMMISSIONERS
 Regular Meeting – June 15th, 2015

Recreation Youth Sports Registration Fees:

Youth Volleyball and Basketball.....\$35.00

Maximum fee per household per season..... 70.00

Out of County additional registration fee..... 20.00

Recreation Youth Sports Sponsor Fee:

Team sponsor fee.....\$200.00
 (Fee pays for team Shirt and Individual Trophies)

Saturday Night Open Gym for Basketball

County residents.....\$1.00
 Out of County residents ... \$3.00

Thursday Night Open Gym for Adult Volleyball

County residents.....\$1.00
 Out of County residents.....\$3.00

REGISTER OF DEEDS FEES EFFECTIVE OCTOBER 1, 2011

Make checks payable to : Camden County Register of Deeds

Deeds of Trust & Mortgage	\$88 1st 15 pages \$4 each extra page
All other documents	\$26 1st 15 pages, \$4 each extra page
Plats	\$21 per plat
Plat copy page	\$1 per page, \$5 for certified copy per page
Right of Way/Highway	\$21 1st page \$2 each extra page
Multi-Documents	\$25 additional fee
Subsequent Documents with	\$25 additional fee
UCC 1 or 2 pages in writing	\$38
3-10 pages in writing	\$45 + \$2 each extra page
Copy of UCC statement	\$2 each page
Certified copies of Vital Records	\$10 each
Amended Birth & Death Certificate	\$10 ROD fee or \$15 NC Vital Records
Marriage License	\$60
Delayed Marriage or Birth Certificate	\$20 including 1 certified copy
Corrected Vital Records	\$10 including 1 certified copy
Legitimations	\$10
State Vital Record Search	\$10
State Vital Records for network access	\$24 1st copy, \$15 each extra copy
All Military Records or Satisfaction	No Fee
Notary Oath	\$10

CAMDEN COUNTY Sheriff's Department Fee Schedule

Office Fees:

Carry Concealed Permit	
New.....	\$90.00
Renew.....	\$75.00
Weapon Purchase Permit.....	\$5.00
Fingerprints.....	\$10.00
Civil Process Service	
In State.....	\$30.00
Out State.....	\$50.00
Out of County mental Patient Transport.....	\$150.00
Duplicate Copy of Photos.....	\$10.00
Dog/Cat Tag Fee	
Annual.....	\$5.00
Lifetime.....	\$30.00
Rental Fee.....	\$100.00

- Rental Policy for the Camden County Senior Center**
- The Camden County Board of Commissioners permits the use of the Camden Center after 3:00 p.m. Monday through Friday to governmental agencies and civic clubs and other clubs benefiting the county without charge provided the meeting or gathering is to conduct business pertaining to that agency or club.
 - Other non-profit agencies, clubs (civic clubs, dance clubs, bridge clubs), individuals and associations are permitted to use the Center after 5:00 p.m. Monday through Friday by paying the following fees:
 All Day..... \$100.00
 Evenings Only..... 50.00
 Use of the Kitchen..... 50.00
 - For-profit firms, agencies, etc. are permitted to use the Center after 5:00 p.m. by paying the following fee. A for-profit agency and/or firm would be Tupperware Products, Mary Kay Cosmetics, Bank of Currituck, Weight-Watchers, etc. If an individual or group is attempting to make a profit from a service or item to be provided or sold at the Senior Center, it will be considered a for-profit situation.
 Maximum of 2 hours use.....\$50.00
 Maximum of 4 hours use..... 65.00
 Maximum of 6 hours use.....100.00
 Maximum of 8 hours use.....120.00
 Use of the Kitchen..... 50.00
 - Rental Fees will not include the use of the Senior Citizens Craft Room, Exercise Room or the office space in the Center.
 - Alcoholic beverages are not permitted in the Senior Center or elsewhere on County property.
 - No confetti or like material is allowed in the Center. No streamers or like objects are allowed to be hung from the ceiling of the Center. All trash and garbage must be removed by the user.
 - Individuals signing the Use Agreement form will be required to provide a deposit in the amount of \$150 (made payable to Camden County) for the use of the Center and an additional \$150 (made payable to Camden County) for the use of the kitchen when obtaining the key to the Center. Fees are to be waived for Volunteer Fire Departments, Social Services Dept., Cooperative Extension Service, 4-H clubs, Homemakers' Club, Lions Club, Junior Women's Club, Runtans and others.
 - Deposits will be returned when the key to the Senior center is returned, providing the facilities are left in the condition in which they were found when the user arrived and nothing has been damaged or left improperly cleaned and all furnishings and furniture have been returned to their original places.

CAMDEN COUNTY BOARD OF COMMISSIONERS
 Regular Meeting – June 15th, 2015

Resolution No. 2001-6-3

A RESOLUTION OF THE BOARD OF COUNTY COMMISSIONERS OF CAMDEN COUNTY, NORTH CAROLINA, ESTABLISHING THE FEE FOR USE OF THE SENIOR TRAIL.

Whereas, the County Commissioners may establish a fee for the use of the Senior Trail;

Whereas, such fees shall reimburse the county for expenses incurred and provide funding for the long-term maintenance of the Senior Trail;

Now, Therefore, Be It Resolved by the Board of County Commissioners meeting this 4 day of June, 2011, in Camden, North Carolina, does hereby establish a fee schedule as follows for the use of the Senior Trail.

A. For events not requiring the provision of any chairs or other equipment, the fee shall be one hundred dollars (\$100.00) and such fee shall be in addition to any other fees required under this schedule.

B. For events requiring electricity, the fee shall be ten dollars (\$10.00) per hour and such fee shall be in addition to any other fee required under this schedule.

Be It Further Resolved that the county manager shall collect a deposit in amount equal to the amount of the fee charged above.

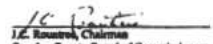
 J.C. Rowland, Chairman
 Camden County Board of Commissioners

ATTEST:

 Carl Chason
 Clerk to the Board

Any person not invited to the special event shall be trespassing and shall be subject to the same penalties as a trespasser under Section 1. of this Ordinance.

- The county manager shall develop an application for special events on the Senior Trail and each person requesting a special event to be held on the Senior Trail shall submit an application to the county manager or his designated representative. Such application shall include a signed and notarized statement indemnifying and holding harmless the County, its employees, and agents from any and all injuries or damages arising out of the special event and the use of the Senior Trail.
- The applicant shall clean and repair the Senior Trail to the same condition it was prior to the special event. If the Senior Trail is not cleaned or repaired back to the pre-event condition, the county manager shall first use any deposit to reimburse the county for the cost of any cleaning or repairs and, if such deposit is not sufficient to reimburse the county for the cleaning and repairs, the county manager shall direct the county attorney to take any necessary actions in court or otherwise to collect the amount required to reimburse the county for the cost of cleaning and repair plus any administrative and legal costs incurred while trying to obtain the reimbursement due to the county.
- The county manager may deny any application if, in his opinion, the event would be injurious to the Senior Trail. Any person denied use of the Senior Trail by the county manager may appeal such decision to the Board of County Commissioners at their next regular meeting following the date of the county manager's denial.
- The county manager or his designated representative may establish a deadline for the submission of applications and he shall make his decision within a reasonable period of time following submission of an application. Such decision shall be made in writing and given to the applicant.
- The county manager or his designated representative shall collect a fee for the use of the Senior Trail and a deposit for any possible damage. Such fee and deposit shall be collected at the time when the application is submitted. The fee shall be established by resolution of the county commissioners. The deposit shall be equal to the fee. Revenues received from the fee shall first be used to reimburse the county for any expenses incurred due to the special event, and any remaining fee revenue shall be deposited into the Senior Trail Trust Fund.
- The county manager or his designated representative shall return the deposit to the applicant following the event and after inspection. The deposit shall be reduced by an amount equal to any costs incurred by the county for cleaning up after the special event or making any repairs caused by the event or participants in the event.

<p style="text-align: center;">Fees collected at the Camden County Tax Office</p> <p style="text-align: center;">Golf Cart Permits</p> <p>Annual Fee.....\$ 20.00</p> <p>Late Listing Fee (for sticker)..... 50.00</p> <p>Non-Compliance.....150.00</p> <p style="text-align: center;">BEER AND WINE FEES</p> <p style="text-align: center;">(License period: May 1 through April 30 each year)</p> <p>Every person engaged in the business of selling beer and wine in the following amounts:</p> <p>Beer at retail</p> <p>"Off premises".....\$5.00</p> <p>"On premises".....\$15.00</p> <p>Beer "on and off Premises".....\$20.00</p> <p>Wine at retail</p> <p>"Off premises"..... \$10.00</p> <p>"On premises".....\$15.00</p> <p>Wine "on and off premises".....\$25.00</p> <p>Beer and Wine</p> <p>Beer and Wine "off premises".....\$15.00</p> <p>Beer and Wine "on premises".....\$30.00</p> <p>Beer/wine "on & off premises".....\$45.00</p>	<p style="text-align: center;">South Camden Water Rates (effective July 1, 2015)</p> <p>Water Tap Fees:</p> <table border="0" style="width: 100%;"> <tr> <td>¾ inch</td> <td>\$4,000.00</td> <td>4 inch</td> <td>\$7,000.00</td> </tr> <tr> <td>1 inch</td> <td>\$4,500.00</td> <td>6 inch</td> <td>\$8,000.00</td> </tr> <tr> <td>2 inch</td> <td>\$5,000.00</td> <td>6 inch five svc</td> <td>\$4,000.00</td> </tr> <tr> <td>3 inch</td> <td>\$6,000.00</td> <td>Hwy158/Bore</td> <td>\$2,000.00</td> </tr> </table> <p>Water Charges: 0-2000 gal. \$24.00 per month</p> <p>Additional Usage:</p> <table border="0" style="width: 100%;"> <tr> <td>2001-5000 gal.</td> <td>\$5.50 per 1,000 gal</td> </tr> <tr> <td>5001-10,000</td> <td>\$6.00 per 1,000 gal</td> </tr> <tr> <td>10,001-15,000</td> <td>\$6.60 per 1,000 gal</td> </tr> <tr> <td>15,001-20,000</td> <td>\$7.20 per 1,000 gal</td> </tr> <tr> <td>20,001 and up</td> <td>\$7.80 per 1,000 gal</td> </tr> </table> <p>Local Govt/Board of Education same as above</p> <p>Bulk Water \$6.06 per 1,000 gal</p> <p>Fire Service (sprinkler systems) \$24.00 per month</p> <p>Commercial master meter accounts: charged at the above rates per unit served.</p> <p>Deposits:</p> <p>Rent deposit: \$200.</p> <p>Fire Hydrant Meter: \$300.</p> <p>Charges and Fees:</p> <p>Open/reopen/transfer acct. \$15.00</p> <p>Reread meter/our read correct \$15.00</p> <p>Reread meter/our read incorrect: no charge</p> <p>Reconnection Fee: (if not paid by 8am on disconnection day)</p> <p>7am-3:15pm \$35.00</p> <p>3:16-5:00pm \$60.00</p> <p>Late payment penalty: \$10.00</p> <p>Non Sufficient Funds: \$25.00</p> <p>Meter Tampering fee: \$200.00</p> <p>Turn off/Turn off fee per occurrence: \$15.00</p> <p>Meter testing fee: if accurate \$15.00</p> <p>No chg if more than 2.5% inaccurate</p> <p>*effective June 2009</p>	¾ inch	\$4,000.00	4 inch	\$7,000.00	1 inch	\$4,500.00	6 inch	\$8,000.00	2 inch	\$5,000.00	6 inch five svc	\$4,000.00	3 inch	\$6,000.00	Hwy158/Bore	\$2,000.00	2001-5000 gal.	\$5.50 per 1,000 gal	5001-10,000	\$6.00 per 1,000 gal	10,001-15,000	\$6.60 per 1,000 gal	15,001-20,000	\$7.20 per 1,000 gal	20,001 and up	\$7.80 per 1,000 gal
¾ inch	\$4,000.00	4 inch	\$7,000.00																								
1 inch	\$4,500.00	6 inch	\$8,000.00																								
2 inch	\$5,000.00	6 inch five svc	\$4,000.00																								
3 inch	\$6,000.00	Hwy158/Bore	\$2,000.00																								
2001-5000 gal.	\$5.50 per 1,000 gal																										
5001-10,000	\$6.00 per 1,000 gal																										
10,001-15,000	\$6.60 per 1,000 gal																										
15,001-20,000	\$7.20 per 1,000 gal																										
20,001 and up	\$7.80 per 1,000 gal																										

CAMDEN COUNTY BOARD OF COMMISSIONERS
 Regular Meeting – June 15th, 2015

South Camden Sewer Schedule
 (effective July 1, 2015)

Sewer Base Fee:

Residential	\$27.00 0-2,000 gallons
Commercial	\$37.00 0-2,000 gallons
Apartments & Townhouses	\$27.00 0-2,000 gallons

Additional Fees:

Residential	\$6.50 each additional 1,000 gallons
Commercial	\$7.50 each additional 1,000 gallons
Apartments & Townhouses	\$6.50 each additional 1,000 gallons

High Strength: \$9.50 each additional 1,000 gallons
 School, Day Care, Hospitals, Nursing Homes, Laundromats, Restaurants, Doctors, Dentists, Beauty Shops, Grocery Store, Convenient Store, Funeral Homes, Car Washes, Dry Cleaners

Commercial: Fees are based on water meter size
 Cost of sewer connection (low pressure main) with ¾ inch water service-\$8300.
 Cost of sewer connection (4" gravity connection)- \$ 3500.
 The cost of sewer connection with larger than ¾ inch water service will be the responsibility of the owner, with the possibility of capacity fee being paid over time of 3-5 yrs. with no interest.

Sewer Capacity Fees

¾ inch	\$ 7,400.
1 inch	\$10,500.
2 inch	\$15,000.
3 inch	\$24,000.
4 inch	\$36,000.
6 inch	\$42,000.
8 inch	\$48,000.
10 inch	\$54,000.
12 inch	\$60,000.

South Camden Sewer Schedule
 (effective July 1, 2015)

Residential Sewer: Approved for failing systems only.

***Parts and labor:**

For changing service size, location, or repairs for damage to the districts property.

*Parts are calculated at current price of materials due to the fluctuation of the market plus 20%.

***Labor:**

\$35 per man per hour
 \$75 per hour for backhoe
 \$10 per foot for bores up 2"

*Repairs requiring contracted labor will be charged at invoice cost.

Fines for Violation of Fats, Oil and Grease Control Ordinance

Offense	Minor Violations			
	1 st Offense	2 nd Offense	3 rd Offense	4 th Offense & Up
Failure to submit records	Warning	\$100	\$150	\$500
Inspection hindrance	Warning	\$100	\$150	\$500
Failure to maintain on-site records	Warning	\$100	\$150	\$500
Failure to meet sample standards	Warning	\$100	\$150	\$500
Offense	Moderate Violations			
	1 st Offense	2 nd Offense	3 rd Offense	4 th Offense & Up
Failure to maintain interceptors in proper working order	\$150	\$300	\$500	\$1,000
Failure to clean out interceptor every 30 days	\$150	\$300	\$500	\$1,000
Offense	Major Violations			
	Source of sewer blockage (minimum) \$500 and not more than \$10,000 plus cost of cleaning lines			
	Source of sanitary sewer overflow (minimum) \$1,000 plus cost of cleaning lines			
Falsification of records		\$1,000		
*updated August 2, 2010				

CAMDEN COUNTY
 Public Records
 Fee Schedule

Copy Fees:

Public Records (Black/White)

8 1/2" x 11" and 8 1/2" x 14"	\$.15/page
With printed pictures	\$.50/page
11" x 17"	\$.50/page

Public Records (Color)

8 1/2" x 11" with pictures	\$.50/page
----------------------------	-------------

*Consent not required to create a public record that is not already in existence. However, the municipality may elect to create the record if it determines that the record will provide an ongoing benefit to the county and/or its citizens.

CAMDEN COUNTY
 Public Library
 Fee Schedule

Copy Fees:

8 1/2" x 11" and 8 1/2" x 14" (Black/White)	\$.30/page
8 1/2" x 11" and 8 1/2" x 14" (Color)	\$.25/page
11" x 17" (Black/White)	\$.20/page
11" x 17" (Color)	\$.50/page
Intercom Fee	\$.20/page
Issue Library Loan	\$2.50
Processing	\$10.00

CAMDEN COUNTY BOARD OF COMMISSIONERS
 Regular Meeting – June 15th, 2015

Ratio		40					
North River Watershed				Individual Parcel Fee			
	#	Rate	\$	#	\$		
FCPA Parcels	1,170	\$0.64	\$748.80	1	\$0.64		
GA net acres	28,476	\$0.25	\$7,119.00	1	\$0.25		
ERU units	1,037	\$10.00	\$10,370.00	1	\$10.00		
Project Revenue				\$17,489.00		\$10.89	
Total Watershed Revenue				\$18,237.80			
Sawyer's Creek Watershed				Individual Parcel Fee			
	#	Rate	\$	#	\$		
FCPA parcels	762	\$0.64	\$487.68	1	\$0.64		
GA net acres	9,436	\$0.25	\$2,359.00	1	\$0.25		
ERU units	1,969	\$10.00	\$19,690.00	1	\$10.00		
Project Revenue				\$22,049.00		\$10.89	
Total Watershed Revenue				\$22,536.68			
Shiloh Watershed Revenue				Individual Parcel Fee			
	#	Rate	\$	#	\$		
FCPA parcels	2,394	\$0.64	\$1,532.16	1	\$0.64		
GA net acres	17,765	\$0.25	\$4,441.25	1	\$0.25		
ERU units	1,397	\$10.00	\$13,970.00	1	\$10.00		
Project Revenue				\$18,413.25		\$10.89	
Total Watershed Revenue				\$19,943.41			
South Mills Watershed Revenue				Individual Parcel Fee			
	#	Rate	\$	#	\$		
FCPA parcels	2,917	\$0.64	\$1,866.88	1	\$0.64		
GA net acres	73,345	\$0.32	\$23,470.40	1	\$0.32		
ERU units	3,414	\$12.80	\$43,699.20	1	\$12.80		
Joyce Creek Project			\$50,000.00				
Other Project Revenue			\$17,169.60				
Total Watershed Revenue				\$69,036.48		\$13.76	
		Parcels	ERUs	Net Acres			
North River		1,170	1,037	28,476			
Sawyer's Creek		762	1,969	9,436			
Shiloh		2,394	1,397	17,765			
South Mills		2,917	3,414	73,345			
		7,343					

CAMDEN COUNTY
 Fee Schedule

Continuing authority of commission

Nothing contained in the provisions of this schedule shall be construed to prevent the County Board of Commissioners from imposing, from time to time as it may see fit, such license taxes as are not specifically defined or included in this schedule, or from increasing or decreasing the amount of any fee when not in conflict with State or Federal law.

Same-False statements

Any person who willfully makes a false statement on any fee application shall be guilty of a misdemeanor.

The forgoing instrument was duly approved and adopted at a meeting of the Camden County Board of Commissioners, said meeting date June 15th, 2015.

X

Angela L. Wooten
 Clerk to the Board

(SEAL)

X

Michael McLain, Chairman
 Camden County Board of Commissioners

213
 214
 215
 216
 217
 218
 219
 220
 221
 222

Commissioner Tom White made a motion to approve the FY 2015-2016 Schedule of Fees. The motion passed 5-0 with Chairman Michael McLain, Vice Chairwoman Sandra Duckwall, Commissioner Garry Meiggs, Tom White and Clayton Riggs voting aye; no Commissioner voting no; no Commissioners absent; and no Commissioner not voting.

Item 6.E - Set the County tax rate for FY2015-2016

CAMDEN COUNTY BOARD OF COMMISSIONERS
 Regular Meeting – June 15th, 2015

TO: CAMDEN COUNTY BOARD OF COMMISSIONERS

THE FOLLOWING IS THE ESTIMATED PROPERTY VALUE OF CAMDEN COUNTY:

	<u>Real</u>	<u>Personal</u>	<u>Vehicles</u>	<u>Total</u>
South Mills	341,490,940	11,502,456	26,095,786	379,089,182
Courthouse	351,336,480	18,580,167	34,276,022	404,192,669
Shiloh	209,744,722	5,910,524	14,144,502	229,799,748
Subtotal of County				1,013,081,599
Estimated Utilities	2,092,664(cell towers) 20,506,383(2014 utilities)			22,559,047
Total of County				1,035,640,646

FROM Lisa S. Anderson 10-10-15
 LISA S. ANDERSON (TAX ADMINISTRATOR) DATE

TAX RATE COUNTY .68 FIRE .01 TOTAL = .69

Joyce Creek District	<u>Real</u>	<u>Personal</u>	<u>Vehicles</u>	<u>Total</u>
	196,981,141	5,010,131	17,654,182	219,645,454

JOYCE CREEK WATERSHED IMPROVEMENT TAX 0

 P. MICHAEL MCLAIN, CHAIRMAN DATE

223
 224
 225
 226
 227
 228
 229
 230
 231
 232
 233
 234
 235
 236
 237
 238
 239

Commissioner Clayton Riggs made a motion to approve the county tax rate for FY 2015-2016. The motion passed 5-0 with Chairman Michael McLain, Vice Chairwoman Sandra Duckwall, Commissioner Garry Meiggs, Tom White and Clayton Riggs voting aye; no Commissioner voting no; no Commissioners absent; and no Commissioner not voting.

Item 6.F- Camden County Capital Improvement Program

Commissioner Clayton Riggs made a motion to accept the Capital Improvement plan as presented by staff. The motion passed 5-0 with Chairman Michael McLain, Vice Chairwoman Sandra Duckwall, Commissioner Garry Meiggs, Tom White and Clayton Riggs voting aye; no Commissioner voting no; no Commissioners absent; and no Commissioner not voting.

Consent Agenda

240
 241
 242
 243

The County Manager requested to remove item 7.A Draft minutes.

CAMDEN COUNTY BOARD OF COMMISSIONERS
Regular Meeting – June 15th, 2015

244
245 Commissioner Clayton Riggs made a motion to approve the consent agenda as
246 amended. The motion passed 5-0 with Chairman Michael McLain, Vice
247 Chairwoman Sandra Duckwall, Commissioner Garry Meiggs, Tom White and
248 Clayton Riggs voting aye; no Commissioner voting no; no Commissioners absent;
249 and no Commissioner not voting.

250

251

252 **Consent Agenda**

253

254 **Item 7.A - Draft Minutes – 2015-03-16 BOC CIP**

255

256 Removed

257

258 **Item 7.B - Budget Amendments – BA024**

259

ACCT NUMBER	DESCRIPTION OF ACCT	AMOUNT	
		INCREASE	DECREASE
106900-512900	Central Communication	\$11,500.00	
106900-565100	CH&S VFD 4 Cents	\$10,500.00	
106900-568100	SM VFD 4 Cents	\$10,500.00	
104100-504100	Attorney Fees		\$10,000.00
104700-504110	OLF		\$10,000.00
109990-500000	Contingency		\$12,500.00

This Budget Amendment is made to increase allocation for Central Communications expenses and 4 Cent VFD Tax Match.

This will result in a decrease of \$12,500.00 in the Contingency of the General Fund.

Balance in Contingency \$11,000.00

260

261

262 **Item 7.C - Tax Collection Report**

263

CAMDEN COUNTY BOARD OF COMMISSIONERS
 Regular Meeting – June 15th, 2015

Account	Amount	Account	Amount	Account	Amount
001000	16,803.06	002000	19,211.67	003000	10,192.52
004000		005000		006000	
007000		008000		009000	
010000		011000		012000	
013000		014000		015000	
016000		017000		018000	
019000		020000		021000	
022000		023000		024000	
025000		026000		027000	
028000		029000		030000	
031000		032000		033000	
034000		035000		036000	
037000		038000		039000	
040000		041000		042000	
043000		044000		045000	
046000		047000		048000	
049000		050000		051000	
052000		053000		054000	
055000		056000		057000	
058000		059000		060000	
061000		062000		063000	
064000		065000		066000	
067000		068000		069000	
070000		071000		072000	
073000		074000		075000	
076000		077000		078000	
079000		080000		081000	
082000		083000		084000	
085000		086000		087000	
088000		089000		090000	
091000		092000		093000	
094000		095000		096000	
097000		098000		099000	
100000		101000		102000	
103000		104000		105000	
106000		107000		108000	
109000		110000		111000	
112000		113000		114000	
115000		116000		117000	
118000		119000		120000	
121000		122000		123000	
124000		125000		126000	
127000		128000		129000	
130000		131000		132000	
133000		134000		135000	
136000		137000		138000	
139000		140000		141000	
142000		143000		144000	
145000		146000		147000	
148000		149000		150000	
151000		152000		153000	
154000		155000		156000	
157000		158000		159000	
160000		161000		162000	
163000		164000		165000	
166000		167000		168000	
169000		170000		171000	
172000		173000		174000	
175000		176000		177000	
178000		179000		180000	
181000		182000		183000	
184000		185000		186000	
187000		188000		189000	
190000		191000		192000	
193000		194000		195000	
196000		197000		198000	
199000		200000		201000	
202000		203000		204000	
205000		206000		207000	
208000		209000		210000	
211000		212000		213000	
214000		215000		216000	
217000		218000		219000	
220000		221000		222000	
223000		224000		225000	
226000		227000		228000	
229000		230000		231000	
232000		233000		234000	
235000		236000		237000	
238000		239000		240000	
241000		242000		243000	
244000		245000		246000	
247000		248000		249000	
250000		251000		252000	
253000		254000		255000	
256000		257000		258000	
259000		260000		261000	
262000		263000		264000	
265000		266000		267000	
268000		269000		270000	
271000		272000		273000	
274000		275000		276000	
277000		278000		279000	
280000		281000		282000	
283000		284000		285000	
286000		287000		288000	
289000		290000		291000	
292000		293000		294000	
295000		296000		297000	
298000		299000		300000	

264
 265
 266
 267

Item 7.D - Tax Authorization to Collect (Aug Renewals)

COUNTY OF CAMDEN

TO: The Tax Administrator of Camden County August Ren. Due 9/15/15 (NEW SYSTEM)

You are hereby authorized, empowered, and commanded to collect the taxes set forth in the tax records filed in the office of the Tax Administrator and in the tax receipts herewith delivered to you, in the amounts and from the taxpayers likewise therein set forth. Such taxes are hereby declared to be a first lien upon personal property of the respective taxpayers in the County of Camden, and this order shall be a full and sufficient authority to direct, require, and enable you to levy on and sell personal property of such taxpayers for and on account thereof, in accordance with the law.

SOUTH MILLS	COURTHOUSE	SHILOH	TOTAL
16,803.06	19,211.67	10,192.52	46,207.25

268
 269
 270
 271

Item 7.E - Elder Abuse Awareness Proclamation

CAMDEN COUNTY BOARD OF COMMISSIONERS
Regular Meeting – June 15th, 2015

VULNERABLE ADULT AND ELDER ABUSE
AWARENESS MONTH IN THE COUNTY OF CAMDEN - JUNE 2015

WHEREAS, each year, more than two million vulnerable and older adults are victims of abuse, neglect, and exploitation, and research has shown that older adults who are abused, neglected and exploited are three times more likely to die within ten years than those who are not; and

WHEREAS, according to national statistics, elder abuse is grossly under reported because vulnerable and older adults who are being abused find it very difficult to tell anyone due to shame and fear; and

WHEREAS, in 2014 there were almost 23,000 reports of abuse, neglect or exploitation of vulnerable and older adults made to North Carolina's 100 county departments of social services not only by doctors and other professionals but by family members and concerned citizens in our communities; and

WHEREAS, Camden County's vulnerable and older adults of all social, economic, racial and ethnic back-grounds may be targets of abuse, neglect or exploitation, which can occur in families, long-term care settings and communities; and

WHEREAS, protecting Camden County's vulnerable and older adults is a community responsibility and all citizens are charged under North Carolina General Statute (GS 108A-102) to report suspected abuse, neglect or exploitation to the Camden County Department Social Services; and

WHEREAS, North Carolina enacted the nation's first elder abuse law in 1973; and

WHEREAS, May 8, 2015 through June 22, 2015 is Vulnerable Adult and Elder Abuse Awareness Month in North Carolina and this time frame ties the awareness period to both the Mothers' Day and Fathers' Day holidays, in the hopes of reinforcing the spirit of respecting and valuing, not just parents, but all elders; and

WHEREAS, we all have a responsibility to support the safety, welfare, and dignity of Camden County's vulnerable and older adults;

NOW, THEREFORE, the Camden County Board of Commissioners, hereby proclaims May 8 - June 22, 2015, as 'ELDER ABUSE AWARENESS MONTH' in the County of Camden, and commend its observance to all citizens, asking them to wear purple Elder Abuse Awareness ribbons, and we further do hereby proclaim June 15, 2015, 'WORLD ELDER ABUSE AWARENESS DAY'; and urge all citizens to work together to help protect elder adults from abuse, neglect, and exploitation because it is imperative that we refuse to tolerate the indignity of Elder Abuse.

Adopted, this the ___ day of April, 2015, in Camden County North Carolina.

P. Michael McLain, Chairman
Board of Commissioners

ATTEST: _____
Angela L. Wooten
Clerk to the Board

(SEAL)

272
273
274
275
276
277
278
279
280
281

Item 7.F - Personnel Policy Revision

The revision removes the language “six months” of, in an effort to make it just read probationary period as there are not only six months but nine and twelve months probationary periods for various departments.

Item 7.G - Ordinance No. 2015-06-01 Supplement 14 Adoption

CAMDEN COUNTY BOARD OF COMMISSIONERS
Regular Meeting – June 15th, 2015

ORDINANCE No. 2015-06-01

AN ORDINANCE ENACTING AND ADOPTING A SUPPLEMENT TO THE CODE OF ORDINANCES FOR CAMDEN COUNTY, AND DECLARING AN EMERGENCY.

WHEREAS, American Legal Publishing Corporation of Cincinnati, Ohio, has completed the 14th supplement to the Code of Ordinances of the Political Subdivision, which supplement contains all ordinances of a general and permanent nature enacted since the prior supplement to the Code of Ordinances of this Political Subdivision; and

WHEREAS, American Legal Publishing Corporation has recommended the revision or addition of certain sections of the Code of Ordinances which are based on or make reference to sections of the NC code; and

WHEREAS, it is the intent of the Legislative Authority to accept these updated sections in accordance with the changes of the law of the State of NC; and

WHEREAS, it is necessary to provide for the usual daily operation of the municipality and for the immediate preservation of the public peace, health, safety and general welfare of the municipality that this ordinance take effect at an early date;

NOW, THEREFORE, BE IT ORDAINED BY THE LEGISLATIVE AUTHORITY OF THE POLITICAL SUBDIVISION OF CAMDEN COUNTY:

Section 1 That the 14th supplement to the Code of Ordinances of the Political Subdivision as submitted by American Legal Publishing Corporation of Cincinnati, Ohio, and as attached hereto, be and the same is hereby adopted by reference as if set out in its entirety.

Section 2 Such supplement shall be deemed published as of the day of its adoption and approval by the Legislative Authority and the Clerk of the Political Subdivision is hereby authorized and ordered to insert such supplement into the copy of the Code of Ordinances kept on file in the Office of the Clerk.

Section 3 This ordinance is declared to be an emergency measure necessary for the immediate preservation of the peace, health, safety and general welfare of the people of this municipality, and shall take effect at the earliest date provided by law.

PASSED AND ADOPTED by the Legislative Authority of the Political Subdivision on this 15th day of June, 2015.

282
283

284 Item 7.H - Set Public Hearing Date for Ordinance No. 2015-06-03 – proposed
285 amendments to Chapter 151 (UDO) Code of Ordinances

286

287 Proposed amendments to additional Specific Standards (Article 151.347) for Solar
288 Farms and amendments to Floodplain Management language (Article 151.380
289 thru 151.387) Set Public Hearing date for Monday July 6th, 2015.

290

291 Item 7.I - Surplus - GovDeals

292

CAMDEN COUNTY BOARD OF COMMISSIONERS
 Regular Meeting – June 15th, 2015

ITEM INFORMATION FOR ASSET ID: 42			
Item: 1998 Ford F-150 XL Reg. Cab Short Bed 2WD			
Pick Up Location: 330 Us Highway 158 E. Camden, NC 27921-7525			
Inventory ID: 0036	Account ID: 1989		
Condition: See Description	Quantity: 1 each		
Make/Brand: Ford	Model: F-150		
VIN/Serial: 1FTZF1761WNC27716	Model Year: 1998		
Meter: 183,950 Miles	Title Restrictions: No		

Date	Item		Amount
06/10/2015 9:09 AM	1998 Ford F-150 XL Reg. Cab Short Bed 2WD		\$1,075.00
	Tax	None	\$0.00
	Administrative Fee		\$80.62
		Total	\$1,155.62

Payment Instructions:
 Payment in full is due not later than 5 business days from the time and date of the Buyer's Certificate and approval by the Board of County Commissioners. Acceptable

293
 294
 295
 296
 297
 298
 299

Item 7.J - Set Public Hearing Camden Towne Center Sewer & Water Line Extension Betterment

Set Public Hearing Date for July 6th, 2015

300
 301
 302
 303
 304
 305
 306
 307

Commissioner's Report

Vice Chairman Duckwall mentioned that as of July 1st the South Mills Fire Station will be staffed with an EMS crew.

Chairman McClain added that the SPCA will be moving into a new building.

308
 309
 310
 311
 312
 313
 314

County Manager's Report

County Manager Mike Renshaw had the following items to report:

One Mill Park is on track and should be completed before the new Fiscal Year.

315
 316
 317
 318
 319

Information from Board and Staff

The following items were provided to the Board for their information, and a copy of these items is maintained in the Clerk's office.

CAMDEN COUNTY BOARD OF COMMISSIONERS
Regular Meeting – June 15th, 2015

- 320
321 A. Sheriff's Monthly Report - May
322 B. Register of Deeds Monthly Report - May
323 C. Taylors Beach Landing Road Addition
324 D. Albemarle Commission - Letter of Support for EDA Grant
325 E. Sales Tax Distribution
326 F. Senate Unveils Revised HB 117 Including Updated Sales Tax Distribution Plan,
327 Questions Remain

328 **Meeting Adjourned**

329
330 At 8:30 PM, Chairman Michael McLain asked if there were any other matters to
331 come before the Board of Commissioners, hearing none, and by acclamation the
332 meeting was adjourned.

333
334
335

Chairman Michael McLain
Camden County Board of Commissioners

336
337
338 ATTEST:

339
340
341

Angela L. Wooten
Clerk to the Board

342
343

1 **Camden County Board of Commissioners**
2 **Budget Hearing**
3 **June 8, 2015, 7:00 P.M.**
4 **Historic Courtroom, Courthouse Complex**
5 **Camden, North Carolina**

6
7 **MINUTES**
8

9 A special meeting of the Camden County Board of Commissioners was held on June 8,
10 2015 in the Upstairs Historic Courtroom, Camden, North Carolina. The following
11 Commissioners were present:

12
13 Chairman Michael McLain, Vice Chairman Sandra Duckwall,
14 Commissioners Garry Meiggs, Tom White and Clayton Riggs;

15
16 Also attending were County Manager Michael Renshaw, and Clerk to the Board Angela
17 L. Wooten.

18
19 **Public Hearing 7:00 P.M.**
20

21 Chairman Michael McLain called to order the June 8, 2015 special meeting of the
22 Camden County Board of Commissioners at 7:00 PM.

23
24 Chairman Michael McLain Clayton Riggs called for a motion to go into public hearing.

25
26 Commissioners Clayton Riggs made a motion to go into public hearing for the purpose of
27 receiving public input regarding the proposed FY2015-16 Camden County Budget. The
28 motion passed 5-0 with Chairman Michael McLain, Vice Chair Sandra Duckwall,
29 Commissioners Garry Meiggs, Clayton Riggs and Tom White voting aye; no
30 Commissioner voting no; no Commissioner absent; and no Commissioner not voting.

31
32 Chairman Michael McLain asked if there were any public comments regarding the
33 proposed FY2015-16 Camden County Budget.

34
35 **Public Comments:**
36

37 A former Camden County Water and Sewer employee Steve Harris of Shipyard Rd came
38 to the board with the following comments;

39
40 Attended Water & Sewer school and feels the county runs their Water & Sewer
41 Department completely opposite of what he learned.

- 42
43 ➤ Example #1 - Water Meters are your cash registers
44 ○ In October 2012 the county's largest water meter was reported broken and not
45 repaired until January 2015.
46 ➤ Example #2 - Water system should be kept in good operating condition

CAMDEN COUNTY BOARD OF COMMISSIONERS
Special Meeting - Budget Hearing – June 8, 2015

- 47 ○ In June 2013 Mr. Harris reported 12 inch water main was leaking at the Noblett
48 Farm on Highway 343
- 49 ➤ Example #3 – Sewer Lift Stations are in poor condition
- 50 ○ Most stations run with a damaged pump or no pump at all
- 51 ○ Raw sewage seeps out
- 52 ○ Camden county Log books are not updated.

53 Terri Faison of 234 South 343 in Camden comes to the board as the manager of River
54 Bridge Apartments in Camden.

- 55
- 56 ➤ The River Bridge apartment complex has 84 units all having 2 bedrooms and one
57 bathroom.
- 58 ➤ Having paid \$40,000/yr. in taxes and \$33,000 for Water & Sewer usage in 2014, the
59 complex is a major asset to Camden.
- 60 ➤ Upset about the proposed increase to taxes, water & Sewer fees and additional
61 personnel
- 62 ➤ She believes that the board has spent money frivolously and is now looking to the tax
63 payers for a bail out.

64 Chairman McLain asked if there were any other comments from the public. Hearing none
65 he asked the County Manager Mike Renshaw to give a brief overview of the proposed
66 FY2015-16 Camden County Budget:

67

68 Manager Renshaw states that a copy of the proposed budget is on file in the clerk's office
69 for public inspection. He then gave brief overview of the proposed FY15-16 Camden
70 County Budget.

71

72 **Snapshot of Proposed FY15-16 Camden County Budget**

- 73
- 74 • General Fund \$11,802.839 - 2.7% increase from the current budget
- 75 • Ad Valorem Property Tax \$0.68/\$100 valuation - 1% reduction
- 76 • 3% increase to schools current expense
- 77 • 2% cost of living increase for county staff
- 78 • 1 Full Time and 1 Part Time employee
- 79 • \$220,000 adding additional EMS coverage at the South Mills VFD Station 14
- 80 • \$89,000 UDO Rewrite

81 **Outstanding Items from the May 19th & May 21st Budget Work Session**

82

83 Courthouse/Shiloh VFD

84

85 Amend the proposed \$469,000.00 county fire truck purchase loan to
86 \$219,000. The fire commission has advised they will use \$250,000.00 of their available
87 fund balance, leaving \$219,000 needed from the county.

88

89 This makes a net effect of \$86,000 in revenue.

90

91 Fund Balance Appropriations

92

93 The County Manager recommends applying the \$86,000 to the required fund
94 balance appropriation, reducing it from \$181,000.00 to \$95,178.00.

95

96 McClees Contract Funding

97

98 The County Manager asks for the board's direction on the McClees Contract as
99 this was not included in the proposed budget. Current \$15,000 agreement with McClees
100 will expire in December 2015.

101

102 After much discussion, it was decided to see reevaluate in December when the agreement
103 expires as the county can do a budget amendment if they agree.

104

105 Schedule of Fees

106

107 Adopt and update the current Schedule to include a Commercial Gravity Sewer
108 Connection Fee of \$3,500.00.

109

110 Update the previously approved \$30.00 Lifetime Dog & Cat License fee and the Solar
111 Panel Fees.

112

113 Public Defender and District Attorney Office Space

114

115 North Carolina requires each county to provide adequate office space for the
116 Public Defender and District Attorney. Camden allots \$11,704 to Pasquotank County for
117 this space, as Camden does not have adequate space for this. The board directs the
118 county manager to look into the cost of providing this space within Camden.

119

120 Chairman Michael McLain asked if there were any questions for Manager Renshaw.
121 Hearing none, he called for a motion to come out of Public Hearing.

122

123 Vice Chair Sandra Duckwall made a motion to come out of public hearing. The motion
124 was approved 5-0 with Chairman Michael McLain, Vice Chair Sandra Duckwall,
125 Commissioners Garry Meiggs, Clayton Riggs and Tom White and voting aye; no
126 Commissioner voting no; no Commissioner absent; and no Commissioner not voting.

127

128

CAMDEN COUNTY BOARD OF COMMISSIONERS
Special Meeting - Budget Hearing – June 8, 2015

129 **Meeting Adjourned**

130

131 By acclamation of Chairman Michael McLain, the meeting was adjourned at 7:36 PM.

132

133

134

135

136

137

138

Chairman Michael McLain
Camden County Board of Commissioners

139

140 ATTEST:

141

142

143

Angela L. Wooten

144 Clerk to the Board

145

DRAFT