



**CAMDENCOUNTY**  
new energy. new vision.

**BOARD  
OF  
COMMISSIONERS**

**September 21<sup>st</sup>, 2015**

**7:00 PM - Regular Meeting**

**Historic Courtroom  
Courthouse Complex**

*This agenda is only a tentative schedule of matters the Commissioners may address at their meeting and all items found on it may be deleted, amended or deferred. The Commissioners may also, in their absolute discretion, consider matters not shown on this agenda.*

**Please turn Cell Phone ringers off during the meeting.**

**Agenda**

**Camden County Board of Commissioners Regular Meeting  
September 21st, 2015  
7:00 P.M. - Regular Meeting  
Historic Courtroom, Courthouse Complex  
Camden, North Carolina**

**7:00 P.M.**      **Call to Order** - Chairman P. Michael McLain

**Welcome**

**Invocation & Pledge of Allegiance** - Chairman P. Michael McLain

**ITEM 1.**      **Public Comments**

It is requested that comments be limited to (2-3) minutes. The length and number of comments may be limited upon the Chairman’s discretion due to scheduling and other issues.

**ITEM 2.**      **Consideration of Agenda** (For discussion and possible action)

**ITEM 3**      **Presentations**

A.      NCACC September Update Video ..... (Pg. 4)

**ITEM 4.**      **Public Hearings**

A.      Amendment to Camden County Code of Ordinances,  
Table of Permissible Uses..... (Pg. 5-6)

**ITEM 5.**      **New Business** (For discussion and possible action)

A.      Monthly Tax Report - August ..... (Pg. 7-14)

B.      Accela Agenda Management Software..... (Pg. 15-22)

**ITEM 6.**      **Consent Agenda** (All items listed below are routine and will be approved by one motion. Separate discussion of an item(s) will be held by request of a member of the Board.)

A.      Draft Minutes – July 6<sup>th</sup>, 2015 ..... (Pg. 23)

B.      Tax Collection Report ..... (Pg. 24-25)

C.      Tax Refunds, Pickups, & Releases ..... (Pg. 26-29)

D.      Tax Authorization to Collect ([#] Renewals)..... (Pg. 30-31)

**ITEM 7. Commissioner's Report (For discussion and possible action)**

**ITEM 8. County Manager's Report (For discussion and possible action)**

**Recess Commissioner's Meeting**

---

**SOUTH CAMDEN WATER & SEWER DISTRICT**  
**BOARD OF DIRECTORS**

1. Call to Order
2. Public Comments
3. Consideration of Agenda
4. Consent Agenda
  - A. Draft Minutes – July 6<sup>th</sup>, 2015 ..... (Pg. 33)
6. New Business (For Discussion and Possible Approval)
  - A. Water System Specifications ..... (Pg. 34-142)
7. Other Matters (For Discussion and possible action.)
8. Adjourn

---

**Reconvene Commissioner’s Meeting**

**ITEM 9. Information, Reports & Minutes From Other Agencies ..... (Pg. 143-178)**

- A. Sales Tax Report..... (Pg. 144-145)
- B. Camden County Economic Development ..... (Pg. 146-153)
- C. Sheriff's Monthly Report - August ..... (Pg. 154)
- D. Albemarle RC&D annual report 14-15.pdf ..... (Pg. 155-158)
- E. Letter from Senator Richard Burr ..... (Pg. 159)
- F. EMS Response Times – July ..... (Pg. 160-161)
- G. EMS Monthly Reports – August & September ..... (Pg. 162-176)
- H. 2015 Eastern 4-H Shooting Sports..... (Pg. 177)
- I. Thank you Letter from College of the Albemarle..... (Pg. 178)

**ITEM 10. Other Matters (For discussion and possible action)**

**ITEM 11. Adjourn**

**Camden County Board of Commissioners  
AGENDA ITEM SUMMARY SHEET**

**Item Number: 3.A**

**PRESENTATION**

**Meeting Date: September 21<sup>st</sup>, 2015**

**Attachments: 1 (1 Page)**

**Submitted By: Clerk to the Board,  
Angela Wooten**

**ITEM TITLE: NCACC September Update Video**

**SUMMARY:**

**RECOMMENDATION:**

<b>MOTION MADE BY:</b>	
S. Duckwall	
G. Meiggs	
M. McLain	
C. Riggs	
T. White	
NO MOTION	
<b>VOTE:</b>	
S. Duckwall	
G. Meiggs	
M. McLain	
C. Riggs	
T. White	
ABSENT	
RECUSED	



**Camden County Board of Commissioners  
AGENDA ITEM SUMMARY SHEET**

**Item Number:** 4.A

**PUBLIC COMMENTS**

**Meeting Date:** September 21<sup>st</sup>, 2015

**Attachments:** 1 (1 Page)

**Submitted By:** Planning Staff

**ITEM TITLE:** Amendment to Camden County  
Code of Ordinances, Table of  
Permissible Uses

**MOTION MADE**

**BY:**

**S. Duckwall** \_\_\_\_\_

**G. Meiggs** \_\_\_\_\_

**M. McLain** \_\_\_\_\_

**R. Krainiak** \_\_\_\_\_

**C. Riggs** \_\_\_\_\_

**NO MOTION** \_\_\_\_\_

**VOTE:**

**S. Duckwall** \_\_\_\_\_

**G. Meiggs** \_\_\_\_\_

**M. McLain** \_\_\_\_\_

**R. Krainiak** \_\_\_\_\_

**C. Riggs** \_\_\_\_\_

**ABSENT** \_\_\_\_\_

**RECUSED** \_\_\_\_\_

**SUMMARY:**

On August 19, 2015, the Camden County Planning Board heard a request from Sheriff Tony Perry for an amendment to the Camden County Code of Ordinances, Table of Permissible Uses, to allow shooting ranges for Law Enforcement use only in the following zoning districts: GUD, I-1, I-2.

Such range would be subject to County Ordinance §151.347(S) which sets buffers, setbacks, and incorporates the military handbook for range facilities and miscellaneous training facilities by reference.

On a 6-0 vote, with one member absent, the Planning Board voted to recommend approval of this amendment.

**RECOMMENDATION:**

Approve amendment.

BOARD OF COMMISSIONERS

P. MICHAEL McLAIN  
Chairman

SANDRA J. DUCKWALL  
Vice Chairman

GARRY W. MEIGGS  
CLAYTON D. RIGGS  
TOM WHITE



**CAMDENCOUNTY**  
new energy. new vision.

MICHAEL RENSHAW  
County Manager

ANGELA WOOTEN  
Clerk to the Board

JOHN S. MORRISON  
County Attorney

**Ordinance No. 2015-08-01**

**An Ordinance Amending the Camden County Code of Ordinances Camden County, North Carolina**

BE IT ORDAINED BY THE CAMDEN COUNTY BOARD OF COMMISSIONERS as follows:

**Article I: Purpose**

The purpose of this Ordinance is to amend Chapter 151 of the Camden County Code of Ordinances of Camden County, North Carolina, which was originally adopted by the County Commissioners on December 15, 1997, and subsequently amended and as otherwise incorporated into the Camden County Code.

**Article II. Construction**

For purposes of this Ordinance, underlined words (underline) shall be considered as additions to existing Ordinance language and strikethrough words (~~strikethrough~~) shall be considered deletions to existing language. New language of proposed ordinance shall be shown in italics (*italics*) and underlined.

**Article III. Amend Chapter 151 as amended of the Camden County Code which shall read as follows:**

**CHAPTER 151: UNIFIED DEVELOPMENT**

**§ 151.334 TABLE OF PERMISSIBLE USES.**

USE#	DESCRIPTION	R-1	R-2	R-3	CCD	NCD	HC	MC	GUD	I-1	I-2
6.310	<i><u>Private Outdoor Firing Range - Law Enforcement Only Subject to §151.347(S)</u></i>								<u>S</u>	<u>S</u>	<u>S</u>

Adopted by the Board of Commissioners for the County of Camden this 21<sup>st</sup>, day of September, 2015.

ATTEST

(SEAL)

\_\_\_\_\_  
Chairman P. Michael McLain

\_\_\_\_\_  
Angela Wooten, Clerk

**Camden County Board of Commissioners  
AGENDA ITEM SUMMARY SHEET**

**Item Number:** 5.A

**New Business**

**Meeting Date:** September 21, 2015  
**Attachments:** 7  
**Submitted By:** Lisa S. Anderson  
Tax Administrator

**ITEM TITLE:** August Monthly Reports

**SUMMARY:**

August Monthly Reports

**RECOMMENDATION:**

Review & Approve

<b>MOTION MADE BY:</b>	
S. Duckwall	
G. Meiggs	
M. McLain	
C. Riggs	
T. White	
NO MOTION	
<b>VOTE:</b>	
S. Duckwall	
G. Meiggs	
M. McLain	
C. Riggs	
T. White	
ABSENT	
RECUSED	

**MONTHLY REPORT OF THE TAX ADMINISTRATOR TO THE  
CAMDEN COUNTY BOARD OF COMMISSIONERS**

**OUTSTANDING TAX DELINQUENCIES BY YEAR**

<b><u>YEAR</u></b>	<b><u>REAL PROPERTY</u></b>	<b><u>PERSONAL PROPERTY</u></b>
2014	175,460.76	8,701.21
2013	68,362.42	10,420.52
2012	29,854.90	12,907.83
2011	17,105.86	10,424.16
2010	17,196.35	6,447.94
2009	7,064.74	6,061.83
2008	6,133.35	6,252.36
2007	6,056.33	9,606.28
2006	1,996.46	14,453.25
2005	1,690.71	26,367.95

TOTAL REAL PROPERTY TAX UNCOLLECTED	330,921.88
TOTAL PERSONAL PROPERTY UNCOLLECTED	111,643.33
TEN YEAR PERCENTAGE COLLECTION RATE	99.34%
COLLECTION FOR 2015 vs. 2014	20,554.15 vs. 18,367.51

**LAST 3 YEARS PERCENTAGE COLLECTION RATE**

2014	97.29%
2013	98.88%
2012	99.40%

**THIRTY LARGEST UNPAID ACCOUNTS**

**SEE ATTACHMENT "A"**

**THIRTY OLDEST UNPAID ACCOUNTS**

**SEE ATTACHMENT "B"**

**EFFORTS AT COLLECTION IN THE LAST 30 DAYS**

**ENDING August 2015**  
**BY TAX ADMINISTRATOR**

- 381 NUMBER DELINQUENCY NOTICES SENT
- 27 FOLLOWUP REQUESTS FOR PAYMENT SENT
- 4 NUMBER OF WAGE GARNISHMENTS ISSUED
- 12 NUMBER OF BANK GARNISHMENTS ISSUED
- 14 NUMBER OF PERSONAL PHONE CALLS MADE BY TAX ADMINISTRATOR TO DELINQUENT TAXPAYER
- 0 NUMBER OF PERSONAL VISITS CONDUCTED (COUNTY OFFICES)
- 0 PAYMENT AGREEMENTS PREPARED UNDER AUTHORITY OF TAX ADMINISTRATOR
- 2 NUMBER OF PAYMENT AGREEMENTS RECOMMENDED TO COUNTY ATTORNEY
- 0 NUMBER OF CASES TURNED OVER TO COUNTY ATTORNEY FOR COLLECTION (I.D. AND STATUS)
- 0 REQUEST FOR EXECUTION FILES WITH CLERK OF COURTS
- 0 NUMBER OF JUDGMENTS FILED

Roll	Parcel Number	Unpaid Amount	YrsDlq	Taxpayer Name	City	Property Address
R	03-8971-00-12-0477.0000	18,187.53	1	GILBERT WAYNE OVERTON &	SHILOH	187 THOMAS POINT RD
R	01-7989-00-01-1714.0000	9,660.86	1	CHARLES MILLER HEIRS	SOUTH MILLS	HORSESHOE RD
R	02-8923-00-19-3774.0000	9,070.52	1	HALSTEAD VENTURE PARTNERS, LLC	CAMDEN	431 158 US W
R	01-7080-00-17-0129.0000	8,221.36	1	CAMDEN SQUARE ASSOCIATES	SOUTH MILLS	
R	03-8899-00-45-2682.0000	7,095.06	1	SEAMARK INC.	SHILOH	HOLLY RD
R	01-7998-01-08-8621.0000	6,199.91	2	WILLIE L. TURNER ETAL	SOUTH MILLS	1289 343 HWY N
R	03-8972-00-51-8423.0000	5,904.26	1	BRITTON OVERTON	SHILOH	103 WESLEY RD
R	02-8944-00-31-2148.0000	5,569.25	1	CARL HARRINGTON	CAMDEN	150 SAND HILLS RD
R	02-8945-00-54-1099.0000	5,482.12	1	GERTIE LEE & JONOLA T ROUNTREE	CAMDEN	263 BELCROSS RD
R	03-8943-04-74-3506.0000	5,428.11	1	ELLIOTT & DONNA JACOBS	SHILOH	117 SUNSET AVE
R	03-8953-04-81-9832.0000	5,259.29	3	MAIDIA S. CECIL HEIRS	SHILOH	113 TROTMAN RD
R	01-8000-00-36-9596.0000	4,784.75	1	EULA B. JOYNER	SOUTH MILLS	TROTTERS WAY
R	02-8945-00-41-2060.0000	4,206.54	1	LASELLE ETHERIDGE SR.	CAMDEN	168 BUSHELL RD
R	03-8990-00-08-7291.0000	4,066.47	1	JAMES E RHODES	SHILOH	111 CATALAN DR
R	03-8952-01-49-1090.0000	3,621.40	1	DRACHMA, INC & SIMSON BAAI, LLC	SHILOH	343 HWY S
R	01-7080-00-62-1977.0000	3,495.60	8	SANDERS CROSSING OF CAMDEN CO	SOUTH MILLS	117 OTTERS PL
R	03-8961-00-58-4506.0000	3,371.91	1	WARREN DEAN RIGGS	SHILOH	110 DRIFTWOOD DR
R	01-7998-01-08-6797.0000	3,131.98	4	EDWARD E. HARRIS JR.	SOUTH MILLS	1295 343 HWY N
R	03-8965-00-44-7928.0000	3,102.74	1	WHALON & KATHLEEN MCCULLEN	SHILOH	404 SANDY HOOK RD
R	03-8971-00-23-2253.0000	3,016.38	1	ABODE OF CAMDEN, INC.	SHILOH	187 C THOMAS POINT RD
R	01-7989-04-60-3728.0000	2,942.77	1	JAMES R. & SHIRLEY GRIFFIN	SOUTH MILLS	208 CANAL DR
R	03-8962-00-56-7217.0000	2,914.53	1	TONYA HUGHES HARRIS	SHILOH	253 WICKHAM RD
R	02-8936-00-21-4428.0000	2,908.81	2	CAROLYN MCDANIEL	CAMDEN	SCOTLAND RD
R	01-7989-04-90-6715.0000	2,900.35	4	ANDREW FEREBEE HEIRS	SOUTH MILLS	1334 343 HWY N
R	03-8964-00-40-9957.0000	2,869.66	1	LASALLE SEARS HEIRS	SHILOH	291 BARTLETT RD
R	02-8934-04-61-9891.0000	2,864.33	1	WILLIAM EDGAR STAPLES	CAMDEN	244 COUNTRY CLUB RD
R	02-8934-01-07-9286.0000	2,705.59	1	CAMDEN SALES & SERVICE	CAMDEN	166 158 US W
R	02-8934-04-71-8470.0000	2,700.25	1	JAMES MILTON JONES ETAL	CAMDEN	267 COUNTRY CLUB RD
R	02-8943-01-26-9508.0000	2,570.16	1	FITZHERBERT, ADELL & BARBARA	CAMDEN	108 RIDGE RD
R	02-8935-01-08-8786.0000	2,558.35	1	LINWOOD GREGORY	CAMDEN	253 SLEEPY HOLLOW RD

09/02/15 08:05:43

Delinquencies Top-30 Unpaid

1

Attachment "A"  
 Real

Roll	Parcel Number	YrsDlq	Unpaid Amount	Taxpayer Name	City	Property Address
R	03-8899-00-45-2682.0000	10	7,095.06	SEAMARK INC.	SHILOH	HOLLY RD
R	01-7998-01-08-8621.0000	10	6,199.91	WILLIE L. TURNER ETAL	SOUTH MILLS	1289 343 NC N
R	03-8943-04-93-8214.0000	10	2,287.69	L. P. JORDAN HEIRS	SHILOH	108 CAMDEN AVE
R	01-7999-00-32-3510.0000	10	1,928.53	LEAH BARCO	SOUTH MILLS	195 BUNKER HILL RD
R	03-8952-00-95-8737.0000	10	1,908.86	AUDREY TILLET	SHILOH	171 NECK RD
R	01-7090-00-60-5052.0000	10	962.62	JOE GRIFFIN HEIRS	SOUTH MILLS	117 GRIFFIN RD
R	02-8955-00-13-7846.0000	10	659.94	MARIE MERCER	CAMDEN	IVY NECK RD
R	02-8936-00-24-7426.0000	10	633.65	BERNICE PUGH	CAMDEN	113 BOURBON ST
R	03-9809-00-45-1097.0000	10	260.40	MICHAEL OBER	SHILOH	CENTERPOINT RD
R	01-7090-00-95-5262.0000	10	255.08	JOHN F. SAWYER HEIRS	SOUTH MILL	OLD SWAMP RD
R	03-8980-00-61-1968.0000	10	218.26	WILLIAMSBURG VACATION	SHILOH	CAMDEN POINT RD
R	03-9809-00-17-2462.0000	10	141.61	TODD ALLEN RIGGS	SHILOH	LITTLE CREEK RD
R	01-7999-00-12-8596.0000	9	1,623.08	MOSES MITCHELL HEIRS	SOUTH MILLS	165 BUNKER HILL RD
R	01-7989-04-60-1954.0000	9	1,129.11	CHRISTINE RIDDICK	SOUTH MILLS	105 BLOODFIELD RD
R	03-8899-00-37-0046.0000	9	162.23	ELIZABETH LONG	SHILOH	HIBISCUS
R	01-7989-00-01-1714.0000	8	9,660.86	CHARLES MILLER HEIRS	SOUTH MILLS	HORSESHOE RD
R	02-8945-00-41-2060.0000	8	4,206.54	LASELLE ETHERIDGE SR.	CAMDEN	168 BUSHELL RD
R	01-7080-00-62-1977.0000	8	3,495.60	SANDERS CROSSING OF CAMDEN CO	SOUTH MILLS	117 OTTERS PL
R	02-8934-04-71-8470.0000	8	2,700.25	JAMES MILTON JONES ETAL	CAMDEN	267 COUNTRY CLUB RD
R	01-7988-00-91-0179.0001	8	1,918.10	THOMAS L. BROTHERS HEIRS	SOUTH MILLS	
R	02-8935-01-19-4055.0000	8	1,219.71	ANDERSON CARTWRIGHT SR.	CAMDEN	271 SLEEPY HOLLOW RD
R	01-7988-00-14-1370.0000	8	847.10	ISAAC COSTON	SOUTH MILLS	NORTH SIDE RD
R	02-8935-03-40-3652.1000	8	782.56	HOWARD DAVENPORT	CAMDEN	117 GUMBERRY RD
R	03-8962-00-50-0273.0000	8	764.31	DAISEY WILLIAMS BURNHAM	SHILOH	RAYMONS CREEK RD
R	01-7998-00-57-2800.1000	8	427.45	TINA RENEE LEARY	SOUTH MILLS	111 LINTON RD
R	01-7989-04-60-1568.0000	7	965.01	EMMA BRITE HEIRS	SOUTH MILLS	116 BLOODFIELD RD
R	03-8971-00-12-0477.0000	6	18,187.53	GILBERT WAYNE OVERTON &	SHILOH	187 THOMAS POINT RD
R	03-8953-04-81-9832.0000	6	5,259.29	MAIDIA S. CECIL HEIRS	SHILOH	113 TROTMAN RD
R	03-8990-00-08-7291.0000	6	4,066.47	JAMES E RHODES	SHILOH	111 CATALAN DR
R	03-8962-00-56-7217.0000	6	2,914.53	TONYA HUGHES HARRIS	SHILOH	253 WICKHAM RD

09/02/15 08:05:44

Delinquencies Top-30 Oldest

1

Attachment "B"  
Roll



Roll	Parcel Number	Unpaid Amount	YrsDlq	Taxpayer Name	City	Property Address
P	0001709	1,531.32	6	JOHN MATTHEW CARTER	CAMDEN	158 HWY
P	0002482	1,349.80	1	MASTEC NORTH AMERICA	CAMDEN	
P	0001046	1,110.60	10	THIEN VAN NGUYEN	SHILOH	133 EDGEWATER DR
P	0000738	1,092.13	4	LESLIE ETHERIDGE JR	CAMDEN	431 158 US W
P	0001538	798.61	7	JEFFREY EDWIN DAVIS	HERTFORD	MIC MAC TRAIL
P	0002342	789.69	1	ASSOCIATED TAX APPRAISERS		
P	0001072	778.93	10	PAM BUNDY	SHILOH	105 AARON DR
P	0001883	655.29	4	DUNG LE TRAN	SHILOH	255 SAILBOAT ROAD
P	0001739	655.07	4	COAST TO COAST POWDER COATING	CAMDEN	330 158 HWY E
P	0001827	652.02	1	KAREN BUNDY	CAMDEN	431 158 US W
P	0001695	547.68	3	GARY STEWART ELKINS	CAMDEN	150 158 HWY W
P	0000352	443.65	9	ROBERT F. NERNEY	ELIZABETH CITY	107 SMALL DRIVE
P	0001230	411.11	3	JAMES NYE	SOUTH MILLS	101 ROBIN CT W
P	0001116	409.86	4	AL JORDAN	CAMDEN	390 158 HWY W
P	0000846	405.20	3	TOAN TRINH	SHILOH	229 SAILBOAT RD
P	0001905	340.08	4	AAR CORPORATION ETAL	SOUTH MILLS	211 FLYING TIGER RD
P	0000248	326.53	10	ROBERT H. OWENS	CAMDEN	363 # 15
P	0001227	322.05	9	THUAN NGOC TRAN	SHILOH	257 SAILBOAT RD
P	0000956	314.49	10	HUNG PHI LE	SHILOH	103 EDGEWATER DR
P	0000010	278.61	8	SPRINT NEXTEL CORPORATION	OVERLAND PARK	
P	0000256	270.00	8	JAMES E. NASH	SOUTH MILLS	1097 343 HWY N
P	0001703	270.00	1	VAN ZANDER	MOYOCK	812 TULLS CREEK RD
P	0001672	268.26	5	DAVE SILVA	CAMDEN	390 158 HWY
P	0000295	265.98	2	HENDERSON AUDIOMETRICS, INC.	CAMDEN	330 158 HWY E
P	0001693	261.90	6	ALLIANCE NISSAN	CAMDEN	158 HWY W
P	0002194	251.03	1	MORGAN ROBERSON	SHILOH	849 SANDY HOOK RD S
P	0001250	247.91	5	MICHELE LEE TAYLOR	SOUTH MILLS	108 BINGHAM RD
P	0001010	243.13	2	RAYBURN BURGESS	SHILOH	116 EDGEWATER DR
P	0001106	239.24	8	JAMI ELIZABETH VANHORN	SOUTH MILLS	617 MAIN ST
P	0001952	238.91	3	SANDY BOTTOM MATERIALS, INC	SOUTH MILLS	319 PONDEROSA RD

09/02/15 08:06:07

Delinquencies Top-30 Unpaid

1

*Attachment "A"  
Personal*

Roll	Parcel Number	YrsDlq	Unpaid Amount	Taxpayer Name	City	Property Address
P	0001046	10	1,110.60	THIEN VAN NGUYEN	SHILOH	133 EDGEWATER DR
P	0000738	10	1,092.13	LESLIE ETHERIDGE JR	CAMDEN	
P	0001072	10	778.93	PAM BUNDY	SHILOH	105 AARON DR
P	0000248	10	326.53	ROBERT H. OWENS	CAMDEN	363 # 15
P	0000956	10	314.49	HUNG PHI LE	SHILOH	103 EDGEWATER DR
P	0001220	10	219.05	KIMBERLY DIANE JOHNSON	SOUTH MILLS	172 KEETER BARN RD
P	0000837	10	139.42	DUC MINH LE		
P	0000316	10	122.12	JAMES P. JONES	CAMDEN	142 SANDHILLS RD
P	0000352	9	443.65	ROBERT F. NERNEY	ELIZABETH CITY	107 SMALL DRIVE
P	0001227	9	322.05	THUAN NGOC TRAN	SHILOH	257 SAILBOAT RD
P	0001106	9	239.24	JAMI ELIZABETH VANHORN	SOUTH MILLS	617 MAIN ST
P	0000010	8	278.61	SPRINT NEXTEL CORPORATION	OVERLAND PARK	
P	0000256	8	270.00	JAMES E. NASH	SOUTH MILLS	1097 343 HWY N
P	0001538	7	798.61	JEFFREY EDWIN DAVIS	HERTFORD	MIC MAC TRAIL
P	0001545	7	160.66	LOUIS RUGGERI	ELIZABETH CITY	CAMDEN CAUSEWAY
P	0001540	7	120.95	DAVID LUKE	ELIZABETH CITY	CAMDEN CAUSEWAY
P	0001709	6	1,531.32	JOHN MATTHEW CARTER	CAMDEN	158 HWY
P	0001672	6	268.26	DAVE SILVA	CAMDEN	158 HWY
P	0001693	6	261.90	ALLIANCE NISSAN	CAMDEN	158 HWY W
P	0001673	6	177.05	THOMAS PHILLIP WINSLOW	CAMDEN	158 HWY W
P	0001827	5	652.02	KAREN BUNDY	CAMDEN	431 158 US W
P	0001250	5	247.91	MICHELE LEE TAYLOR	SOUTH MILLS	108 BINGHAM RD
P	0002775	5	235.33	JEFFREY D & KIMBERLEE S KENNEY	SOUTH MILLS	164 MCPHERSON RD
P	0001910	5	155.91	JEFFREY GEGAN	CAMDEN	379 COUNTRY CLUB RD
P	0001883	4	655.29	DUNG LE TRAN	SHILOH	255 SAILBOAT ROAD
P	0001739	4	655.07	COAST TO COAST POWDER COATING	CAMDEN	330 158 HWY E
P	0001116	4	409.86	AL JORDAN	CAMDEN	390 158 HWY W
P	0001905	4	340.08	AAR CORPORATION ETAL	SOUTH MILLS	211 FLYING TIGER RD
P	0000421	4	227.73	CLARENCE MUNDEN	CAMDEN	
P	0002081	4	217.24	ROBERT VERNON BRAY	CAMDEN	120 LAUREN LANE

09/02/15 08:06:08

Delinquencies Top-30 Oldest

Attachment "B"  
 1 Personal

**Camden County Board of Commissioners  
AGENDA ITEM SUMMARY SHEET**

**Item Number:** 5.B

**New Business**

**Meeting Date:** September 21, 2015  
**Attachments:** 3 (6 Pages)  
**Submitted By:** Michael Renshaw, County Manager

**ITEM TITLE:** Accela Legislative Management Government Meeting Management Software Proposal

<b>MOTION MADE BY:</b>	
S. Duckwall	
G. Meiggs	
M. McLain	
C. Riggs	
T. White	
NO MOTION	
<b>VOTE:</b>	
S. Duckwall	
G. Meiggs	
M. McLain	
C. Riggs	
T. White	
ABSENT	
RECUSED	

**SUMMARY:**

In 2012 the Board of Commissioners approved the implementation of a paperless Board meeting packet process utilizing mobile iPad devices as a means of saving time and costs associated with compiling meeting documents. During this initial phase of implementation, staff also discussed a variety of software packages which would provide a more streamlined process in creating Board packets and then posting the information for Board member use. The decision was made at the time to simply utilize existing software and deployment methods (namely Adobe Acrobat and DropBox) to create and manage the distribution of Board packets.

The Clerk to the Board and County Manager recently attended a Webinar conference call with representatives of Accela, a company with a long and successful reputation as a provider of government software solutions focused on enhancing productivity and efficiency in the management of agendas, supporting documentation, and meeting minutes. The attached materials describe one such software package, Government Meeting Management Software.

**Government Meeting Management Software offers streamlined “one click” agenda and Board packet building using Microsoft Office integration and fully customizable document templates. Importantly, the software utilizes an agenda item tracking, routing, and approval system which will assist the Clerk to the Board in ensuring that agenda items have been submitted, reviewed and approved in a timely manner. The other very significant feature of this software package is the provision of a Minute Maker which allows the Clerk to produce meeting minutes faster. This feature also allows the minutes to be completely word-searchable by Commissioners, residents, and staff. As part of this proposal, Accela has also committed to transferring the County’s past Board minutes to the system, making these minutes fully searchable as well.**

**Included in this proposal is a listing of some of the existing North Carolina county government Accela clients, which include Currituck County, Burke County, Alamance County, and Montgomery County. The Clerk to the Board has spoken with her counterparts in these counties and received very favorable reviews and recommendations.**

**The Accela proposal of \$540 per month includes all costs including training and full implementation. Accela is also offering this package at no risk, meaning the County may opt to terminate at any time with 30 day prior written notice**

**RECOMMENDATION:**

**The County Manager, in consultation with the Clerk to the Board, recommends that the Board of Commissioners approve the attached contract agreement with Accela Legislative Management for the provision of the Government Meeting Management Software package as presented at a cost of \$540 per month and authorize the County Manager to execute said contract agreement.**



**Accela**  
Legislative Management

## **Government Meeting Management Software**

### **CAMDEN COUNTY, NC**

Submitted By:

**Shaun Morse**  
Business Development Executive  
[smorse@accela.com](mailto:smorse@accela.com)  
(508) 397-6309

Accela  
100 Comac Street  
Ronkonkoma, NY 11779  
(631) 389-3691

9/17/2015

## Accela – Legislative Management - Terms, Conditions and Pricing for CAMDEN COUNTY, NC

---

**1. IMPORTANT NOTICE TO USER:** Accela, Inc. ("Accela") owns all intellectual property in the software products Agendas & Minutes, Civic Streaming, Digital Boardroom, Boards & Commissions and Civic Voice (collectively "Software"). Customer shall not modify, adapt, translate, rent, lease or otherwise attempt to discover the Software source code. This Agreement will be governed by the laws in force in the State of California.

**2. Software License.** The Software subscription services and the accompanying files, software updates, lists and documentation are licensed, not sold, to you. You may install and Use a copy of the Software on your compatible computer for the purpose of connecting to the hosted service provided by Accela as long as you are a current subscriber and maintain your monthly or annual continued services for the applicable licenses. Except as expressly set forth herein, Accela disclaims any and all express and implied warranties, including but not limited to warranties of merchantability and fitness for a particular purpose.

### **3. Continued Services**

**3.1 Updates and Renewals.** If the Software is an Update to a previous version of the Software, you must possess a valid license to the previous version in order to use the Update. Corrections of substantial defects in the Software so that the Software will operate as purported will be rectified by Accela. Customer agrees to install all updates, including any enhancements, for the Software in accordance with the instructions provided by Accela.

**3.2 Hosting.** Accela agrees to maintain Customer data in a Tier-2 datacenter and is committed to providing 99.9% uptime and availability. Accela will perform nightly backups of your hosted data to an alternate physical location.

**3.3 Ownership of Data.** All hosted data belongs to the Customer. At the request of the customer Accela will provide a backup of all database information and files through a downloadable backup or DVD. Accela agrees to provide this service without charge at least once per year.

### **4. Payment Terms & Fees**

**4.1 Term and Termination.** Subscription terms are twelve (12) calendar months in duration. The initial Term of this Agreement is effective as of the date of the Customer's signature ("Effective Date") and will continue for 12 months. At the end of the initial 12 month term, Customer's subscription will renew for an additional term unless terminated as provided herein. Accela reserves the right to increase the annual fees by 5% on the anniversary date of each annual renewal term. This agreement can be terminated at any time with 30 days prior written notice.

**4.2 Payment Terms.** **Subscription Services of \$540 month billing will commence on 10/01/2015.** Each subsequent payment will occur on the 1<sup>st</sup> of each month. Payment Terms are **NET 30** Days from the invoice date.

**4.3 On-Site Support and Expenses.** Should on-site support requiring travel by Accela staff be requested by Customer, Accela will provide on-site assistance at Accela's then-current time-and-materials rates. In addition to these charges, Customer will compensate Accela for associated airfare, lodging, rental transportation, meals, and other incidental expenses as such expenses accrue and will be billed at cost and invoiced separately.

**4.4 Hardware.** Hardware, if any, is provided at no additional cost. Accela does not warrant any hardware. Should Accela furnish encoder hardware as part of the Civic Streaming (fka MediaTraQ) video streaming service, hardware warranty is through manufacturer repair or replacement only. Any hardware issues requiring new equipment not covered by the warranty will be billed to the client at cost. Any upgrades, additional encoders, etc. will be billed to client. Any hardware furnished to client as part of Accela's services is to be returned to Accela upon termination of associated services.

**5. Limitation of Liability.** Accela will, at all times during the Agreement, maintain appropriate insurance coverage. To the extent not offset by its insurance coverage and to the maximum extent permitted by applicable laws, in no event will Accela's cumulative liability for any general, incidental, special, compensatory, or punitive damages whatsoever suffered by Customer or any other person or entity exceed the fees paid to Accela by Customer during the twelve (12) calendar months immediately preceding the circumstances which give rise to such claim(s) of liability, even if Accela or its agents have been advised of the possibility of such damages.

**6. Optional Electronic Payment:** Services can be electronically paid through credit card. By submitting your credit card information here you agree to allow Accela to charge your monthly SaaS fee in accordance with our regular payment terms.

Type	Card #	Name on Card	Expires
Billing Address (Street, City, State, Zip)			Security Code

**7. Pricing Structure:**

Description	Monthly SaaS	One Time
Agendas & Minutes - Unlimited	\$540 / mo	
System Configuration, Implementation & Training		Waived/Included
<b>Total – Monthly SaaS</b>	<b>\$540/ mo</b>	

**CAMDEN COUNTY, NC**

**Accela, Inc.**

\_\_\_\_\_  
Signature

\_\_\_\_\_  
Signature

\_\_\_\_\_  
Printed Name, Title

Daryl Blowes, GM / SVP  
Printed Name, Title

\_\_\_\_\_  
Date:

Date: 9/17/2015

\_\_\_\_\_  
Billing Contact:

\_\_\_\_\_  
Billing Address:

## Angela Wooten

---

**Subject:** Accela Proposal

Hi Angela!

It was a pleasure to speak with you today, I appreciate you taking the time out of your day to view a demonstration.

As discussed, I have attached the official pricing proposal. We want to make this as easy of a decision as possible for your organization. There will be no upfront costs. This is also a month to month agreement that allows you to stop at any time. Configuration, training and implementation are included. This no risk model allows us to work with you to prove the savings and citizen approval returns your organization will realize.

If our experience holds true; you and your other stakeholders will be delighted with this model; not to mention the customized, fully searchable citizen and staff web portal we furnish to you as part of the program. The functionality we offer for both now & for future scalability is not resident with any other solution in a single application built from the ground up. We make it very easy.

Please see below for some top level pricing components....

- No Risk - You can stop at any time
- Training & Implementation included
- No Up Front Costs
- No Additional Costs
- Fully Hosted
- Minutes Maker
- Unlimited Users
- Unlimited Meeting groups
- Unlimited Storage
- Unlimited Documents or Archives
- Customizable Self Service Web portal
- 24/7 Support via telephone
- Unlimited Free Access to the Accela Training Academy
- Free Software Updates and Much More.

**\*You may want to reach out to the following references that are using our solutions. I encourage you to ask them about their experiences with the software, as well as the service and support that our company provides\***

Burke County, NC – Kay Draughn – Clerk to the Board - [kay.draughn@burkenc.org](mailto:kay.draughn@burkenc.org) – (828) 439-4341

Alamance County, NC – Tory Frink – Clerk to the Board – [tory.frink@alamance-nc.com](mailto:tory.frink@alamance-nc.com) – (336) 570-4042

Currituck County, NC – Debra Embrey – IT Manager – [debra.embrey@currituckcountync.gov](mailto:debra.embrey@currituckcountync.gov) – (252) 232-6050

Montgomery County, NC – Doshia Haywood – Clerk to the Board – [doshia.haywood@montgomerycountync.com](mailto:doshia.haywood@montgomerycountync.com) – (910) 576-4221 x325

**\*Below are the fully searchable citizen/staff web portals that we provide for the references above.....\***

<http://burkecountync.iqm2.com/Citizens/Default.aspx>



<http://alamancecountync.iqm2.com/Citizens/Default.aspx>

<http://currituckcountync.iqm2.com/Citizens/Default.aspx>

<http://montgomerycountync.iqm2.com/Citizens/Default.aspx>

I look forward to getting your feedback! Most importantly, have a wonderful day!

Best Regards,

**Shaun Morse**

Business Development Executive

Mobile: 508.397.6309 |



---

Better government through civic engagement

# Agenda and Minutes

## Manage your public meeting process - in minutes, not hours

Remove the time, cost and hair-pulling frustration associated with the workflow of public meetings. Simplify your legislative meetings with an easy way to prepare agendas and minutes. Accela automates the entire meeting process for better workflow and productivity.

Agenda and Minutes gives you:

- **One-click agenda building** and distribution with automatic routing of agenda items
- **Configurable document templates** and field descriptors to match agency style and lingo
- **Microsoft Office integration** with ability to format agenda items and easily import files
- **Web and mobile approvals** of agenda items on-the-go
- **Ability to compile, store and track minutes** and agenda items including unlimited data storage

### SIMPLIFY MEETING MANAGEMENT

Gain the ability to track legislation with easy management and preparation of public meetings. Enable improved information flow and record retention online to stop chasing paper.

### SAVE TIME AND REDUCE COSTS

Save time for staff, council members and the public by improving efficiency and eliminating manual, paper-driven civic meeting processes.

### KEEP STAFF AND CITIZENS INFORMED

Build public trust with access to fully searchable meeting content, including legislative decisions and public meeting videos. Keep users engaged and informed by offering content online.



### PROMOTE ACCOUNTABILITY

Follow-up to ensure action items are completed enhancing visibility and improving staff accountability to move the legislative meeting process forward.

#### LEGISLATIVE MANAGEMENT

[AGENDA AND MINUTES](#)
[CIVIC STREAMING](#)
[DIGITAL BOARDROOM](#)
[BOARDS AND COMMISSIONS](#)
[CIVIC VOICE](#)

#### PRODUCT RESOURCES

 [Agenda and Minutes Overview](#)
 [WeGovern App](#)
 [Recorded Webinar: Get More Done - Even on Agenda Packet Days](#)
[REQUEST A DEMO](#)

#### CASE STUDY



"The great thing about this product and why we chose it is that the video of each meeting is integrated with the meeting documents and it also has time-stamp features, making it easy for staff and citizens to quickly find what they are interested in. I love that transparency. It just makes it so much easier."

**Jaime Schroeder, MBA**  
Senior Management Analyst, Office of the City Manager

[Read full case study >](#)

#### PLATFORM

How to Buy  
Architecture

#### SOLUTIONS

Asset Management  
Citizen Relationship Management  
Environmental Health  
Finance & Administration  
Land Management  
Legislative Management  
Licensing & Case Management  
Recreation & Resource Management  
Right of Way Management

#### RESOURCES

Webinars  
Brochures  
Success Stories  
Product Demos  
Videos  
White Papers & eBooks

#### COMPANY

News  
Blog  
Customers  
Events  
Leadership  
Careers  
Partners

#### APPS

SUPPORT

CONTACT US

**Camden County Board of Commissioners  
AGENDA ITEM SUMMARY SHEET**

**Item Number: 6.A**

**CONSENT AGENDA**

**Meeting Date: September 21<sup>st</sup>, 2015**  
**Attachments: 1 (Attachment A)**  
**Submitted By: Clerk to the Board**

**ITEM TITLE: Draft Meeting Minutes**

<b>MOTION MADE BY:</b>	
S. Duckwall	
G. Meiggs	
M. McLain	
C. Riggs	
T. White	
NO MOTION	
<b>VOTE:</b>	
S. Duckwall	
G. Meiggs	
M. McLain	
C. Riggs	
T. White	
ABSENT	
RECUSED	

**SUMMARY:**

July 6<sup>th</sup>, 2015 - E&R Board Draft Minutes  
 July 6<sup>th</sup>, 2015 - BOC Draft Minutes  
 July 6<sup>th</sup>, 2015 - SCWSD Draft Minutes

**RECOMMENDATION:**

**For Review and Possible Approval**

**Camden County Board of Commissioners  
AGENDA ITEM SUMMARY SHEET**

**Item Number: 6.B**

**Consent Agenda**

**Meeting Date: September 21<sup>st</sup>, 2015,**

**2015 Attachments: 1**

**Submitted By: Tax Office**

**ITEM TITLE: Tax Collection Report**

<b>MOTION MADE BY:</b>	
S. Duckwall	
G. Meiggs	
M. McLain	
C. Riggs	
T. White	
NO MOTION	
<b>VOTE:</b>	
S. Duckwall	
G. Meiggs	
M. McLain	
C. Riggs	
T. White	
ABSENT	
RECUSED	

**SUMMARY:**

**Tax Collection Report**

**RECOMMENDATION:**

**Review & Approve**



**Camden County Board of Commissioners  
AGENDA ITEM SUMMARY SHEET**

**Item Number: 6.C**

**Consent Agenda**

**Meeting Date: September 21st, 2015**

**Attachments: 3**

**Submitted By: Tax Office**

**ITEM TITLE: Tax Refunds, Pickups & Releases**

<b>MOTION MADE BY:</b>	
S. Duckwall	
G. Meiggs	
M. McLain	
C. Riggs	
T. White	
NO MOTION	
<b>VOTE:</b>	
S. Duckwall	
G. Meiggs	
M. McLain	
C. Riggs	
T. White	
ABSENT	
RECUSED	

**SUMMARY:**

**Tax Refunds, Pickups & Releases**

**RECOMMENDATION:**

**Review & Approve**

<u>NAME</u>	<u>REASON</u>	<u>TYPE NO.</u>
Harry R. Anderson	\$135.38 Refund-currently licensed- Paid taxes at DMV.	Pick/Up/18054 P-12105-15
Pauline Robertson (047)	\$303.61 Adjustment - Acreage correction un use.	Pick-Up/18062 R-88924-15
Walter Stanley Pritchard (5381)	\$10,092.42 Adjustment - Rollball-2012-2015	Pick-Up/18056 Multiple bills

<u>NAME</u>	<u>REASON</u>	<u>TYPE NO.</u>
Shirley W. Whitehurst	\$5,987.00 Roll back taxes - 2012-2014	Pick-Up/18076 Multiple bills
Elmer M. Butt	\$364.02 Correction assessment	Pick-Up/18075 R-87606-15
Danny L. Jones	\$272.03 Correction assessment	Pick-Up/18072 R-88223-15
John O. Venner ETAL	\$348.94 Correction assessment	Pick-Up/18071 R-93958-15
William David Dunavant, Jr.	\$545.79 Correction assessment	Pick-Up/18069 R-92403-15
Jill Kramer ETAL	\$172.33 Correction assessment	Pick-Up/18067 R-90728-15
Evelyn White Upton	\$367.40 Correction assessment	Pick-Up/18066 R-91728-15
Carolyn MCDaniel	\$352.37 Correction assessment	Pick-Up/18064 R-90898-15
George Swendell Butts	\$352.37 Correction assessment	Pick-Up/18063 R-94439-15



REFUNDS OVER \$100.00

ACS Tax System  
9/04/15 9:24:22

CAMDEN COUNTY

Refunds to be Issued by Finance Office

Refund\$	Remit To:	Reference:	Drawer/Transaction Info:
223.45	ABNER, MELVIN RANDOLPH 105 SOYFIELDS CT SOUTH MILLS NC 27976	2013 V 0045378 MILITARY EXEMPT	20150820 99 219583
131.21	AUTERY, DONALD L 117 CULPEPPER ROAD SOUTH MILLS NC 27976	2015 R 01-7080-00-08-6210.0000 overpayment	20150903 99 219740
255.76	CAROLYN MCDANIEL 119 CHANTILLY RD CAMDEN NC 27921	2011 R 02-8927-00-83-4439.0000 overpayment	20150903 99 219738
1,651.72	K & A FARMS INC. 204 OLD SWAMP ROAD SOUTH MILLS NC 27976	2014 P 0000398 VALUE CHANGE	20150820 99 219585
2,341.40	K & A FARMS INC. 204 OLD SWAMP ROAD SOUTH MILLS NC 27976	2011 P 0000398 VALUE CHANGE	20150820 99 219587
2,076.81	K & A FARMS INC. 204 OLD SWAMP ROAD SOUTH MILLS NC 27976	2012 P 0000398 VALUE CHANGE	20150820 99 219588
1,942.22	K & A FARMS INC. 204 OLD SWAMP ROAD SOUTH MILLS NC 27976	2013 P 0000398 VALUE CHANGE	20150820 99 219589
215.87	LITCHFIELD, WALTER C. 191 THOMAS POINT ROAD SHILOH NC 27974	2015 R 03-8971-00-12-0876.0000 overpayment	20150903 99 219746
310.53	NCHFPA 3508 BUSH STREET RALEIGH, NC 27609	2014 R 03-8961-00-69-3519.0000 overpayment Marietta Hughes	20150831 1 219700
562.48	WILLIAM H. MORGAN JR. ATTORNEY 410 E MAIN ST ELIZABETH CITY NC 27909	2015 R 03-8964-00-08-7781.0000 overpayment	20150903 99 219739
9,711.45	Total Refunds		

\*\*\*

Submitted by Lisa S. Anderson Date 9-4-15  
Lisa S. Anderson, Tax Administrator Camden County

Approved by \_\_\_\_\_ Date \_\_\_\_\_  
P. Michael McLain, Chairman Camden County Board of Commissioners

**Camden County Board of Commissioners  
AGENDA ITEM SUMMARY SHEET**

**Item Number: 6.D**

**Consent Agenda**

**Meeting Date: September 21<sup>st</sup>, 2015**

**Attachments: 1**

**Submitted By: Tax Office**

**ITEM TITLE: Authorization to Collect**

<b>MOTION MADE BY:</b>	
S. Duckwall	
G. Meiggs	
M. McLain	
C. Riggs	
T. White	
NO MOTION	
<b>VOTE:</b>	
S. Duckwall	
G. Meiggs	
M. McLain	
C. Riggs	
T. White	
ABSENT	
RECUSED	

**SUMMARY:**

**Authorization to Collect – November Renewals**

**RECOMMENDATION:**

**Review & Approve**

**STATE OF NORTH CAROLINA**

**COUNTY OF CAMDEN**

**TO:** The Tax Administrator of Camden County November Ren. Due 12/15/15 (NEW SYSTEM)

You are hereby authorized, empowered, and commanded to collect the taxes set forth in the tax records filed in the office of the Tax Administrator and in the tax receipts herewith delivered to you, in the amounts and from the taxpayers likewise therein set forth. Such taxes are hereby declared to be a first lien upon personal property of the respective taxpayers in the County of Camden, and this order shall be a full and sufficient authority to direct, require, and enable you to levy on and sell personal property of such taxpayers for and on account thereof, in accordance with the law.

<b>SOUTH MILLS</b>	<b>COURTHOUSE</b>	<b>SHILOH</b>	<b>TOTAL</b>
14,765.26	15,253.62	7,350.08	37,368.96

Witness my hand and official seal this \_\_\_\_\_ day of \_\_\_\_\_

\_\_\_\_\_  
Chairman, Camden County Board of Commissioners

Attest:

\_\_\_\_\_  
Clerk to the Board of Commissioners of Camden County

This is to certify that I have received the tax receipts and duplicates for collection in the amounts as listed herein.

  
\_\_\_\_\_  
Tax Administrator of Camden County

**Camden County  
South Camden Water & Sewer District**

**AGENDA ITEM SUMMARY SHEET**

**Item Number: 4.A**

**Consent Agenda**

**Meeting Date: 9/21/15**

**Attachments: 1 (Attachment B)**

**Submitted By: Clerk to the Board**

**ITEM TITLE: Draft Meeting Minutes**

<b>MOTION MADE BY:</b>	
S. Duckwall	
G. Meiggs	
M. McLain	
C. Riggs	
T. White	
NO MOTION	
<b>VOTE:</b>	
S. Duckwall	
G. Meiggs	
M. McLain	
C. Riggs	
T. White	
ABSENT	
RECUSED	

**SUMMARY:**

**July 6th 2015**

**RECOMMENDATION:**

**Approval.**

**Camden County  
South Camden Water & Sewer District**

**AGENDA ITEM SUMMARY SHEET**

**Item Number: 5.A**

**New Business**

**Meeting Date: 9/21/15**

**Attachments: 1 (109 Pages)**

**Submitted By: David Credle, Public Works  
Manager**

**ITEM TITLE: Water System Specifications**

<b>MOTION MADE BY:</b>	
S. Duckwall	
G. Meiggs	
M. McLain	
C. Riggs	
T. White	
NO MOTION	
<b>VOTE:</b>	
S. Duckwall	
G. Meiggs	
M. McLain	
C. Riggs	
T. White	
ABSENT	
RECUSED	

**SUMMARY:**

**Water system specifications for review and approval.**

**RECOMMENDATION:**

**Approval.**

# STANDARD SPECIFICATIONS AND DETAILS

For The

## **South Camden Water & Sewer District**

Camden County, North Carolina



**July 23, 2015**



Technical Specifications & Details  
For The  
**South Camden Water & Sewer District**  
Camden County, North Carolina

**ENGINEER**



Eastern Carolina Engineering, PC  
License C-4162

154 US Highway 158 East  
P.O. Box 128  
Camden, NC 27921  
(252) 335-1888 PHONE (252) 331-2390 FAX

Principal Engineer: Sean C. Robey, PE ([sean@easterncarolinainc.com](mailto:sean@easterncarolinainc.com))

July 23, 2015

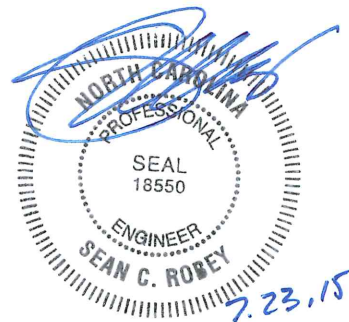





## TABLE OF CONTENTS

Section	Title
---------	-------

### **DIVISION 31 – EARTHWORK**

31 00 00	Earthwork
31 10 00	Site Clearing
31 23 17	Trenching and Backfilling
31 25 13	Erosion Controls
31 37 00	Riprap

### **DIVISION 32 – SITEWORK**

32 92 19	Seeding
----------	---------

### **DIVISION 33 - UTILITIES**

33 05 23	Jack and Bore
33 05 24	Horizontal Directional Drilling
33 11 00	Water Utility Distribution
33 13 00	Disinfecting of Water Distribution

### **STANDARD DETAILS**

1. Benched Water and Sewer
2. Water and Sewer Crossing
3. 2" Blow-off
4. Temporary Blow-off
5. Culvert Crossing
6. Hydrant Ditch Crossing
7. Fire Hydrant
8. Road Bore – Steel Casing
9. Tapping Detail
10. Thrust Blocking
11. Valve Box
12. Valve Marker
13. 3/4" Service Lateral
14. 1" Service Lateral



## SECTION 31 00 00

## EARTHWORK

## PART 1 GENERAL

## 1.1 RELATED DOCUMENTS

- A. The Proposal-Agreement Section of the Contract and other sections of this Division apply to the work in this Section.

## 1.2 SUMMARY

- A. Section Includes:
  - 1. Preparing and grading sub-grades for slabs on grade, walks, pavements, and landscaping.
  - 2. Base course for pavements.
  - 3. Excavating and backfilling for utility trenches.
  - 4. Erosion and sediment control measures.

## 1.3 DEFINITIONS

- A. Off-Site Select Borrow: Approved soil material obtained off-site when specified or when sufficient approved soil material is not available from excavations.
- B. Unsuitable Soil: Soil produced from excavation of drainage features, cut to sub-grade, or required stripping that does not meet the definition and requirements of suitable soil.
- C. Suitable Soil: Soil produced from excavation of drainage features, cut to sub-grade, or required stripping that meets the definition and requirements of suitable soil.
- D. Topsoil: Soil produced from stripping the top or upper 4-8" soil layer from areas to be further excavated, re-landscaped, or re-graded without contamination from the subsoil. Stripping of topsoil is not required where excavation width is less than 10' or for the installation of pipe utilities. Topsoil shall be stockpiled on site at designation location for further use. Topsoil shall not be removed from site.
- E. Backfill: Soil material or controlled low-strength material used for fill and excavation.
- F. Base Course: The layer placed between the sub-grade and surface pavement in a paving system.
- G. Excavation: Removal of material encountered above sub-grade elevations and to the lines and dimensions indicated.
- H. Fill: Soil materials used to raise existing grades.

- I. Porous Fill: Fill material supporting the slab on grade that also minimizes upward capillary flow of water.
- J. Structures: Buildings, slabs, curbs, utility appurtenances, tanks, retaining walls or other man-made stationary features constructed above or below ground surface.
- K. Sub-grade: The uppermost surface of an excavation or the top surface of a fill or backfill immediately below topsoil materials.
- L. Unauthorized excavation: Removal of materials beyond indicated sub-grade elevations or dimensions without direction by the Public Works Department and/or Engineer. Unauthorized excavation, as well as remedial work directed by the Public Works Department and/or Engineer, shall be at the Contractor's expense.
- M. Undercut excavation: Excavation below sub-grade elevations or beyond indicated lines and dimensions as directed by the Public Works Department and/or Engineer. Authorized undercut excavation and replacement material will be paid for according to Contract unit price for UNDERCUT and BACKFILL.
- N. Utilities: On-site underground pipes, conduits, ducts and cables.

#### 1.4 SUBMITTALS

- A. Material Test Reports: Interpreted test results from a qualified testing agency shall be submitted indicating compliance of test results with the following indicated requirements:
  - 1. Classification according to ASTM D 2487 of each on-site and borrow soil material proposed for fill and backfill.
  - 2. Laboratory compaction curve according to ASTM D 698 for each on-site and borrow soil material proposed for fill and backfill.
- B. Manufacturer's data on detectable warning tape.

#### 1.5 QUALITY ASSURANCE

- A. Perform work and provide materials in accordance with North Carolina Department of Transportation Standard Specifications for Roads and Structures, latest edition.
- B. North Carolina Erosion and Sediment Control Planning and Design Manual.
- C. Geotechnical Testing Agency Qualifications: An independent testing agency qualified according to ASTM E 329 to conduct soil materials and rock-definition testing, as documented according to ASTM D 3740 and ASTM E 548.

## PART 2 PRODUCTS

### 2.1 SOIL MATERIALS

- A. General: Provide borrow soil materials when sufficient suitable soil materials are not available from excavations.
- B. Suitable Soils: ASTM D 2487 Soil Classification Groups GW, GP, GM, GC, SW, SP, and SM or a combination of these groups; free of: rock or gravel larger than 1-1/2 inches in any dimension, debris, waste, frozen materials, vegetation, and other matter.
- C. Unsuitable Soils: ASTM D 2487 Soil Classification Groups SC, ML, CL, OL, MH, CH, OH, and PT or a combination of these groups.
  - 1. Unsuitable soils also include suitable soils not maintained within 2 percent of optimum moisture content at time of compaction and all soils not meeting the requirements for suitable soils.
- D. Porous Fill: ASTM D 2487 soil classification groups GW, GP, SW, or SP with a maximum aggregate size of 1.0 inch and no more than 5 percent passing the No. 200 sieve.
- E. Sand: ASTM C 33; fine aggregate, natural, or manufactured sand.
- F. Utility/Stone Bedding Material: NCDOT #67 or #57.
- G. Aggregate Base Course Material: NCDOT ABC.

### 2.2 ACCESSORIES

- A. Detectable Warning Tape for Metallic and Nonmetallic Pipe Materials: Acid- and alkali-resistant polyethylene film warning tape manufactured for marking and identifying underground utilities, 6 inches wide and 4 mils thick minimum, continuously inscribed with a description of the utility, with metallic core encased in a protective jacket for corrosion protection, detectable by metal detector when tape is buried up to 2' 6" deep.
- B. Tape Colors: Provide tape colors to utilities as follows:
  - 1. Red: Electric.
  - 2. Yellow: Gas.
  - 3. Orange: Telephone and other communications.
  - 4. Blue: Water systems.
  - 5. Green: Sanitary Sewer and Storm Sewer systems.
  - 6. Brown: Sewer Force Mains.

## PART 3 EXECUTION

### 3.1 EXAMINATION AND PREPARATION

- A. Call NC One Call service at 811 not less than three working days before performing work.
- B. Identify required lines, levels, contours, and datum locations.
- C. Notify the Public Works Department and/or Engineer of unexpected subsurface conditions and discontinue affected work in area until notified to resume work.
- D. Maintain and protect existing utilities indicated to remain.
- E. Preparation of sub-grade for earthwork operations, including removal of vegetation, topsoil, debris, obstructions, and materials from ground surface, is specified in Section 31 10 00 Site Clearing.

### 3.2 PROTECTION

- A. Barricade open holes and depressions occurring as part of the work, and post warning lights on barricades adjacent to the excavation. Operate warning lights from dusk to dawn and as otherwise required.
- B. Protect structures, utilities, sidewalks, pavements, and other facilities from damage caused by settlement, lateral movement, undermining, washouts, and other hazards created by earthwork operations.
- C. Protect and maintain erosion and sedimentation controls.
- D. Underpin adjacent structures which may be damaged by excavation work, including service utilities and pipe chases.

### 3.3 DEWATERING

- A. Prevent surface water and groundwater from entering excavations, from ponding on prepared sub-grades, and from flooding project site and surrounding area.
- B. Grade excavation top perimeter to prevent surface water run-off into excavation or to adjacent properties.
- C. Protect sub-grades from softening, undermining, washout, and damage by rain or water accumulation.
  - 1. Reroute surface water runoff away from excavated areas. Do not allow water to accumulate in excavations.
  - 2. Establish and maintain temporary drainage ditches and other diversions outside excavation limits to convey rain water and water removed from excavation as temporary drainage ditches.
  - 3. Do not use excavated trenches as temporary drainage ditches.

- D. Maintain the water level below the excavation sub-grade during excavation and construction.
  - 1. Material disturbed below the foundation sub-grade due to improper dewatering shall be removed and replaced with stone bedding material at no expense to the Owner.
  - 2. Dewatering by trench pumping will not be permitted if migration of fine grained natural material (running sand) from bottom, side walls, or bedding material will occur.
- E. Dispose of water pumped from excavations into ditches or storm drains having the capacity to handle the volume of pumped water.
  - 1. Contractor is responsible for acquiring all permits required to discharge the water and shall protect waterways from turbidity during the operation.
  - 2. Prevent flooding of streets, roadways, or private property.
  - 3. Provide noise attenuated engines when pumps will operate within 500 feet of a residence or commercial establishment.

### 3.4 TOPSOIL EXCAVATING

- A. Excavate topsoil and stockpile in area designated on site.

### 3.5 SUBSOIL EXCAVATING

- A. Remove groundwater by pumping to keep excavations dry.
- B. Excavate subsoil to sub-grade elevations regardless of the conditions encountered.
- C. Slope banks to angle of repose or less, until shored.
- D. Do not interfere with 45 degree bearing splay of foundations.
- E. Proof roll bearing surfaces.
- F. Correct unauthorized excavation at no cost to Owner.
- G. Fill over-excavated areas under structure bearing surfaces in accordance with direction by the Public Works Department and/or Engineer.
- H. Deposit soil in on-site stockpile locations as designated on the Drawings unless otherwise directed by the Public Works Department and/or Engineer.
- I. Refer to Section 31 23 17 Trenching and Backfilling for trenching specifications. Project-specific trenching specifications are also located in that section.

### 3.6 EXCAVATION AND TRENCH SAFETY

- A. During excavations, material suitable for backfilling shall be piled in an orderly manner a sufficient distance from the banks of the trench to avoid overloading, to prevent slides or cave-ins, and to provide adequate access to the work. The Contractor shall comply with



the “Rules and Regulations Governing the Construction Industry” as promulgated for the Health, Safety & General Welfare of Employees by the Commission of Labor. Particular attention shall be paid to the following sections:

1. Where unstable material is encountered in excavations over 5’ in depth, the sides of the excavations shall be shored or sheet piled unless the sides are sufficiently sloped to eliminate all possibility of a cave-in.
  2. Where stable material is encountered in excavations over 5’ in depth, the sides of the excavations shall be shored or braced unless the sides are sufficiently sloped to eliminate all possibility of a cave-in.
  3. Where workmen are engaged near the edge of the excavation, undercutting of bank or walls is prohibited unless adequately protected.
  4. Proper and adequate means of ingress and egress shall be provided at all times from all excavations and trenches; either by ramps, stairways, or ladders located so as to be accessible to workmen at all times.
- B. In addition to the Safety Provisions specified herein, the Contractor shall comply with the Department of Labor, Safety & Health Regulations for Construction promulgated under the Occupational & Health Act of 1970 (PL-596) and under Section 107 of the Contract Work Hours and Safety Standards Act (PL-91-54). Where the requirements of these acts are in excess of those requirements specified, the requirements of these acts shall govern.

### 3.7 STORAGE OF MATERIALS

- A. Stockpile off-site select borrow and excavated suitable soil materials without intermixing. Place, grade, and shape stockpiles to drain surface water. Stockpile height should not exceed 15’ and slope should be 2:1 or flatter. Cover to prevent windblown dust.
- B. Stockpile soil materials away from edge of excavations. Do not store within drip line of remaining trees.
- C. Materials which are excavated shall be placed so that the base of the pile is not less than 2’ from the edge of the excavation.

### 3.8 BACKFILLING TRENCHES

- A. Prior to backfilling, remove all debris, trash, organic material, formwork, temporary shoring and bracing from excavation. Perform all testing and inspection of underground utilities.
- B. Place and compact initial backfill of suitable soil material or sub-base material, free of particles larger than 1 inch, to a height of 12 inches over the utility.
- C. Carefully compact material under pipe haunches. Bring backfill up evenly on both sides and along the full length of utility piping or conduit to avoid damage or displacement of utility system.
- D. Install warning tape directly above utilities at 12” below final grade, except 6” below sub-grade under paved areas and slabs.

- E. Fill backfill areas to contours and elevations. Use unfrozen and unsaturated materials.
- F. Backfill systematically, as early as possible, to allow maximum time for natural settlement. Do not backfill over porous, wet, frozen, or spongy sub-grade surfaces.
- G. Place material in continuous layers as follows:
  1. Borrow Materials: Maximum 8 inches compacted depth.
  2. Fill Materials: Maximum 8 inches compacted depth.
- H. Maintain optimum moisture content of backfill materials to attain required compaction density.
  1. Uniformly moisten or aerate sub-grade and each subsequent fill or backfill soil layer to within 2 percent of optimum moisture content before compaction.
  2. Remove and replace, or scarify and air dry otherwise suitable soil material that exceeds optimum moisture content by 2 percent and is too wet to compact to specified dry unit weight.

### 3.9 PLACING FILL

- A. Preparation: Remove vegetation, topsoil, debris, wet and unsuitable soil materials, obstructions, and deleterious materials from ground surface prior to placing fills.
- B. Plow strip, or break up sloped surfaces steeper than 1 vertical to 4 horizontal so fill material will bond with existing surface.
- C. When sub-grade or existing ground surface to receive fill has a density less than that required for fill, break up ground surface to depth required, pulverize, moisten, or aerate soil, and re-compact to required density.
- D. Place fill material in layers to required elevations for each location listed below.
  1. Under grass, use excavated suitable soil or off-site select borrow to 4" below finished grade, and then fill with topsoil to grade.
  2. Under pavements, use base material, and excavated suitable soil or off-site select borrow.
  3. Under walks and ramps, use excavated suitable soil or off-site select borrow.
- E. Maintain moisture content of fill material by moistening or aerating to within 2% of optimum.

### 3.10 BASE COURSE

- A. Under pavements, place base course material on prepared sub-grades as soon as possible after proof-rolling.
- B. Compact base course at optimum moisture content to required grades, lines, cross-sections and thicknesses to not less than 95% maximum density.
- C. Shape base to required crown elevations and cross-slope grades.

- D. When thickness of compacted base course is 6 inches or less, place materials in a single layer.
- E. When thickness of compacted base course exceeds 6 inches, place materials in equal layers, with no layer more than 6 inches thick or less than 3 inches thick when compacted.

### 3.11 PLACING TOPSOIL

- A. Place topsoil in areas where seeding, sodding, or planting is scheduled.
- B. Fine grade topsoil to eliminate rough or low areas. Maintain levels, profiles, and contours of sub-grade.
- C. Remove large stones, roots, grass, weeds, debris, and foreign materials while spreading.
- D. Lightly compact placed topsoil.
- E. Leave stockpile area and site clean, raked, and ready to receive landscaping.

### 3.12 COMPACTION

- A. Place backfill and fill materials in layers not more than 12 inches in loose depth for material compacted by heavy compaction equipment, and not more than 4 inches in loose depth for material compacted by hand-operated tampers.
- B. Place backfill and fill materials evenly on all sides of structures to required elevations.
- C. Place backfill and fill uniformly along the full length of each structure.
- D. Percentage of Maximum Dry Density Requirements: Compact soil to not less than the following percentages of maximum dry density according to ASTM D 698:
  - 1. Under structures and pavements, compact the top 12 inches below sub-grade and each layer of backfill or fill material at 98 % maximum dry density.
  - 2. Under walkways, compact the top 6 inches below sub-grade and each layer of backfill or fill material at 95 percent maximum dry density.
  - 3. Under lawn or unpaved areas, compact the top 6 inches below sub-grade and each layer of backfill or fill material at 90 % maximum dry density.

### 3.13 TESTS

- A. Testing Agency Services: Owner will engage a qualified independent testing agency to perform field inspections and tests and to prepare test reports. Allow testing agency to inspect and test each sub-grade and each fill or backfill layer. Do not proceed until test results for previously completed work verify compliance with requirements.
- B. Perform laboratory material tests in accordance with ASTM D698 (Standard Proctor).
- C. Perform in place compaction tests in accordance with the following:

1. Density Tests: ASTM D1556 (sand cone) or ASTM D2922 (nuclear) as applicable.

D. Frequency of Tests:

1. Building slab areas: At sub-grade and at each compacted fill and backfill layer, at least 1 test every 2000 sq. ft., but in no case less than 3 tests.
2. Parking areas and roadways: At sub-grade and at each compacted fill and backfill layer, perform at least one field in place density test every 5000 sq. ft. or less of paved area, but in no case less than 3 tests.
3. Trench backfill: In paved areas, test as above. In lawns and unpaved areas, test final backfill layer with one field in-place density test for each 250 feet of trench. In wooded, undeveloped areas, testing is not required.

- E. When testing agency reports that sub-grades, fills, or backfills are below specified density, scarify, moisten, aerate or replace soils and re-compact and re-test as necessary to achieve required density.

3.14 TOLERANCES

- A. Top Surface of Exposed Subgrade: Plus or minus one (1) inch.
- B. Top of Topsoil: Plus or minus one-half (1/2) inch.
- C. Where settling occurs during the project time, remove the finished surface, backfill with approved material, compact and re-install the finish surface. Restored surface shall match adjacent work to greatest extent possible.

END OF SECTION

## SECTION 31 10 00

### SITE CLEARING

#### PART 1 GENERAL

##### 1.1 RELATED DOCUMENTS

- A. The Proposal-Agreement Section of the Contract and other sections of this Division apply to the work in this Section.
- B. North Carolina Erosions and Sediment Control Planning and Design Manual.

##### 1.2 SUMMARY

- A. Section Includes:
  - 1. Removing surface debris.
  - 2. Removing designated paving, curbs, and concrete flatwork.
  - 3. Removing designated trees, shrubs, and other plant life.
  - 4. Capping and/or removing abandoned utilities.

##### 1.3 PAYMENT

- A. Basis of Measurement: By the Lump Sum
- B. Basis of Payment: By the unit price bid per Lump Sum for site clearing.

##### 1.4 QUALITY ASSURANCE

- A. Perform work in accordance with North Carolina Department of Transportation Standard Specifications for Roads and Structures, latest edition.
- B. A minimum of two persons shall be present at all times during tree clearing and grubbing operations. One shall be completely knowledgeable of the tree types involved, and shall direct the trimming of roots and limbs where required.

##### 1.5 JOB CONDITIONS

- A. Dust Control: During execution of the work included in this Section, use all means necessary to prevent the dissipation of dust; to prevent dust from becoming a nuisance to the public, neighbors, and performance of additional work on the site, thoroughly moisten all surfaces.
- B. Burning: Burning of combustible materials from demolished structures or vegetation will not be permitted on-site unless authorized by the Owner.
- C. Traffic: Conduct site clearing operations to ensure minimum interference with roads, streets, walks and other adjacent facilities. Do not close or obstruct roads, streets, walks

or other adjacent facilities without permission from authorities and notification of the Public Works Department and/or Engineer and Owner.

- D. Existing Conditions: It is recommended, but not required, that the Contractor video-tapes existing conditions of the right-of-way and adjacent properties prior to commencement of work.

## PART 2 PRODUCTS

- A. Temporary Barricades: Use only unused and solid lumber of utility grade or better to build temporary barricades surrounding the objects selected for protection, unless otherwise directed by the Public Works Department and/or Engineer.
- B. Pruning Paint: To treat cut or damaged plant tissue, apply only a pruning paint known to be formulated for horticultural applications and accepted by the Public Works Department and/or Engineer.
- C. Other Materials: Any other materials required for completion of the work this Section shall be selected by the Contractor and subject to approval by the Public Works Department and/or Engineer.

## PART 3 EXECUTION

### 3.1 EXAMINATION AND PREPARATION

- A. Notification: The Public Works Department and/or Engineer should be notified at least forty-eight (48) hours prior to beginning the work of this Section.
- B. Call NC One Call service at 811 not less than three (3) working days before performing Work.
  - 1. Request underground utilities to be located and marked within and surrounding construction areas.
- C. Verify the existing plant life designated to remain is tagged or identified.
- D. Identify stockpile locations for placing removed materials.

### 3.2 PROTECTION

- A. Ensure that utilities indicated to remain are located, identified, and protected from damage.
- B. Protect benchmarks, survey control points, and existing structures from damage or displacement.
- C. Heavy equipment and traffic shall be restricted from traveling over a proposed high-rate infiltration pond location except as necessary to perform clearing operations.

### 3.3 CLEARING

- A. Clearing and grubbing operations of construction sites, pipeline easements, and roadway areas, involve the removal of all vegetation and debris, including trees, logs, stumps, abandoned vehicles, obstacles, lumber, sawdust piles, fences, leaf piles, brick, tile, rubble, and masonry in the area of excavation, grade change, embankment construction, structure construction, or alteration and building construction, and all other such items as required for removal by the Public Works Department and/or Engineer.
- B. The Contractor shall pursue his operations in order to prevent damage to adjacent property and likewise to prevent bark, limb, or root injuries to trees, shrubs, or other types of vegetation which are to continue growing. When such injuries inevitably occur, all jagged edges of scarred areas shall be smoothed in compliance with standard horticultural practice, and the scars shall be concealed entirely with an asphaltum-based tree paint. All plants damaged by construction procedures to a degree which decimates their worth for shade or further landscape purposes, shall be cut and removed by the Contractor, with no additional compensation, if directed by the Public Works Department and/or Engineer.
- C. Timber shall not be cut by the Contractor beyond the clearing limits established by the Public Works Department and/or Engineer. Any timber to remain for landscape or erosion control purposes shall not be cut by the Contractor except when so directed by the Public Works Department and/or Engineer.
- D. The entire site for construction projects shall be enclosed in the clearing limits, excluding any specific locations on the drawings, unless otherwise directed by the Public Works Department and/or Engineer.
- E. Both permanent and construction easements shall be cleared for the pipeline and drainage easements as shown on the drawings, unless otherwise directed by the Public Works Department and/or Engineer.
- F. Healthy trees shall be cut at a height not exceeding six (6) inches above natural ground during the clearing of roadway areas where the depth of embankment surpasses six (6) feet in height, unless otherwise directed by the Public Works Department and/or Engineer.
- G. Trees shall be cut at or below the natural ground surface when trees are to be cut in areas not selected for grubbing.
- H. The process of grubbing shall be performed on all cleared areas excluding the following:
  - 1. Stumps within the area between permanent easements and construction easements may remain provided they are cut at or below the natural ground.
  - 2. Stumps shall not be grubbed nor be cut more than six (6) inches above the ground level, when the roadway embankment surpasses six (6) feet in height. Unsound or decayed stumps shall be removed to a minimum depth of two (2) feet below the natural ground surface.
  - 3. In designated clearing and/or grubbing areas, all holes and additional ruts shall be filled and the area brought to a satisfactory form allowing the Owner to mow the

area without difficulty. Execution of this work shall be a part of the clearing and grubbing operation despite whether the conditions were the results of the Contractor's actions or were present before construction.

4. Additional items which shall be removed from construction sites and permanent easement surfaces include the following: cans, rocks over two (2) inches in diameter, loose debris, bottles, bricks, etc.
  - I. All stumps and roots larger than 2" in diameter shall be completely removed by grubbing except in areas of the building site, parking areas and drives; they must be cut off no less than 18" below any sub-grade. The area of operation shall then be cleared of resulting debris and matted roots, weeds, and other organic material shall be hauled away from the site. Generally, all material that cannot be compacted to 90% density in lawn areas and 95% density elsewhere must be removed.

### 3.4 REMOVAL

- A. All timber of value, including pulp wood, that is required to be cut during the process of construction shall become property of the Contractor and shall be removed from the project site as described in these specifications.
- B. All non-value clearing and grubbing debris shall be removed from the property by the Contractor to an acceptable location as permitted by federal, state and local regulations.
- C. Partially remove paving, curbs, and concrete flatwork as indicated on Drawings. Neatly saw cut edges at right angle to surface.
- D. Remove abandoned utilities. Indicated removal termination point for underground utilities on Record Documents.
- E. Continuously clean-up and remove waste materials from site. Do not allow materials to accumulate on site.
- F. Do not burn or bury materials on site. Leave site in clean condition.

END OF SECTION



## SECTION 31 23 17

## TRENCHING AND BACKFILLING

## PART 1 GENERAL

## 1.1 RELATED DOCUMENTS

- A. The Proposal-Agreement Section of the Contract and other sections of this Division apply to the work in this Section.

## 1.2 SUMMARY

- A. Section Includes:
  - 1. Excavating trenches for utilities.
  - 2. Compacted fill from top of utility bedding sub-grades or finish grades.
  - 3. Backfilling and compaction.

## 1.3 MEASUREMENT AND PAYMENT

- A. Unclassified excavation:
  - 1. No measurement or direct payment will be made for the Work under this Section and all costs for same shall be included in the price bid for the utility or structure to which it pertains.

## 1.4 REFERENCES

- A. American Association of State Highway and Transportation Officials:
  - 1. AASHTO T180 - Standard Specification for Moisture-Density Relations of Soils Using a 4.54-kg (10-lb) Rammer and a 457-mm (18-in.) Drop.
  - 2. ASTM C136 - Standard Test Method for Sieve Analysis of Fine and Coarse Aggregates.
  - 3. ASTM D698 - Standard Test Method for Laboratory Compaction Characteristics of Soil Using Standard Effort (12,400 ft-lbf/ft<sup>3</sup> (600 kN-m/m<sup>3</sup>)).
  - 4. ASTM D1556 - Standard Test Method for Density of Soil in Place by the Sand-Cone Method.
  - 5. ASTM D1557 - Standard Test Method for Laboratory Compaction Characteristics of Soil Using Modified Effort (6,000 ft-lbf/ft<sup>3</sup> (2,700 kN-m/m<sup>3</sup>)).
  - 6. ASTM D2167 - Standard Test Method for Density and Unit Weight of Soil in Place by the Rubber Balloon Method.

7. ASTM D2922 - Standard Test Method for Density of Soil and Soil-Aggregate in Place by Nuclear Methods (Shallow Depth).

## 1.5 DEFINITIONS

- A. Off-Site Select Borrow: Approved soil material obtained off-site when specified or when sufficient approved soil material is not available from excavations.
- B. Unsuitable Soil: Soil produced from excavation of drainage features, cut to sub-grade, or required stripping that does not meet the definition and requirements of suitable soil.
- C. Suitable Soil: Soil produced from excavation of drainage features, cut to sub-grade, or required stripping that meets the definition and requirements of suitable soil.
- D. Topsoil: Soil produced from stripping the top or upper soil layer from areas to be further excavated, re-landscaped, or re-graded without contamination from the subsoil. Stripping of topsoil is not required where excavation width is less than 10' or for the installation of pipe utilities. Topsoil shall be stockpiled on site at designation location for further use. Topsoil shall not be removed from site.
- E. Backfill: Soil material or controlled low-strength material used for fill and excavation.
- F. Base Course: The layer placed between the sub-grade and surface pavement in a paving system.
- G. Excavation: Removal of material encountered above sub-grade elevations and to the lines and dimensions indicated.
- H. Fill: Soil materials used to raise existing grades.
- I. Porous Fill: Fill material supporting the slab on grade that also minimizes upward capillary flow of water.
- J. Structures: Buildings, slabs, curbs, utility appurtenances, tanks, retaining walls or other man-made stationary features constructed above or below ground surface.
- K. Sub-grade: The uppermost surface of an excavation or the top surface of a fill or backfill immediately below topsoil materials.
- L. Unauthorized excavation: Removal of materials beyond indicated sub-grade elevations or dimensions without direction by the Public Works Department and/or Engineer. Unauthorized excavation, as well as remedial work directed by the Public Works Department and/or Engineer, shall be at the Contractor's expense.
- M. Undercut excavation: Excavation below sub-grade elevations or beyond indicated lines and dimensions as directed by the Public Works Department and/or Engineer. Authorized undercut excavation and replacement material will be paid for according to Contract unit price for UNDERCUT and BACKFILL.

N. Utilities: On-site underground pipes, conduits, ducts and cables.

## 1.6 SUBMITTALS

- A. Material Test Reports: Interpreted test results from a qualified testing agency shall be submitted indicating compliance of test results with the following indicated requirements:
1. Classification according to ASTM D 2487 of each on-site and borrow soil material proposed for fill and backfill.
  2. Laboratory compaction curve according to ASTM D 698 for each on-site and borrow soil material proposed for fill and backfill.
- B. Excavation Protection Plan: Describe sheeting, shoring, and bracing materials and installation required to protect excavations and adjacent structures and property; include structural calculations to support plan.
- C. Manufacturer's data on detectable warning tape.

## 1.7 QUALITY ASSURANCE

- A. Perform work and provide materials in accordance with North Carolina Department of Transportation Standard Specifications for Roads and Structures, latest edition.
- B. North Carolina Erosion and Sediment Control Planning and Design Manual.
- C. Geotechnical Testing Agency Qualifications: An independent testing agency qualified according to ASTM E 329 to conduct soil materials and rock-definition testing, as documented according to ASTM D 3740 and ASTM E 548.

## 1.8 QUALIFICATIONS

- A. Use an adequate number of skilled workmen who are thoroughly trained and experienced in the necessary crafts and who are completely familiar with the specified requirements and the methods needed for proper performance of the work of this Section
- B. Use a sufficient number of equipment of adequate size and capacity to accomplish the work in a timely manner.

## 1.9 JOB CONDITIONS

- A. Existing Utilities:
1. The existence and locations of underground utilities indicated on the Contract Drawings are not guaranteed and shall be investigated and verified in the field by the Contractor before starting work. Excavations in the vicinity of existing structures and utilities shall be done carefully by hand.
  2. Locate existing utilities lines using an electronic pipe finder or other approved means. Uncover these utilities by hand excavation and provide protection from damage. Cooperate with Owner and utility companies for maintaining services. Do not break connections without providing temporary services, as acceptable to the Public Works Department and/or Engineer.

3. Locate, excavate, and expose all existing underground lines before beginning trenching operations.
4. The Contractor will be held responsible for the workmanlike repair of any damage done to any of these utilities in the execution of his work under this Section.
5. The Contractor shall familiarize himself with the existing conditions of these utilities. He shall be prepared to adequately safeguard himself, the utilities, and the Owner from damage.
6. Necessary arrangements shall be made by the Contractor with all persons, firms, corporations owning or using any poles, pipes, tracks or conduits, etc., affected by the construction included under this Section to maintain and protect such facilities during construction. The cost of any such protection shall be paid by the Contractor and included in the Contract price.
7. In the event that any existing gas pipes, water pipes, conduits, sewers, tile drains, poles or other utilities are blocked or interfered with by construction operations, the Contractor shall maintain them in continuous operation and restore them to the same condition as they were prior to the start of construction on this project, all at no additional compensation.

B. Utility Notification:

1. Call NC One Call service at 811 not less than three working days before performing work.

C. Protecting Trees, Shrubbery, and Lawns:

1. Trees and shrubbery in developed areas and along the trench line shall not be disturbed unless absolutely necessary and subject to the approval of the Public Works Department and/or Engineer.
2. Any trees and shrubbery for which removal is necessary shall be heeled in and replanted.
3. Where trenches cross private property through established lawns, sod shall be cut, removed, stacked and maintained in suitable condition until replacement is approved by the Public Works Department and/or Engineer.
4. Topsoil underlying lawn areas shall be removed and kept separate from general excavated materials.

D. Clearing:

1. Perform all clearing necessary for installation of the complete work.
2. Clearing shall be performed in accordance with Section 31 10 00 Site Clearing.

E. Removing and Resetting Fences:

1. Where existing fences must be removed to permit construction of utilities:
  - a. Remove such fences and, as the Work progresses, reset the fences in their original location and condition.
  - b. Fencing must be replaced at the end of each working day.

F. Restoration of Disturbed Areas:

1. Restore all areas disturbed by, during, or as a result of construction activities to their previous or better condition.

## 1.10 FIELD MEASUREMENTS

- A. Verify field measurements prior to fabrication.

## 1.11 COORDINATION

- A. Verify Work associated with lower elevation utilities is complete before placing higher elevation utilities.

## PART 2 PRODUCTS

### 2.1 SOIL MATERIALS

- A. Suitable Soils: ASTM D 2487 Soil Classification Groups GW, GP, GM, GC, SW, SP, and SM or a combination of these groups; free of: rock or gravel larger than 1-1/2 inches in any dimension, debris, waste, frozen materials, vegetation, and other matter.
- B. Unsuitable Soils: ASTM D 2487 Soil Classification Groups SC, ML, CL, OL, MH, CH, OH, and PT or a combination of these groups.
  - 1. Unsuitable soils also include suitable soils not maintained within 2 percent of optimum moisture content at time of compaction and all soils not meeting the requirements for suitable soils.
- C. Native material: Soils as excavated from the trench excavation. Where specifically directed by the Public Works Department and/or Engineer, native material may be used for trench backfill.
- D. Porous Fill: ASTM D 2487 soil classification groups GW, GP, SW, or SP with a maximum aggregate size of 1.0 inch and no more than 5 percent passing the No. 200 sieve.
- E. Sand: ASTM C 33; fine aggregate, natural, or manufactured sand.
- F. Utility/stone bedding material: NCDOT #67 or #57.
- G. Aggregate Base Course Material: NCDOT ABC.

### 2.2 EXCAVATED MATERIALS

- A. Perform all excavation of every description and of whatever substances encountered to depths indicated or specified.
- B. Pile material suitable for backfilling in an orderly manner at a safe distance from banks or trenches to avoid overloading and to prevent slides or cave-ins.
- C. Remove and deposit unsuitable or excess material as directed by the Public Works Department and/or Engineer.

## 2.3 ACCESSORIES

- A. Detectable Warning Tape for Metallic and Nonmetallic Pipe Materials:
  - 1. Acid- and alkali-resistant polyethylene film warning tape manufactured for marking and identifying underground utilities, 6 inches wide and 4 mils thick minimum, continuously inscribed with a description of the utility, with metallic core encased in a protective jacket for corrosion protection, detectable by metal detector when tape is buried up to 2'-6" deep.
  - 2. Example:       Color: Blue  
                          Text: "CAUTION – WATER LINE BURIED BELOW"
- B. Detectable Tracer Wire: At all locations where pressure piping is installed and at lateral locations, non-ferrous or ferrous materials, the contractor shall install a continuous length of #12 solid copper wire, on top and parallel to the pipe. Wire to be secured to pipe with tape.

## PART 3 EXECUTION

### 3.1 LINES AND GRADES

- A. Lay pipes to lines and grades indicated on Drawings.
  - 1. The Public Works Department and/or Engineer reserves right to make changes in lines, grades, and depths of utilities when changes are required for Project conditions.
- B. Use laser-beam instruments with qualified operator to establish lines and grades.

### 3.2 EXAMINATION AND PREPARATION

- A. Call NC One Call service at 811 not less than three working days before performing work.
- B. Identify required lines, levels, contours, and datum locations.
- C. Notify the Public Works Department and/or Engineer of unexpected subsurface conditions and discontinue affected work in area until notified to resume work.

### 3.3 PROTECTION OF UTILITIES

- A. Unless shown to be removed, protect active utility lines shown on the drawings or otherwise make them known to the Contractor prior to trenching. If damaged, repair or replace at no additional cost to the Owner.
- B. If active utility lines are encountered and are not shown on the Drawings or otherwise made known to the Contractor, promptly take necessary steps to assure that service is not interrupted.

- C. If service is interrupted as a result of work under this Section, immediately restore service by repairing the damaged utility at no additional cost to the Owner.
- D. If existing utilities are found to interfere with the permanent facilities being constructed under this Section, immediately notify the Public Works Department and/or Engineer and secure his instructions.
- E. Do not proceed with permanent relocation of utilities until written instructions are received from the Public Works Department and/or Engineer.
- F. Locations within streets or highways:
  - 1. Take all precautions and comply with all requirements as may be necessary to protect the improvements, including barricades for protection of traffic.
  - 2. Keep a minimum of one lane open to traffic at all times where utility crosses street or highway.

### 3.4 PROTECTION OF PERSONS AND PROPERTY

- A. Barricade open holes and depressions occurring as part of the Work, and post warning lights on property adjacent to or with public access.
- B. Operate warning lights during hours from dusk to dawn each day and as otherwise required.
- C. Protect structures, utilities, sidewalks, pavements, and other facilities from damage caused by settlement, lateral movement, washout and other hazards created by operations under this Section.
- D. Protect plant life, lawns, and other features remaining as portion of final landscaping.
- E. Protect benchmarks, existing structures, fences, sidewalks, paving, and curbs from excavating equipment and vehicular traffic.
- F. Establish temporary traffic control and detours, when necessary, when trenching is performed in public right-of-way. Relocate controls and reroute traffic as required during progress of Work.

### 3.5 DEWATERING

- A. Prevent surface water and groundwater from entering excavations, from ponding on prepared sub-grades, and from flooding project site and surrounding area.
- B. Protect sub-grades from softening, undermining, washout, and damage by rain or water accumulation.
  - 1. Reroute surface water runoff away from excavated areas. Do not allow water to accumulate in excavations.
  - 2. Establish and maintain temporary drainage ditches and other diversions outside excavation limits to convey rain water and water removed from excavation as temporary drainage ditches.

3. Do not use excavated trenches as temporary drainage ditches.
- C. Maintain the water level below the excavation sub-grade during excavation and construction.
1. Material disturbed below the foundation sub-grade due to improper dewatering shall be removed and replaced with stone bedding material at no expense to the Owner.
  2. Dewatering by trench pumping will not be permitted if migration of fine grained natural material (running sand) from bottom, side walls, or bedding material will occur.
- D. Dispose of water pumped from excavations into ditches or storm drains having the capacity to handle the volume of pumped water.
1. Contractor is responsible for acquiring all permits required to discharge the water and shall protect waterways from turbidity during the operation.
  2. Prevent flooding of streets, roadways, or private property.
  3. Provide noise attenuated engines when pumps will operate within 500 feet of a residence or commercial establishment.

### 3.6 TRENCHING

- A. Excavate for utilities to the lines and grades per the drawings.
- B. Cut trenches sufficiently wide to enable installation of utilities and allow inspection.
- C. Do not advance open trench more than 400 feet ahead of installed pipe.
- D. Excavate trenches to depth indicated on Drawings. Provide uniform and continuous bearing and support for bedding material and utility.
- E. Do not interfere with 45 degree bearing splay of foundations.
- F. When Project conditions permit, slope side walls of excavation starting 2 feet above top of pipe. When side walls cannot be sloped, provide sheeting and shoring to protect excavation as specified in this section.
- G. When subsurface materials at bottom of trench are loose or soft notify the Public Works Department and/or Engineer, and request instructions.
- H. Hand trim excavation and leave free of loose matter. Hand trim for bell and spigot pipe joints.
- I. Stockpile excavated material that is suitable for re-use as directed in 31 00 00 Earthwork, 3.7 Storage of Materials.
- J. Remove from site any excavated material that is unsuitable for re-use.
- K. Where trenching occurs in existing lawns, remove turf in sections and keep damp. Replace turf upon completion of the backfilling.



- L. Open cut:
1. Excavate for utilities by open cut.
  2. If conditions at the site prevent such open cut, and if approved by the Public Works Department and/or Engineer, tunneling may be used.
  3. Short sections of a trench may be tunneled if, in the opinion of the Public Works Department and/or Engineer, the conductor can be installed safely and backfill can be compacted properly into such tunnel.
- M. Special requirements relating to excavation for water distribution lines:
1. Do not excavate trench more than 400' ahead of pipe laying, unless permitted by the Public Works Department and/or Engineer
  2. Provide depth of cover shown or minimum cover of 36", whichever is greater.
  3. Where minimum cover only is required, carry excavations to depths necessary to properly grade the pipe on tangents and vertical curves as directed by the Public Works Department and/or Engineer.
  4. Provide minimum clearance of 6" between pipe walls and trench walls or sheeting and bracing lines.
  5. If minimum cover of 36" cannot be provided, then thermoplastic piping may not be used. Use ductile iron piping or other Public Works Department and/or Engineer-approved material.
  6. If an unacceptable bearing surface is encountered during excavation, notify the Public Works Department and/or Engineer immediately. The Public Works Department and/or Engineer may authorize excavation below invert elevation for the introduction of bedding material. Authorized undercut excavation and replacement material will be paid for according to Contract unit price for Undercut and Backfill.
  7. If authorized bedding material is off-site select borrow or stone bedding material, they shall be paid for according to the respective unit price.
  8. If bedding material is required, pipe must be supported during placement and compaction of such material.
- N. Correct over-excavated areas with compacted backfill as specified for authorized excavation or replace with fill concrete as directed by the Public Works Department and/or Engineer.

### 3.7 EXCAVATION AND TRENCH SAFETY

- A. During excavations, material suitable for backfilling shall be piled in an orderly manner a sufficient distance from the banks of the trench to avoid overloading, to prevent slides or cave-ins, and to provide adequate access to the work. The Contractor shall comply with the "Rules and Regulations Governing the Construction Industry" as promulgated for the Health, Safety & General Welfare of Employees by the Commission of Labor. Particular attention shall be paid to the following sections:
1. Where unstable material is encountered in excavations over 5' in depth, the sides of the excavations shall be shored or sheet piled unless the sides are sufficiently sloped to eliminate all possibility of a cave-in.
  2. Where stable material is encountered in excavations over 5' in depth, the sides of the excavations shall be shored or braced unless the sides are sufficiently sloped to eliminate all possibility of a cave-in.

3. Where workmen are engaged near the edge of the excavation, undercutting of bank or walls is prohibited unless adequately protected.
  4. Materials which are excavated shall be placed so that the base of the pile is not less than 2' from the edge of the excavation.
  5. Proper and adequate means of ingress and egress shall be provided at all times from all excavations and trenches; either by ramps, stairways, or ladders located so as to be accessible to workmen at all times.
- B. In addition to the Safety Provisions specified herein, the Contractor shall comply with the Department of Labor, Safety & Health Regulations for Construction promulgated under the Occupational & Health Act of 1970 (PL-596) and under Section 107 of the Contract Work Hours and Safety Standards Act (PL-91-54). Where the requirements of these acts are in excess of those requirements specified, the requirements of these acts shall govern.

### 3.8 BACKFILLING

- A. Prior to backfilling, remove all debris, trash, organic material, formwork, temporary shoring and bracing from excavation. Perform all testing and inspection of underground utilities.
- B. Place and compact initial backfill of suitable soil material or sub-base material, free of particles larger than 1 inch, to a height of 12 inches over the utility.
- C. Carefully compact material under pipe haunches. Bring backfill up evenly on both sides and along the full length of utility piping or conduit to avoid damage or displacement of utility system.
- D. Install warning tape directly above utilities at 12" below final grade, except 6" below sub-grade under paved areas and slabs.
- E. Fill backfill areas to contours and elevations. Use unfrozen and unsaturated materials.
- F. Backfill systematically, as early as possible, to allow maximum time for natural settlement. Do not backfill over-porous, wet, frozen, or spongy sub-grade surfaces.
- G. Initial Backfill:
  1. Place approved backfill and bedding material in layers of 8 inches maximum thickness, unless otherwise approved and compact with suitable tampers to the density of the adjacent soil until there is cover of not less than 24" over sewers and 12" over other utilities.
- H. Remainder of backfill:
  1. Wooded, undeveloped areas and swamps:
    - a. Place approved backfill and bedding material in layers of 12-18" maximum thickness, and compact with suitable tampers.
    - b. Tamping may be ceased when backfill exceeds 30" over the pipe.
    - c. Mound excess material 6" above grade to provide for settlement.
  2. Lawns and unpaved areas:

- a. Place approved backfill and bedding material in layers of 12-18" maximum thickness, and compact with suitable tampers.
    - b. Obtain a compaction of 90% of maximum dry density.
  - 3. Paved areas, slabs on grade, site concrete flatwork and other similar areas:
    - a. Place approved backfill and bedding material in layers of 8 inches maximum thickness, and thoroughly compact with heavy duty mechanical tampers.
    - b. Obtain a compaction of 98% of an ASTM D698 Standard Proctor.
- I. Maintain optimum moisture content of backfill materials to attain required compaction density.
  - 1. Uniformly moisten or aerate sub-grade and each subsequent fill or backfill soil layer to within 2 percent of optimum moisture content before compaction.
  - 2. Remove and replace, or scarify and air dry otherwise suitable soil material that exceeds optimum moisture content by 2 percent and is too wet to compact to specified dry unit weight.
- J. Do not leave more than 20 feet of trench open at end of working day.
- K. Protect open trench to prevent danger to the public.

### 3.9 TOLERANCES

- A. Top Surface of Backfilling Under Paved Areas: Plus or minus one (1) inch required elevations.
- B. Top Surface of General Backfilling: Plus or minus one (1) inch from required elevations.

### 3.10 FIELD QUALITY CONTROL

- A. Testing Agency Services: Owner will engage a qualified independent testing agency to perform field inspections and tests and to prepare test reports. Allow testing agency to inspect and test each sub-grade and each fill or backfill layer. Do not proceed until test results for previously completed work verify compliance with requirements.
- B. Perform laboratory material tests in accordance with ASTM D698 (Standard Proctor).
- C. Perform in place compaction tests in accordance with the following:
  - 1. Density Tests: ASTM D1556 (sand cone) or ASTM D2922 (nuclear) as applicable.
- D. Frequency of Tests:
  - 1. Building slab areas: At sub-grade and at each compacted fill and backfill layer, at least 1 test every 2000 sq. ft., but in no case less than 3 tests.
  - 2. Parking areas and roadways: At sub-grade and at each compacted fill and backfill layer, perform at least one field in place density test every 5000 sq. ft. or less of paved area, but in no case less than 3 tests.
  - 3. Trench backfill: In paved areas, test as above. In lawns and unpaved areas, test final backfill layer with one field in-place density test for each 250 feet of trench. In wooded, undeveloped areas, testing is not required.

- E. When testing agency reports that sub-grades, fills, or backfills are below specified density, then scarify, moisten, aerate, or replace soils. Re-compact and re-test as necessary to achieve required density.

3.11 PROTECTION OF FINISHED WORK

- A. Reshape and re-compact fills subjected to vehicular traffic during construction.

END OF SECTION

SECTION 31 25 13  
EROSION CONTROLS

PART 1 GENERAL

1.1 RELATED DOCUMENTS

- A. The Proposal-Agreement Section of the Contract and other sections of this Division apply to the work in this Section.
- B. North Carolina Erosions and Sediment Control Planning and Design Manual.

1.2 SUMMARY

- A. Section Includes:
  - 1. Stone Check Dam
  - 2. Temporary Gravel Construction Entrance
  - 3. Silt Fence
  - 4. Rock Energy Dissipater
  - 5. Block and Gravel Inlet Protection

1.3 MEASUREMENT AND PAYMENT

- A. Stone Check Dam
  - 1. Basis of Measurement: Per Each installed.
  - 2. Basis of Payment: Includes necessary excavation, riprap, filter stone and required maintenance throughout the Contract time.
- B. Temporary Gravel Construction Entrance
  - 1. Basis of Measurement: Per Each installed.
  - 2. Basis of Payment: Includes site clearing, stripping, excavating, backfilling, placing rock, and required maintenance throughout the Contract time.
- C. Silt Fence
  - 1. Basis of Measurement: By Linear Foot of silt fence installed.
  - 2. Basis of Payment: Includes excavating, vegetation removal, installation and continued maintenance throughout the Contract time.
- D. Rock Energy Dissipater
  - 1. Basis of Measurement: Per SY of riprap installed to depth as indicated on drawings and details.
  - 2. Basis of Payment: Includes excavating, removing unsuitable material, backfilling, placing geotextile fabric, placing riprap, backfilling edges and continued maintenance throughout the Contract time.

- E. Block and Gravel Inlet Protection
  - 1. Basis of Measurement: Block and gravel inlet protection is to be included in the unit price paid for the corresponding drainage structure.
  - 2. Basis of Payment: Block and gravel inlet protection is to be included in the unit price paid for the corresponding drainage structure. No separate payment will be made.
- F. Rock Pipe Inlet Protection
  - 1. Basis of Measurement: Per Each installed.
  - 2. Basis of Payment: Includes necessary excavation, riprap, filter stone and required maintenance throughout the Contract time.
- G. Riprap Channel Lining
  - 1. Basis of Measurement: Per SY of riprap installed to the depth as indicated on drawings and details.
  - 2. Basis of Payment: Includes excavating, removing unsuitable material, backfilling, placing geotextile fabric, placing riprap, backfilling edges, and continued maintenance throughout the Contract time.

#### 1.4 REFERENCES

- A. American Association of State Highway and Transportation Officials:
  - 1. AASHTO T88 - Standard Specification for Particle Size Analysis of Soils.
  - 2. AASHTO T180 - Standard Specification for Moisture-Density Relations of Soils Using a 4.54-kg (10-lb) Rammer and a 457-mm (18-in.) Drop.
- B. American Concrete Institute:
  - 1. ACI 301 - Specifications for Structural Concrete.
- C. ASTM International:
  - 1. ASTM C127 - Standard Test Method for Specific Gravity and Absorption of Coarse Aggregate.
  - 2. ASTM D698 - Standard Test Method for Laboratory Compaction Characteristics of Soil Using Standard Effort (12,400 ft-lbf/ft<sup>3</sup> (600 kN-m/m<sup>3</sup>)).
  - 3. ASTM D1557 - Standard Test Method for Laboratory Compaction Characteristics of Soil Using Modified Effort (6,000 ft-lbf/ft<sup>3</sup> (2,700 kN-m/m<sup>3</sup>)).
  - 4. ASTM D2922 - Standard Test Method for Density of Soil and Soil-Aggregate in Place by Nuclear Methods (Shallow Depth).
  - 5. ASTM D3017 - Standard Test Method for Water Content of Soil and Rock in Place by Nuclear Methods (Shallow Depth).
- D. Precast/Prestressed Concrete Institute:
  - 1. PCI MNL-116S - Manual for Quality Control for Plants and Production of Precast and Prestressed Concrete Products.

#### 1.5 SUBMITTALS

- A. Geotextile fabric

- B. Filter fabric

## 1.6 QUALITY ASSURANCE

- A. Perform Work in accordance with requirements of Section 31 00 00 – Earthwork, Section 31 10 00 – Site Clearing, and Section 31 37 00 – Riprap.
- B. Perform work and provide materials in accordance with North Carolina Department of Transportation Standard Specifications for Roads and Structures, July 2006 edition.
- C. North Carolina Erosion and Sediment Control Planning and Design Manual.
- D. Geotechnical Testing Agency Qualifications: An independent testing agency qualified according to ASTM E 329 to conduct soil materials and rock-definition testing, as documented according to ASTM D 3740 and ASTM E 548.

## PART 2 PRODUCTS

### 2.1 ROCK AND GEOTEXTILE MATERIALS

- A. Furnish materials and rock in accordance with North Carolina Department of Transportation Standard Specifications for Roads and Structures, July 2006 edition.
- B. Geotextile Fabric: Manufacturer's standard non-woven pervious geotextile fabric of polypropylene, nylon or polyester fibers, or a combination.
  - 1. Provide geotextile fabrics that meet or exceed the listed minimum physical properties determined according to ASTM D 4759 and the referenced standard test method in parentheses:
    - a. Grab Tensile Strength (ASTM D 4632): 200 lb.
    - b. Apparent Opening Size (ASTM D 4751): #60 U.S. Standard sieve.
  - 2. Acceptable geotextile fabrics include: Propex Geotex® 801 or approved equal.
- C. Filter Fabric: Manufacturer's standard woven pervious geotextile fabric of polypropylene, nylon or polyester fibers, or a combination.
  - 1. Provide filter fabrics that meet or exceed the listed minimum physical properties determined according to ASTM D 4759 and the referenced standard test method in parentheses:
    - a. Standard-strength filter fabric:
      - 1) Grab Tensile Strength (ASTM D 4632): 50 lb.
      - 2) Elongation (ASTM D 4632): 30% maximum.
      - 3) Apparent Opening Size (ASTM D 4751): #30 U.S. Standard sieve.
      - 4) Permittivity (ASTM D 4491): 0.15/sec.
    - b. Extra-strength filter fabric:
      - 1) Grab Tensile Strength (ASTM D 4632): 100 lb.
      - 2) Elongation (ASTM D 4632): 25% maximum.

- 3) Apparent Opening Size (ASTM D 4751): #30 U.S. Standard sieve.
  - 4) Permittivity (ASTM D 4491): 0.15/sec.
- c. Propex Geotex® 102F satisfies both sets of requirements and may be used for silt fence construction; however, an approved equal may also be substituted.

## 2.2 CONCRETE MASONRY UNITS

- A. Concrete masonry units shall conform to ATSM C90.
- B. Unit compressive strength: Provide units with a minimum average net-area compressive strength of 1900 psi.
- C. Weight Classification: Lightweight.
- D. Size: 8"x8"x16" nominal. Manufactured to dimensions 3/8" less than nominal.

## 2.3 ACCESSORIES

- A. Mortar and Grout: (Per NCDOT 1040-8)
  1. Portland cement: ASTM C 150, Type I or II.
  2. Hydrated lime: ASTM C 207, Type S.
  3. Masonry cement not permitted.
  4. Mortar Cement: ASTM C 1329.
  5. Aggregate for mortar: ASTM C 144.
  6. Aggregate for grout: ASTM C 404.
  7. Mortar: 1 part Portland cement, 1/4 part hydrated lime, 3-3/4 parts mortar sand (max), water.
  8. Grout: 1 part Portland cement, 3 parts mortar sand, water.
- B. Steel Plate and Bar, Channels, Angles, M and S shapes: ASTM A 36.
- C. Welding Electrodes: Comply with AWS requirements.

## PART 3 EXECUTION

### 3.1 STONE CHECK DAM

- A. Construction
  1. Immediately following ditch excavation, install stone check dams where indicated on the drawings.
  2. Ditch bottom shall be firm, unyielding, and free of loose sediment.
  3. Place NCDOT Class B riprap in ditch from top of bank to top of bank, sloping at 2:1 upstream and downstream. Provide a 6" depression in the riprap at the center point of the ditch.
  4. Line the upstream edge of the stone check dam with a 12" thick layer of NCDOT #5 or #57 stone from the bottom of the ditch to the top of the riprap.



B. Maintenance

1. Inspect stone check dams immediately following all rainfall events.
2. Remove sediment buildup from front of check dam when sediment height reaches one third (1/3) the height of the dam.
3. If the stone becomes matted with soil material to the extent that the drainage through the stone deteriorates, the contaminated stone shall be removed from the site to an approved location and replaced with new stone at no cost to the Owner.
4. Maintain stone check dams until the Public Works Department and/or Engineer approves the surrounding vegetation establishment.

### 3.2 TEMPORARY GRAVEL CONSTRUCTION ENTRANCE

A. Purpose

1. The purpose of the temporary gravel construction entrance pad is to clean the tires of vehicles exiting the site and prevent or limit the amount of soils tracked off-site on the paved roads.

B. Construction

1. Verify location of temporary gravel construction entrance as shown on the drawings and determine if location will serve planned operations.
2. Size: 50' length minimum x 20' wide minimum. Contractor may need to increase size based upon volume of construction traffic and size of construction vehicles.
3. Provide turnout radii of 5' minimum, 20' preferred.
4. Strip topsoil and all vegetation. Excavate a minimum of 6" below existing paved roadway.
5. Proof roll subgrade. If subgrade is yielding, notify the Public Works Department and/or Engineer prior to additional excavation.
6. Install geotextile fabric prior to the placement of stone. Fabric should extend approximately 12" outside the edge of stone.
7. Place 6" minimum thickness of NCDOT Class A stone in excavated area.

C. Maintenance:

1. Maintain entrance pad for the remainder of the Contract time. If the stone becomes matted with soil material to the extent that the performance of the gravel construction entrance deteriorates, the contaminated stone shall be excavated, removed from the site to an approved location, and replaced with new stone at no cost to the Owner.
2. Any material that is tracked onto the roadway shall be removed immediately. Sweeping the tracked material into the road shoulder or ditch is not acceptable.

### 3.3 SILT FENCE

A. Construction

1. Steel posts shall be used. Wooden stakes are not acceptable.
2. Posts shall be 5' in height and be of the self-fastener angle type.
3. Post spacing shall be 8' on center when used with a wire mesh fencing and standard strength filter fabric.

4. Post spacing of 6' on center may be used without wire mesh fencing provided extra strength fabric is used.
5. Maximum fabric height is 24" above existing grade.
6. Wire mesh fence and fabric shall be installed on the upslope side of the fence.
7. Filter fabric and wire fence mesh shall be secured to the steel post utilizing plastic or wire ties no more than 12" apart. Plastic or wire ties shall have a minimum 50 pound tensile strength.
8. Lap all fabric joints 4' minimum.
9. Excavate a trench 4" wide x 8" deep along the upslope side of the fence and place 12" of fabric in the excavated area. Backfill the excavation with the soil placed over the filter fabric. Compact the soil.

B. Maintenance

1. Inspect silt fence immediately following all rainfall events.
2. Remove sediment build up along fence.
3. Repair and replace silt fence as necessary.
4. Maintain silt fence throughout the Contract time.

### 3.4 ROCK ENERGY DISSIPATER

- A. Excavate to the indicated depth of rock lining or nominal placement thickness as follows. Remove loose, unsuitable material below bottom of rock lining, then replace with suitable material. Thoroughly compact and finish entire foundation area to firm, even surface.
- B. Lay and overlay geotextile fabric over substrate. Lay fabric parallel to flow from upstream to downstream. Overlap edges upstream over downstream. Provide a minimum overlap of 3 feet. Offset adjacent roll ends a minimum of 5 feet when lapped. Cover fabric as soon as possible and in no case leave fabric exposed more than 1 week.
- C. Carefully place rock on geotextile fabric to produce an even distribution of pieces, minimize the number of voids, and prevent tearing of the fabric.
- D. Unless indicated otherwise, place full course thickness in one operation to prevent segregation and to avoid displacement of underlying material. Arrange individual rocks for uniform distribution.

### 3.5 BLOCK AND GRAVEL DROP INLET PROTECTION

A. Construction:

1. Construct block and gravel drop inlet protection in accordance with drawings and details.
2. Lay 2 rows of 8" hollow CMU's in a running bond around the drop inlet.
3. Lower edge of CMU shall be 1-2" below the top of the grate frame to prevent lateral slippage of the blocks towards the center of the drop inlet.
4. Two 8" CMUs on the first course shall be laid on their side to allow the passage of water.

5. Fit hardware cloth with 1/2" opening over the sideways laid CMUs to retain stone. Edges of hardware cloth shall extend 6" past edges of sideways laid CMUs in all directions.
6. Place clean NCDOT #5 or #57 stone around the outside of the CMUs to a height of 12-14" and slope away from the drop inlet at a 2:1 slope on all sides.

B. Maintenance:

1. Inspect drop inlets immediately following all rainfall events.
2. Remove sediment buildup around the stone.
3. If the stone becomes matted with soil material to the extent that the drainage through the stone deteriorates, the contaminated stone shall be removed from the site to an approved location and replaced with new stone at no cost to the Owner.
4. Maintain drop inlet protection until final paving or until the Public Works Department and/or Engineer approves the surrounding vegetation establishment.

### 3.6 ROCK PIPE INLET PROTECTION

A. Construction:

1. Clear the area of all debris that might hinder excavation and disposal of spoil.
2. Install the Class B or Class I riprap in a semi-circle around the pipe inlet. The stone should be built up higher on each end where it ties into the embankment. The minimum crest width of the riprap should be 3 feet, with a minimum bottom width of 11 feet. The minimum height should be 2 feet, but also 1 foot lower than the shoulder of the embankment or diversions.
3. A 1 foot thick layer of NC DOT #5 or #57 stone should be placed on the outside slope of the riprap.
4. The sediment storage area should be excavated around the outside of the stone horseshoe 18 inches below natural grade.
5. When the contributing drainage area has been stabilized, fill depression and establish final grading elevations, compact area properly, and stabilize with ground cover.

B. Maintenance

1. Inspect rock pipe inlet protection at least weekly and after each significant (1/2 inch or greater) rainfall.
2. Remove sediment and restore the sediment storage area to its original dimensions when the sediment has accumulated to 1/2 the design depth of the trap.
3. Place the sediment that is removed in the designated disposal area and replace the contaminated part or the gravel facing.
4. Check the structure for damage. Any riprap displaced from the stone horseshoe must be replaced immediately.
5. After all the sediment-producing areas have been permanently stabilized, remove the structure and all the unstable sediment. Smooth the area to blend with the adjoining areas and provide permanent ground cover.

### 3.7 RIPRAP CHANNEL LINING

- A. Excavate ditches in accordance with Section 31 00 00 Earthwork and to the lines and grade on the drawings and details.
- B. Where ditch bottoms and side slopes are to be lined with riprap, over-excavate the ditch bottom and sides to receive the geotextile fabric and the riprap. Over-excavation shall be done such that the finished grade of the top of the riprap is 2 inches below the proposed invert of the ditch.
- C. Lay and overlay geotextile fabric over substrate. Lay fabric parallel to flow from upstream to downstream. Overlap edges upstream over downstream. Provide a minimum overlap of 3 feet. Offset adjacent roll ends a minimum of 5 feet when lapped. Cover fabric as soon as possible and in no case leave fabric exposed more than 1 week.
- D. Carefully place rock on geotextile fabric to produce an even distribution of pieces, minimize the number of voids, and prevent tearing of the fabric.
- E. Unless indicated otherwise, place full course thickness in one operation to prevent segregation and to avoid displacement of underlying material. Arrange individual rocks for uniform distribution.

### 3.8 SITE STABILIZATION

- A. Incorporate erosion control devices indicated on the Drawings into the Project at the earliest practicable time.
- B. Construct, stabilize, and activate erosion controls before site disturbance within tributary areas of those controls.
- C. Stockpile and waste pile heights shall not exceed 15 feet. Slope stockpile sides at 2:1 or flatter. Cover to prevent windblown dust.
- D. Stabilize any disturbed area of affected erosion control devices on which activity has ceased and which will remain exposed for more than 20 days.
  - 1. During non-germinating periods, apply mulch at recommended rates.
  - 2. Stabilize disturbed areas which are either at finished grade or will not be disturbed within one year in accordance with Section 32 92 19 Seeding.
- E. Stabilize ditch excavations and stockpiles immediately.

### 3.9 FIELD QUALITY CONTROL

- A. Inspect erosion control devices on a weekly basis and after each runoff event. Make necessary repairs to ensure erosion and sediment controls are in good working order.

### 3.10 CLEANING

- A. When sediment accumulation in sedimentation structures has reached one-third depth of sediment structure or device, remove and dispose of sediment.
- B. Final inspection of the storm water detention pond will require removal of all accumulated sediment from the forebay and main basin prior to final acceptance. Depth of both shall be returned to design inverts.
- C. Do not damage structure or device during cleaning operations.
- D. Do not permit sediment to erode into construction areas, site areas, or natural waterways.

END OF SECTION

## SECTION 31 37 00

### RIPRAP

#### PART 1 GENERAL

##### 1.1 RELATED DOCUMENTS

- A. The Proposal-Agreement Section of the Contract and other sections of this Division apply to the work in this Section.
- B. North Carolina Erosion and Sediment Control Planning and Design Manual.

##### 1.2 SUMMARY

- A. Section Includes:
  - 1. Riprap placed loosely.

##### 1.3 MEASUREMENT AND PAYMENT

- A. Riprap:
  - 1. Basis of Measurement: By the Ton of riprap installed. If riprap is part of Rock Energy Dissipater or Riprap Channel Lining, refer to Measurement and Payment Section of 31 25 13 – Erosion Controls.
  - 2. Basis of Payment: Includes supplying and placing riprap to the lines, thicknesses and elevations as shown on the drawings.

##### 1.4 SUBMITTALS

- A. Data from material supplier indicating compliance of material to NCDOT standards for the Types and Classes of riprap to be provided.

##### 1.5 QUALITY ASSURANCE

- A. Furnish each aggregate material from single source throughout the Work.
- B. Perform work in accordance with and provide materials in accordance with North Carolina Department of Transportation Standard Specifications for Roads and Structures, latest edition.

#### PART 2 PRODUCTS

##### 2.1 MATERIALS

- A. Furnish materials in accordance with North Carolina Department of Transportation Standard Specifications for Roads and Structures, latest edition.

- B. Riprap: Granite type; irregular shaped rock; solid and non-friable. Class of stone needed is specified on drawings and in detail drawings.
- C. Binder: Portland cement.
- D. Geotextile Fabric: Specified on drawings and in detail drawings.

### PART 3 EXECUTION

#### 3.1 PLACEMENT

- A. Place geotextile fabric over substrate; lap edges and ends.
- B. Place riprap at culvert pipe ends, embankment slopes, and channel linings as indicated on the Drawings.
- C. Installed Thickness: As indicated on the Drawings.

END OF SECTION

## SECTION 32 92 19

### SEEDING

#### PART 1 GENERAL

##### 1.1 RELATED DOCUMENTS

- A. The Proposal-Agreement Section of the Contract and other sections of this Division apply to the work in this Section.
- B. North Carolina Erosions and Sediment Control Planning and Design Manual.

##### 1.2 SUMMARY

- A. Section Includes:
  - 1. Fertilizing
  - 2. Seeding
  - 3. Hydroseeding
  - 4. Mulching
  - 5. Maintenance

##### 1.3 MEASUREMENT AND PAYMENT

- A. Grassed Areas:
  - 1. Basis of Measurement: Per Acre of disturbed area to be seeded, measured to the nearest one-quarter acre.
  - 2. Basis of Payment: Includes seeding, watering, mowing and maintenance until the end of Contract time.

##### 1.4 REFERENCES

- A. ASTM International:
  - 1. ASTM C602 - Standard Specification for Agricultural Liming Materials.

##### 1.5 DEFINITIONS

- A. Finished Grade: Elevation of finished surface of planting soil.
- B. Subgrade: Surface or elevation of subsoil remaining after excavation is complete or top surface of a fill or backfill before planting soil is placed.
- C. Subsoil: All soil beneath the topsoil layer of the soil profile, typified by the lack of organic matter and soil organisms.
- D. Surface Soil: Soil that is present at the top layer of the existing soil profile at the Project site. In undisturbed areas, the surface soil is typically topsoil, and in disturbed areas the surface soil is typically subsoil.



- E. Weeds: Vegetative species other than specified species to be established in given area.

## 1.6 SUBMITTALS

- A. Product Data: For all pesticides and herbicides used on this project, submit product label and manufacturer's application instructions.
- B. Certification of Grass Seed: Submit data from seed vendor for each seed monostand or mixture stating the botanical and common name, percentage by weight of each species and variety, and percentage of purity, germination and weed seed. Include the year of production and date of packaging.
- C. Product Certificates: From Manufacturer, for all fertilizers, limes, and other soil amendments.

## 1.7 QUALITY ASSURANCE

- A. Provide seed mixture in containers showing percentage of seed mix, germination percentage, inert matter percentage, weed percentage, year of production, net weight, date of packaging, and location of packaging.
- B. Perform work in accordance with North Carolina Department of Transportation Standard Specifications for Roads and Structures, latest edition.
- C. Submit the following test reports to the Owner for each soil type to be amended:
  - 1. Soil Analysis including:
    - a. pH factor.
    - b. Composition of soil.
    - c. Percentage of organic content.
    - d. Recommendation of type and quantity of additives required to establish satisfactory pH and bring the supply of nutrients to a satisfactory level for planting.
  - 2. Testing shall be conducted by a soil testing laboratory in compliance with USDA Handbook No. 60.
  - 3. Recommendations shall be reported in weight per 1000 sq. ft. or volume per cu. yd. for nitrogen, phosphorus, and potash nutrients.

## 1.8 DELIVERY, STORAGE, AND HANDLING

- A. Deliver grass seed mixture in sealed containers. Seed in damaged packaging is not acceptable.
- B. Deliver fertilizer in waterproof bags showing weight, chemical analysis, and name of manufacturer.
- C. Store seed, fertilizer, lime, and mulch in a manner which prevents wetting and deterioration.

## 1.9 PROJECT CONDITIONS

- A. Weather Limitations: Proceed with planting only when existing and forecasted weather conditions permit planting to be performed with beneficial and optimum results. Apply products during favorable weather conditions according to manufacturer's instructions.
- B. The contractor shall field check the location of utilities before any ground disturbance associated with seeding, fertilizing, liming or mulching. The contractor shall be responsible for all damage resulting from neglect or failure to comply with this requirement.
- C. Work shall only take place on-site under the direct supervision of a competent, experienced landscape foreman.

## 1.10 MAINTENANCE SERVICE

- A. Maintain seeded areas for 30 days from Date of Substantial Completion.

## PART 2 PRODUCTS

### 2.1 SEED MIXTURE

- A. Grass Seed: Provide seed conforming to all statutory requirements and all rules and regulations adopted by the North Carolina Board of Agriculture. Deliver to site in original containers, labeled to show that the requirements of the N.C. Seed Law are met.
- B. No seed will be accepted with a date of test more than 8 months prior to the date of sowing, excluding the month in which the test was completed.
- C. When a low percentage of germination causes the quality of the seed to fall below the minimum pure live seed specified, the contractor may elect to increase the rate of application sufficiently to obtain the minimum pure live seed content specified, provided that such an increase in the rate of application does not cause the quantity of noxious weed seed per area to exceed the quantity that would be allowable at the regular rate of application.
- D. Seed: Seed of grass species as follows, with not less than 95 percent germination. Not less than 85 percent pure seed, and not more than 0.5 percent weed seed:

#### 1. Permanent Seeding:

Seed	Quantity	Planting Season
Tall Fescue Blend	6 lbs /1000 SF	Sept 1 – Mar 31
Common Bermuda 'Sahara' (Cynodon dactylon 'Sahara')	3 lbs / 1000 SF	Apr 1 – Aug 31

- a. If lawn areas are initially seeded with a fescue blend, the contractor shall be required to overseed with Bermuda seed after April 1.
- b. Mix temporary seed with Bermuda seed to establish cover before Bermuda seed germinates.

2. Temporary Seeding:

Seed	Quantity	Planting Season
Perennial Rye Grass	5 lbs /1000 SF	Sept 1 – Mar 15
Brown Top Millet	2 lbs / 1000 SF	Mar 15 – Aug 31

2.2 ACCESSORIES

- A. Mulching Material: Dry oat, hay, or wheat straw that is free from weeds and foreign matter detrimental to plant life.
- B. Fertilizer: Commercial grade fertilizer recommended for grass; of proportion necessary to eliminate deficiencies of topsoil, as indicated in analysis.
- C. Lime: Ground dolomitic limestone, ASTM C602, Class T agricultural limestone containing a minimum 80 percent calcium carbonate equivalent. Minimum 99 percent passing through a No. 8 sieve and a minimum 75 percent passing through a No. 60 sieve.
- D. Water: Clean, fresh, and free of substances or matter capable of inhibiting vigorous growth of grass.
- E. Erosion Fabric: Jute matting, open weave.
- F. Herbicide: Round-Up by Monsanto or approved equal.
- G. Stakes: Softwood lumber, chisel pointed.
- H. String: Inorganic fiber.

PART 3 EXECUTION

3.1 EXAMINATION

- A. Verify prepared soil base is ready to receive the work of this Section.
- B. Do not place or mix soils or soil amendments in frozen, wet, or muddy conditions.
- C. Suspend soil spreading, grading, and tilling operations during periods of excessive soil moisture.

- D. Uniformly moisten any soil which is excessively dry or dusty to the extent of being unworkable.

### 3.2 FERTILIZING

- A. Apply lime at application rate as recommended by soil analysis or at 40 lbs per 1000 sq. ft.
- B. Apply fertilizer at application rate as recommended by soil analysis.
- C. Do not apply fertilizer at same time or with same machine used to apply seed.
- D. Mix fertilizer thoroughly into upper 3 inches of topsoil.
- E. Lightly water soil to aid in dissipation of fertilizer. Irrigate top level of soil uniformly.

### 3.3 SEEDING

- A. Seed at the rates in accordance with 32 92 19 Seeding Part 2.1 D.
- B. Do not seed areas in excess of that which can be mulched on same day.
- C. Do not sow immediately following rain, when ground is too dry, or when winds are over 12 mph.
- D. Immediately following seeding, apply mulch to thickness of 1/8 – 1/4 inches. Maintain clear of shrubs and trees.
- E. Apply water with fine spray immediately after each area has been mulched. Saturate to 2 inches of soil.

### 3.4 HYDROSEEDING

- A. Hydroseeding: Mix specified seed, fertilizer and fiber mulch in water, utilizing equipment specifically designed for hydroseeding operations. Continue mixing until uniformly blended into a homogeneous slurry suitable for hydraulic application.
- B. Paper mulch material is not allowed.
- C. Mix slurry with a nonasphaltic tackifier.
- D. Apply slurry uniformly to all areas to be seeded in a two-step process. Apply first slurry coat at a rate so that mulch is deposited at not less than 500 lbs per acre dry weight and the seed component is deposited at not less than the specified seed sowing rate.
- E. Apply slurry coat of fiber mulch at a rate of 1000 lbs per acre.
- F. After application, apply water with fine spray immediately after each area has been hydroseeded. Saturate to 2 inches of soil and maintain moisture levels 2 – 4 inches.

### 3.5 MAINTENANCE

#### A. General Care

1. Maintain and establish turf by watering, fertilizing, weeding, mowing, trimming, replanting, and performing other operations as required to establish healthy, viable turf.
2. Roll, regrade, and replant bare or eroded areas and remulch to produce a uniformly smooth turf. Provide materials and installation identical to those used in the original installation.
3. As necessary, fill in any soil subsidence that may occur because of settling or other processes. Replace materials and turf damaged or lost in areas of subsidence.
4. In areas where mulch has been disturbed by wind or maintenance operations, add new mulch and anchor as required to prevent displacement.
5. Apply treatments as required to keep turf and soil free of pests, pathogens, and disease. Use integrated pest management practices whenever possible to minimize the use of pesticides and reduce hazards.

#### B. Watering

1. Install and maintain temporary piping, hoses, and turf-watering equipment to convey water from sources and to keep turf uniformly moist to a depth of 4 inches.
2. Schedule watering to prevent wilting, puddling, erosion, and displacement of seed or mulch. Lay out temporary watering system to avoid walking over muddy or newly planted areas.
3. Water turf with fine spray at a minimum rate of one inch per week unless rainfall precipitation is adequate.

#### C. Mowing

1. Mow grass as soon as top growth is tall enough to cut. Continue mowing without cutting more than 1/3 of grass height. Do not cut more than 1/3 of grass blade at each mowing. Do not delay mowing until grass blades bend over and become matted. Do not mow when grass is wet. Maintain the following heights:
  - a. Bermuda: 1"
  - b. All other grasses: 2-1/2"

D. Apply herbicides to control growth of weeds. Remedy damage resulting from improper use of herbicides.

E. Immediately reseed areas showing bare spots.

F. Repair washouts or gullies.

### 3.6 ACCEPTABLE TURF CONDITIONS

A. Satisfactorily Seeded Turf: At end of maintenance period a healthy, uniform, close stand of grass should be established, free of weeds and surface irregularities, with coverage exceeding 90 percent over any 10 sq. ft. and bare spots not exceeding 5 by 5 inches.

3.7 CLEANUP

- A. Perform cleanup during the installation and upon completion of the work. Remove soil and debris created during seeding operation from paved areas.
- B. Remove from site all excess material, debris, and equipment.

END OF SECTION

## SECTION 33 05 23

## TRENCHLESS UTILITY INSTALLATION – JACK AND BORE

## PART 1 GENERAL

## 1.1 RELATED DOCUMENTS

- A. The Proposal-Agreement Section of the Contract and other sections of this Division apply to the work in this Section.

## 1.2 SUMMARY

- A. Section Includes:
  - 1. Excavation for approach trenches and pits.
  - 2. Casing pipe.
  - 3. Carrier pipe.

## 1.3 UNIT PRICE - MEASUREMENT AND PAYMENT

- A. Jacked Pipe:
  - 1. Basis of Measurement: By linear foot measured on invert of jacked pipe from face to face of jacked pipe.
  - 2. Basis of Payment: Includes excavation, jacked pipe, grout, accessories, tests, and backfill.

## 1.4 REFERENCES

- A. American Association of State Highway and Transportation Officials:
  - 1. AASHTO T180 - Standard Specification for Moisture-Density Relations of Soils Using a 4.54-kg (10-lb) Rammer and a 457-mm (18-in.) Drop.
- B. American Railway Engineering and Maintenance-of-Way Association:
  - 1. AREMA - Manual for Railway Engineering.
- C. ASTM International:
  - 1. ASTM A36/A36M - Standard Specification for Carbon Structural Steel.
  - 2. ASTM A53/A53M - Standard Specification for Pipe, Steel, Black and Hot-Dipped, Zinc-Coated, Welded and Seamless.
  - 3. ASTM A307 - Standard Specification for Carbon Steel Bolts and Studs, 60 000 PSI Tensile Strength.
  - 4. ASTM A449 - Standard Specification for Quenched and Tempered Steel Bolts and Studs.
  - 5. ASTM A1011/A1011M - Standard Specification for Steel, Sheet and Strip, Hot-Rolled, Carbon, Structural, High-Strength Low-Alloy and High-Strength Low-Alloy with Improved Formability.
  - 6. ASTM C33 - Standard Specification for Concrete Aggregates.
  - 7. ASTM C150 - Standard Specification for Portland Cement.

8. ASTM C404 - Standard Specification for Aggregates for Masonry Grout.
9. ASTM C443 - Standard Specification for Joints for Circular Concrete Sewer and Culvert Pipe, Using Rubber Gaskets.
10. ASTM D698 - Standard Test Method for Laboratory Compaction Characteristics of Soil Using Standard Effort (12,400 ft-lbf/ft<sup>3</sup> (600 kN-m/m<sup>3</sup>)).
11. ASTM D1557 - Standard Test Method for Laboratory Compaction Characteristics of Soil Using Modified Effort (6,000 ft-lbf/ft<sup>3</sup> (2,700 kN-m/m<sup>3</sup>)).
12. ASTM D2922 - Standard Test Method for Density of Soil and Soil-Aggregate in Place by Nuclear Methods (Shallow Depth).
13. ASTM D3017 - Standard Test Method for Water Content of Soil and Rock in Place by Nuclear Methods (Shallow Depth).

D. American Welding Society:

1. AWS D1.1 - Structural Welding Code - Steel.

E. National Utility Contractors Association:

1. NUCA - Pipe Jacking & Microtunneling Design Guide.
2. NUCA - Trenchless Excavation Construction Equipment & Methods Manual.

## 1.5 SUBMITTALS

- A. Product data for steel casing pipe and pipe supports.
- B. Project Record Documents: Record actual locations of casing, carrier pipe, and invert elevations.
- C. Identify and describe unexpected variations to subsoil conditions or discovery of uncharted utilities.

## 1.6 QUALITY ASSURANCE

- A. Perform work in accordance with NUCA Trenchless Excavation Construction Equipment & Methods Manual and NUCA Pipe Jacking & Microtunneling Design Guide.
- B. Perform work and provide materials in accordance with North Carolina Department of Transportation Standard Specifications for Roads and Structures, latest edition.

## 1.7 QUALIFICATIONS

- A. Use an adequate number of skilled workmen who are thoroughly trained and experienced in the necessary crafts and who are completely familiar with the specified requirements and the methods needed for proper performance of the work of this Section.
- B. Use a sufficient number of equipment of adequate size and capacity to accomplish the work in a timely manner.



## 1.8 DELIVERY, STORAGE, AND HANDLING

- A. Provide temporary end caps and closures on piping and fittings. Maintain in place until installation.
- B. Protect piping from entry of foreign materials and water by temporary covers, completing sections of work, and isolating parts of completed system.
- C. Accept system components on site in manufacturer's original containers or configuration. Inspect for damage.
- D. Use wooden shipping braces between layers of stacked pipe. Stack piping lengths no more than 3 layers high.
- E. Store field joint materials indoors in dry area in original shipping containers.
- F. Support casing and carrier pipes with nylon slings during handling.

## 1.9 FIELD MEASUREMENTS

- A. Verify invert elevations of existing work prior to excavation and installation of casing pipe.

## PART 2 PRODUCTS

### 2.1 CASING AND JACKING PIPE MATERIALS

- A. Steel Casing Pipe: All encasement pipe shall be smooth wall welded steel conforming to ASTM Designation A139, Grade B. The outside of the pipe shall be coated in accordance with AWWA Standard C203.

### 2.2 CARRIER PIPE MATERIALS

- A. Water Distribution: As specified in Section 33 11 00 Water Distribution.

### 2.3 ACCESSORIES

- A. Supports and Insulators:
  - 1. Spiders: Bituminous coated steel spiders.
- B. Steel Strapping: ASTM A36/A36M.
- C. Grout: 1 part Portland cement, 3 parts mortar sand, and water.

## PART 3 EXECUTION

### 3.1 PREPARATION

- A. Identify required lines, levels, contours, and datum locations.
- B. Locate, identify, and protect from damage any utilities indicated to remain.
- C. Notify utility company to remove and relocate utilities.
- D. Protect plant life, lawns and other features remaining as portion of final landscaping.
- E. Protect bench marks, survey control points, existing structures, fences, sidewalks, paving, and curbs from excavating equipment and vehicular traffic.
- F. Establish elevations of casing with not less than three feet of cover.

### 3.2 DEWATERING

- A. Intercept and divert surface drainage precipitation and groundwater away from excavation through use of dikes, curb walls, ditches, pipes, sumps, or other means.
- B. Develop substantially dry subgrade for prosecution of subsequent operations.

### 3.3 PITS OR APPROACH TRENCHES

- A. Excavate approach trenches or pits as site conditions require.
- B. Ensure casing entrance face as near perpendicular to alignment as conditions permit.
- C. Establish vertical entrance face at least 1 foot above top of casing.
- D. Install dewatering measures and excavation supports as specified in Section 31 23 17 Trenching and Backfilling.

### 3.4 CASING PIPE INSTALLATION

- A. Boring:
  - 1. Push pipe into ground with boring auger rotating within pipe to remove spoil. Do not advance cutting head ahead of casing pipe except for distance necessary to permit cutting teeth to cut clearance for pipe. Arrange machine bore and cutting head to be removable from within pipe. Arrange face of cutting head to provide barrier to free flow of soft material.
  - 2. When unstable soil is encountered during boring, retract cutting head into casing to permit balance between pushing pressure and ratio of pipe advancement to quantity of soil.
  - 3. When voids develop greater than outside diameter of pipe by approximately one inch, grout to fill voids.

4. When boring is obstructed, relocate, jack, or tunnel as directed by Public Works Department and/or Engineer.

B. Jacking

1. Construct adequate thrust wall normal to proposed line of thrust.
2. Impart thrust load to pipe through suitable thrust ring sufficiently rigid to ensure uniform distribution of thrust load on full pipe circumference.

3.5 PRESSURE GROUTING

- A. Pressure grout annular space between casing pipe and surrounding earth.

3.6 CARRIER PIPE INSTALLATION

- A. Clean, inspect, and handle pipe in accordance with Sections 33 11 00 Water Distribution.
- B. Pipeline Installation: After completion of the boring and encasement, insert the pipeline in pre-jointed segments. A galvanized steel spider shall be installed behind each carrier pipe bell in the encasement pipe, as shown on the drawings and details. There shall be a total of 3 spiders per joint of pipe.
- C. Place carrier pipe in accordance with Sections 33 11 00 Water. Exercise care to prevent damage to pipe joints when carrier pipe is placed in casing.
- D. Support pipeline within casing so no external loads are transmitted to carrier pipe. Attach supports to barrel of carrier pipe; do not rest carrier pipe on bells.
- E. Pressure test line prior to grouting ends of casing pipe.
- F. Tie end of casing to first fitting or valve with threaded rod. For pipe sizes 2" – 6" the threaded rod shall be welded to the top and bottom of the casing pipe. For pipe sizes 8" and larger, the threaded rod shall be welded at four locations equal distance around the circumference of the casing pipe. Threaded rod shall be welded the casing pipe no less than 18" from the end. Rod must be welded continuously on both sides.
- G. Grout ends of casing to seal.

3.7 TOLERANCES

- A. Do not over-cut excavation by more than 1 inch greater than outside diameter of casing pipe.
- B. Install casing pipe to vertical and horizontal alignment on drawings within plus or minus 3 inches prior to installation of carrier pipe.
- C. Install pipe bells with minimum 1/2 inch clearance to casing.

END OF SECTION

## SECTION 33 05 24

## HORIZONTAL DIRECTIONAL DRILLING

## PART 1 GENERAL

## 1.1 RELATED DOCUMENTS

- A. The Proposal-Agreement Section of the Contract and other sections of this Division apply to the work in this Section.

## 1.2 SUMMARY

- A. Section Includes:
  - 1. Excavation for approach trenches and pits.
  - 2. Horizontal directional drilling.
  - 3. Pipe.

## 1.3 MEASUREMENT AND PAYMENT

- A. Horizontal Directional Drilling:
  - 1. Basis of Measurement: By linear foot.
  - 2. Basis of Payment: Includes:
    - a. Excavation
    - b. Fusing
    - c. Drilling
    - d. Pipe
    - e. Accessories
    - f. HDPE Mechanical Joint Adapter
    - g. Backfilling
    - h. Testing.

## 1.4 REFERENCES

- A. American Association of State Highway and Transportation Officials:
  - 1. AASHTO T180 - Standard Specification for Moisture-Density Relations of Soils Using a 4.54-kg (10-lb) Rammer and a 457-mm (18-in.) Drop.
- B. ASTM International:
  - 1. ASTM D698 - Standard Test Method for Laboratory Compaction Characteristics of Soil Using Standard Effort (12,400 ft-lbf/ft<sup>3</sup>).
  - 2. ASTM D1557 - Standard Test Method for Laboratory Compaction Characteristics of Soil Using Modified Effort (6,000 ft-lbf/ft<sup>3</sup>).
  - 3. ASTM D2922 - Standard Test Method for Density of Soil and Soil-Aggregate in Place by Nuclear Methods (Shallow Depth).
  - 4. ASTM D3017 - Standard Test Method for Water Content of Soil and Rock in Place by Nuclear Methods (Shallow Depth).

5. ASTM F1962 - Standard Guide for Use of Maxi-Horizontal Directional Drilling for Placement of Polyethylene Pipe or Conduit Under Obstacles, Including River Crossings.

- C. National Utility Contractors Association:
1. NUCA - HDD Installation Guidelines.

- D. The Plastic Pipe Institute, Inc.:
1. PPI Generic Butt Fusion Joining Procedure TR-33.

## 1.5 DESIGN REQUIREMENTS

- A. Design Criteria:
1. Drilling Steering System: Remote with continuous electronic monitoring of boring depth and location.
  2. Directional Change Capability: 90 degree with 35 foot radius curve.
  3. Ratio of Reaming Diameter to Pipe Outside Diameter:
    - a. Nominal pipe diameter of 6 inches and smaller: 1.5 maximum.
    - b. Nominal pipe diameter larger than 6 inches: Submit recommended ratio and reaming procedures for review.

## 1.6 SUBMITTALS

- A. Shop Drawings:
1. Submit technical data for equipment, method of installation, and proposed sequence of construction.
  2. Include information pertaining to pits, dewatering, method of spoils removal, equipment size and capacity, equipment capabilities including installing pipe on radius, type of drill bit, drilling fluid, method of monitoring line and grade and detection of surface movement, name plate data for drilling equipment and mobile spoils removal unit.
- B. Product Data:
1. Identify source of water used for drilling.
  2. Submit copy of approvals and permits for use of water source.
- C. Project Record Documents: Record actual locations of pipe and invert elevations and provide bore logs.
- D. Identify and describe unexpected variations to subsoil conditions or discovery of uncharted utilities.
- E. Record actual depth of pipe at 25-foot intervals.
- F. Record actual horizontal location of installed pipe.
- G. Show depth and location of abandoned bores.
- H. Record depth and location of drill bits and drill stems not removed from bore.

## 1.7 QUALITY ASSURANCE

- A. Perform work in accordance with the following:
  - 1. NUCA HDD Installation Guidelines.
  - 2. ASTM F1962.

## 1.8 DELIVERY, STORAGE, AND HANDLING

- A. Provide temporary end caps and closures on piping and fittings until pipe is installed.
- B. Protect pipe from entry of foreign materials and water by temporary covers, completing sections of work, and isolating parts of completed system.
- C. Accept products on site in manufacturer's original containers or configuration. Inspect for damage.
- D. Use shipping braces between layers of stacked pipe. Stack piping lengths no more than 3 layers high.
- E. Support pipes with nylon slings during handling.

## PART 2 PRODUCTS

### 2.1 DRILLING FLUID

- A. Drilling Fluid: Liquid bentonite clay slurry; totally inert with no environmental risk.

### 2.2 PIPE

- A. Water Distribution System Pipe: HDPE SDR-9.

### 2.3 FILL MATERIALS

- A. On-site suitable material.

### 2.4 WATER SOURCE

- A. Water: Potable.

### 2.5 ACCESSORIES

- A. HDPE mechanical joint adapter meeting the requirements of AWWA C111/ANSI A21.11.
- B. Mechanical joint accessory kits
- C. Grout: 1 part Portland cement, 3 parts mortar sand, and water.

## PART 3 EXECUTION

### 3.1 PREPARATION

- A. Notification: The Public Works Department and/or Engineer should be notified at least forty-eight (48) hours prior to beginning the work of this Section.
- B. Call NC One Call service at 811 not less than three working days before performing Work.
  - 1. Request underground utilities to be located and marked within and surrounding construction areas.
- C. Locate, identify, and protect from damage any utilities indicated to remain.
- D. Identify required lines, levels, contours, and datum locations.
- E. Protect plant life, lawns, and other features remaining as portion of final landscaping.
- F. Protect benchmarks, survey control points, existing structures, fences, sidewalks, paving, and curbs from excavating equipment and vehicular traffic.

### 3.2 DEWATERING

- A. Intercept and divert surface drainage, precipitation, and groundwater away from excavation through use of dikes, curb walls, ditches, pipes, sumps or other means.
- B. Develop and maintain substantially dry subgrade during drilling and pipe installation.

### 3.3 EXCAVATION

- A. Excavate subsoil as specified in Section 31 23 17 Trenching and Backfilling.
- B. Excavate approach trenches and pits as site conditions require. Minimize number of access pits.
- C. Provide sump areas to contain drilling fluids.
- D. Restore areas after completion of drilling and carrier pipe installation.

### 3.4 DRILLING

- A. Drill pilot bore with vertical and horizontal alignment as indicated on drawings and details.
- B. Guide drill remotely from ground surface to maintain alignment by monitoring signals transmitted from drill bit.
  - 1. Monitor depth, pitch, and position.
  - 2. Adjust drill head orientation to maintain correct alignment.

- C. Inject drilling fluid into bore to stabilize hole, remove cuttings, and lubricate drill bit and pipe.
- D. Continuously monitor drilling fluid pumping rate, pressure, viscosity, and density while drilling pilot bore, back reaming, and installing pipe to ensure adequate removal of soil cuttings and stabilization of bore.
  - 1. Provide relief holes when required to relieve excess pressure.
  - 2. Minimize heaving during pullback.
- E. Calibrate and verify electronic monitor accuracy during first 50 feet of bore in presence of the Public Works Department and/or Engineer before proceeding with other drilling. Excavate minimum of four test pits spaced along first 50 feet bore to verify required accuracy. When required accuracy is not met, adjust equipment or provide new equipment capable of meeting required accuracy.
- F. After completing pilot bore, remove drill bit.

### 3.5 DRILLING OBSTRUCTIONS

- A. When obstructions are encountered during drilling, notify the Public Works Department and/or Engineer immediately. Do not proceed around obstruction without the Public Works Department and/or Engineer's approval.
- B. For conditions requiring more than 3 feet deviation in horizontal alignment, submit new shop drawings to the Public Works Department and/or Engineer for approval before resuming work.
- C. Maintain adjusted bore alignment within easement or right-of-way.

### 3.6 PIPE INSTALLATION

- A. Prior to pulling, pipe is to be air tested above ground to ensure all welds are complete and free of imperfections.
- B. After completing pilot bore, remove drill bit. Install reamer and pipe pulling head. Select reamer with minimum bore diameter required for pipe installation.
- C. Attach pipe to pipe pulling head. Pull reamer and pipe to entry pit along pilot bore.
- D. Inject drilling fluid through reamer to stabilize bore and lubricate pipe.
- E. Install piping with horizontal and vertical alignment as shown on drawings and details.
- F. Protect and support pipe being pulled into bore so pipe moves freely and is not damaged during installation.
- G. Do not exceed pipe manufacturer's recommended pullback forces.



- H. Install trace wire continuous with each bore. Splice trace wire only at intermediate bore pits. Tape or insulate trace wire to prevent corrosion and maintain integrity of pipe detection.
  - 1. Multiple trace wires are to be pulled with each pipe run.
  - 2. Terminate trace wire for each pipe run at structures along pipe system.
  - 3. Provide extra length of trace wire at each structure, so trace wire can be pulled 3 feet out top of structure for connection to detection equipment.
  - 4. Test trace wire for continuity for each bore before acceptance and re-bore if necessary.
- I. Provide sufficient length of pipe to extend past termination point to allow connection to other pipe sections.
- J. Slip the gland ring over the pipe end and then butt fuse the HDPE MJ adapter to the end of the pipe using the PPI generic Butt Fusion Joining Procedure TR-33.
- K. Prior to making connections the pipe shall be air tested to ensure the structure integrity of the pipe was not compromised during the pull.
- L. Mark location and depth of bore with spray paint on paved surfaces, and wooden stakes on non-paved surfaces at 25-foot intervals.
- M. Fiberglass markers shall be used to mark pipe location when drilling through wetland areas. Markers shall be placed 10' feet from flow channels and at 50' intervals for the remaining length of pipe. BLUE markers shall be used for water and GREEN markers for sewer force mains. Markers shall be Pro-Mark PM-301.

### 3.7 SLURRY REMOVAL AND DISPOSAL

- A. Contain excess drilling fluids at entry and exit points until recycled or removed from site. Provide recovery system to remove drilling spoils from access pits.
- B. Remove, transport and legally dispose of drilling spoils.
  - 1. Do not discharge drilling spoils in sanitary sewers, storm sewers, or other drainage systems.
  - 2. When drilling in suspected contaminated soil, test drilling fluid for contamination before disposal.
- C. When drilling fluid leaks to surface, immediately contain leak and barricade area from vehicular and pedestrian travel before resuming drilling operations.
- D. Complete cleanup of drilling fluid at end of each work day.

### 3.8 ERECTION TOLERANCES

- A. Maximum Variation From Horizontal Position: 12 inches.
- B. Maximum Variation From Vertical Elevation: 2 inches.
- C. Minimum Horizontal and Vertical Clearance From Other Utilities: 12 inches.

D. When pipe installation deviates beyond specified tolerances, abandon bore, remove installed pipe, re-bore, and reinstall pipe in correct alignment.

E. Fill abandoned bores greater than 3” in diameter with grout or flowable fill material.

3.9 FIELD QUALITY CONTROL

A. Upon completion of pipe installation, test pipe in accordance with the following:

1. Water Distribution Pipe Testing: Section 33 11 00 Water Distribution.

3.10 CLEANING

A. Upon completion of drilling and pipe installation, remove drilling spoils, debris, and unacceptable material from approach trenches and pits. Clean up excess slurry from ground.

B. Restore approach trenches and pits to original condition.

END OF SECTION

## SECTION 33 11 00

## WATER UTILITY DISTRIBUTION

## PART 1 GENERAL

## 1.1 RELATED DOCUMENTS

- A. The Proposal-Agreement Section of the Contract and other sections of this Division apply to the work in this Section.

## 1.2 SUMMARY

- A. Section Includes:
  - 1. Pipe and fittings for public line, including potable water line and fire water line.
  - 2. Tapping sleeves and valves.
  - 3. Valves and fire hydrants.
  - 4. Underground pipe markers.

## 1.3 DEFINITIONS

- A. Off-Site Select Borrow: Approved soil material obtained off-site when specified or when sufficient approved soil material is not available from excavations.
- B. Unsuitable Soil: Soil produced from excavation of drainage features, cut to sub-grade, or required stripping that does not meet the definition and requirements of suitable soil.
- C. Suitable Soil: Soil produced from excavation of drainage features, cut to sub-grade, or required stripping that meets the definition and requirements of suitable soil.
- D. Topsoil: Soil produced from stripping the top or upper 4-8" soil layer from areas to be further excavated, re-landscaped, or re-graded without contamination from the subsoil. Stripping of topsoil is not required where excavation width is less than 10' or for the installation of pipe utilities. Topsoil shall be stockpiled on site at designation location for further use. Topsoil shall not be removed from site.
- E. Base Course: The layer placed between the sub-grade and surface pavement in a paving system.
- F. Excavation: Removal of material encountered above sub-grade elevations and to the lines and dimensions indicated.
- G. Porous Fill: Fill material supporting the slab on grade that also minimizes upward capillary flow of water.
- H. Structures: Buildings, slabs, curbs, utility appurtenances, tanks, retaining walls or other man-made stationary features constructed above or below ground surface.

- I. Sub-grade: The uppermost surface of an excavation or the top surface of a fill or backfill immediately below topsoil materials.
- J. Unauthorized excavation: Removal of materials beyond indicated sub-grade elevations or dimensions without direction by the Public Works Department and/or Engineer. Unauthorized excavation, as well as remedial work directed by the Public Works Department and/or Engineer, shall be at the Contractor's expense.
- K. Undercut excavation: Excavation below sub-grade elevations or beyond indicated lines and dimensions as directed by the Public Works Department and/or Engineer. Authorized undercut excavation and replacement material will be paid for according to Contract unit price for UNDERCUT and BACKFILL.
- L. Utilities: On-site underground pipes, conduits, ducts and cables.

#### 1.4 MEASUREMENT AND PAYMENT

- A. Pipe and Fittings:
  - 1. Basis of Measurement: By the Linear Foot. The length of water lines to be paid for will be determined by measuring along the centerlines of the various sizes of pipe furnished and installed. Pipe will be measured from center of fitting to center of fitting, from the center of the water distribution line to end of service connection and from center of water distribution line to center of hydrant.
  - 2. Basis of Payment includes:
    - a. Excavation for piping and all fittings, including all valves, sleeves, hydrants and blow-offs.
    - b. Removal of unsuitable soil material.
    - c. Piping and fittings, with the exception of valves, tapping sleeves and tapping valves, and fire hydrants.
    - d. Concrete thrust restraints.
    - e. Connection to public utility water source.
    - f. Backfilling with suitable trench excavation or on-site suitable soil.
    - g. Testing.
- B. Valves:
  - 1. Basis of Measurement: Per Each unit installed.
  - 2. Basis of Payment includes:
    - a. Valve
    - b. Accessories and kits
    - c. Valve Box
    - d. Concrete Collar as required
    - e. Blocking
    - f. Backfilling
- C. Tapping Sleeve, Tapping Valve and Tapping Saddle
  - 1. Basis of Measurement: Per Each unit installed.
  - 2. Basis of Payment includes:
    - a. Tapping sleeve and tap valve
    - b. Testing of assembly before wet tap

- c. Cutting the wet tap
  - d. Blocking
  - e. Backfilling
- D. Fire Hydrant
- 1. Basis of Measurement: Per Each unit installed.
  - 2. Basis of Payment includes:
    - a. Fire hydrant
    - b. Blocking and rodding
    - c. Drainage aggregate
    - d. Backfilling
- E. Blow Off
- 1. Basis of Measurement: Per Each unit installed.
  - 2. Basis of Payment includes:
    - a. Complete blow off assembly per drawings and details
    - b. Blocking
    - c. Backfilling
- F. Backflow Preventer
- 1. Basis of Measurement: Per Each unit installed.
  - 2. Basis of Payment includes:
    - a. Complete backflow preventer assembly
    - b. Accessories
    - c. Enclosure
    - d. Blocking backfilling
    - e. Testing

## 1.5 REFERENCES

- A. American Association of State Highway and Transportation Officials:
- 1. AASHTO T180 - Standard Specification for Moisture-Density Relations of Soils Using a 4.54-kg (10-lb) Rammer and a 457-mm (18-in.) Drop.
- B. American Society of Mechanical Engineers:
- 1. ASME B16.1 - Cast Iron Pipe Flanges and Flanged Fittings.
- C. ASTM International:
- 1. ASTM A36/A36M - Standard Specification for Carbon Structural Steel.
  - 2. ASTM A123/A123M - Standard Specification for Zinc (Hot-Dip Galvanized) Coatings on Iron and Steel Products.
  - 3. ASTM A307 - Standard Specification for Carbon Steel Bolts and Studs, 60 000 PSI Tensile Strength.
  - 4. ASTM D698 - Standard Test Method for Laboratory Compaction Characteristics of Soil Using Standard Effort (12,400 ft-lbf/ft<sup>3</sup> (600 kN-m/m<sup>3</sup>)).
  - 5. ASTM D1557 - Standard Test Method for Laboratory Compaction Characteristics of Soil Using Modified Effort (6,000 ft-lbf/ft<sup>3</sup> (2,700 kN-m/m<sup>3</sup>)).
  - 6. ASTM D1784 - Standard Specification for Rigid Poly (Vinyl Chloride) (PVC) Compounds and Chlorinated Poly (Vinyl Chloride) (CPVC) Compounds.

7. ASTM D2241 - Standard Specification for Poly (Vinyl Chloride) (PVC) Pressure-Rated Pipe (SDR Series).
8. ASTM D2922 - Standard Test Method for Density of Soil and Soil-Aggregate in Place by Nuclear Methods (Shallow Depth).
9. ASTM D3017 - Standard Test Method for Water Content of Soil and Rock in Place by Nuclear Methods (Shallow Depth).
10. ASTM D3139 - Standard Specification for Joints for Plastic Pressure Pipes Using Flexible Elastomeric Seals.
11. ASTM F477 - Standard Specification for Elastomeric Seals (Gaskets) for Joining Plastic Pipe.

D. American Water Works Association:

1. AWWA C104 - ANSI Standard for Cement Mortar Lining for Ductile-Iron Pipe and Fittings for Water.
2. AWWA C110 - ANSI Standard for Ductile-Iron and Gray-Iron Fittings, 3 In. Through 48 In. (76 mm Through 1,219 mm), for Water.
3. AWWA C111 - ANSI Standard for Rubber-Gasket Joints for Ductile-Iron Pressure Pipe and Fittings.
4. AWWA C115 - ANSI Standard for Flanged Ductile-Iron Pipe with Ductile-Iron or Gray-Iron Threaded Flanges.
5. AWWA C151 - ANSI Standard for Ductile-Iron Pipe, Centrifugally Cast, for Water or Other Liquids.
6. AWWA C153 - ANSI Standard for Ductile-Iron Compact Fittings for Water Service.
7. AWWA C200 - Steel Water Pipe 6 In. (150 mm) and Larger.
8. AWWA C203 - Coal-Tar Protective Coatings and Linings for Steel Water Pipelines - Enamel and Tape - Hot Applied.
9. AWWA C205 - Cement-Mortar Protective Lining and Coating for Steel Water Pipe - 4 In. and Larger - Shop Applied.
10. AWWA C206 - Field Welding of Steel Water Pipe.
11. AWWA C207 - Steel Pipe Flanges for Waterworks Service - Sizes 4 In. Through 144 In. (100 mm Through 3,600 mm).
12. AWWA C208 - Dimensions for Fabricated Steel Water Pipe Fittings.
13. AWWA C213 - Fusion-Bonded Epoxy Coating for the Interior and Exterior of Steel Water Pipelines.
14. AWWA C300 - Reinforced Concrete Pressure Pipe, Steel-Cylinder Type.
15. AWWA C301 - Prestressed Concrete Pressure Pipe, Steel-Cylinder Type.
16. AWWA C500 - Gate Valves for Water and Sewage Systems.
17. AWWA C600 - Installation of Ductile-Iron Water Mains and Their Appurtenances.
18. AWWA C605 - Water Treatment - Underground Installation of Polyvinyl Chloride PVC Pressure Pipe and Fittings for Water.
19. AWWA C606 - Grooved and Shouldered Joints.
20. AWWA C700 - Cold-Water Meters - Displacement Type, Bronze Main Case.
21. AWWA C701 - Cold-Water Meters - Turbine Type, for Customer Service.
22. AWWA C702 - Cold-Water Meters - Compound Type.
23. AWWA C706 - Direct-Reading, Remote-Registration Systems for Cold-Water Meters.

24. AWWA C900 - Polyvinyl Chloride (PVC) Pressure Pipe, and Fabricated Fittings, 4 In. through 12 In. (100 mm Through 300 mm), for Water Distribution.
  25. AWWA C905 - Polyvinyl Chloride (PVC) Pressure Pipe and Fabricated Fittings, 14 In. Through 36 In. (350 mm Through 1,200 mm), for Water Transmission and Distribution.
  26. AWWA M6 - Water Meters - Selection, Installation, Testing, and Maintenance.
- E. Manufacturer's Standardization Society of the Valve and Fittings Industry:
1. MSS SP-60 - Connecting Flange Joint between Tapping Sleeves and Tapping Valves.
- F. National Fire Protection Agency:
1. NFPA 24 - Standard for the Installation of Private Fire Service Mains and Their Appurtenances.

## 1.6 SUBMITTALS

- A. Product Data: Submit data on all pipe materials, pipe fittings, valves and accessories.
- B. Manufacturer's Installation Instructions: Submit special procedures required to install Products specified.
- C. Manufacturer's Certificate: Certify that products meet or exceed specifications.
- D. Record Documents (As-Built Drawings): Record location and depth of cover for pipe runs, valves, tees, and other fittings. Identify and describe variations to drawings and discovery of unidentified buried objects. Provide color photographs for all tee and valve connections and fire hydrant assemblies taken prior to placing any backfill. Photographs shall be numbered and keyed to the appropriate location on the as-built drawings.

## 1.7 QUALITY ASSURANCE

- A. All work shall conform to applicable AWWA and ASTM standards as the manufacturer's recommendations and instructions.

## 1.8 INSTALLER QUALIFICATIONS

- A. Installer shall be a licensed underground utility contractor licensed for such work in the State of North Carolina. Installing contractor's license status shall be current.

## 1.9 DELIVERY, STORAGE, AND HANDLING

- A. All pipe, of whatever material, shall be transported, handled, stored, and installed in strict compliance with applicable AWWA and ASTM standards as well as the manufacturer's instructions and recommendations.
- B. Deliver and store valves in shipping containers with labeling in place.
- C. Block individual and stockpiled pipe lengths to prevent moving.

- D. Do not place pipe or pipe materials on private property or in areas obstructing pedestrian or vehicle traffic.
- E. Store polyethylene materials out of sunlight.

## 1.10 FIELD MEASUREMENTS

- A. Verify field measurements prior to fabrication.

## PART 2 PRODUCTS

### 2.1 WATER PIPING

- A. Ductile Iron Pipe: AWWA C151. Bituminous outside coating: AWWA C151. Pipe Mortar Lining: AWWA C104, double thickness. Polyethylene Encasement: AWWA C105.
  - 1. Ductile cast iron pipe shall be Grade 60-42-10 centrifugally cast in accordance with ANSI Standard A21.51 (AWWA C151), latest revision for 200 psi operating pressures plus surge allowance of 100 psi. Wall thickness and strength shall conform to ANSI Standard A21.50 for cover as shown on the drawings and details. Each pipe shall be hydrostatically tested, before shipment, to a minimum of 500 psi. Factory tests and basis for acceptance shall be as specified in ANSI Standard A21.51. Unless otherwise specified, thickness class shall conform to ANSI A21.51 (AWWA C151).
    - a. Bells for push-on joints shall conform to the requirements of ANSI Standard A21.51, such as “Fastite,” “Tyton”, “Bell-Tite”, or equal. Pipe shall be nominal 18’ lengths. Joint detail, including rubber gaskets, shall conform to ANSI Standard Specification A21.11., AWWA C111, latest revision.
    - b. The pipe shall have an outside pipe coating of bituminous material in accordance with AWWA C151, latest revision. The final coat shall be continuous and smooth, being neither brittle when subjected to low temperatures nor sticky when exposed to hot sun. The coating shall be strongly adherent to the pipe at all temperatures.
    - c. Pipe 4”-12” shall have a minimum wall thickness equal to or greater than that of pressure class 350, 12”-20” shall have a minimum wall thickness equal to or greater than that of pressure class 300, and 24” pipe shall have a minimum wall thickness equal to or greater than that of pressure class 250. Pipe 6” and larger shall be Class 50. 4” diameter pipe shall be Class 51 or 52.
  - 2. Fittings for ductile iron pipe sizes 4”-12” shall be cast from ductile iron in accordance with ANSI/AWWA C153/A21.53.
    - a. All fittings shall be Class 350 ductile iron fittings, mechanical joint. Mechanical joints shall conform to ANSI/AWWA A21.11/C111. Wall and socket thicknesses shall be equal to Class 54 ductile iron pipe as specified in ANSI/AWWA A21.51/C151. Ductile iron shall be in accordance with ASTM A563 with minimum physical qualities of 70,000 psi tensile strength, 50,000 psi yield strength, and 5% elongation.



- b. All ductile cast iron fittings shall have cement mortar lining conforming to ANSI Standard A21.4, latest edition. Buried fittings shall be given a full coat inside and outside of a bituminous coating which conforms to ANSI 21.4, latest revision.
  3. Mechanical jointing ductile iron pipe shall be used only at the specific locations indicated on the drawings and details or as approved by the the Public Works Department and/or Engineer. The mechanical joint shall consist of:
    - a. a bell cast integrally with the pipe or fitting and provided with an exterior flange having cored or drilled bolt holes and interior annular recesses for the sealing gasket and the spigot of the pipe or fitting;
    - b. a pipe or fitting spigot;
    - c. a sealing gasket;
    - d. a separate cast iron follower gland having cored or drilled bolt holes; and (5) tee head bolts and hexagon nuts. The joint shall be designed to permit normal expansion, contraction and deflection of the pipe or fitting while maintaining a leak proof joint connection. The mechanical joint shall conform to the requirements of ANSI Standard Specification A21.11 and AWWA C111 Specifications, latest revision.
  4. Ductile iron flanged pipe shall be supplied in accordance with ANSI/AWWA C115/A21.15. Pipe barrels and flanges shall have a taper pipe thread (NPT) in accordance with B1.20.1, with thread diameters adapted to ductile iron pipe standard outside diameters. Ductile iron pipe used for flanging shall be centrifugally cast in metal molds and shall meet the requirements of ANSI/AWWA C151/A21.51. Flanges shall conform to ANSI/AWWA C110/A21.10. Flanged pipe shall be furnished in maximum length of 17'6" for sizes 4-48". The flanges shall conform to the drilling and facing requirements of ANSI B16.1 Class 125 flanges. Face to face dimensions shall conform to a tolerance of  $\pm 0.12$ " for sizes 3-64". The minimum class thickness for ductile iron flanged pipe to be threaded is class 53.
- B. Polyvinyl Chloride (PVC): AWWA C900 DR 18 Class 150 (pipe 4" – 12") and AWWA C905, DR 18 Class 150 (pipe larger than 12").
  1. Fittings for PVC pipe sizes " and larger shall be cast from ductile iron in accordance with ANSI/AWWA C153/A21.53.
  2. Ductile iron fittings shall have a working pressure rating of 350 psi for fitting sizes 12" and less. Fitting over 12" shall have a minimum rated working pressure of 250 psi. Mechanical joints shall conform to ANSI/AWWA A21.11/C111. Wall and socket thicknesses shall be equal to Class 54 ductile iron pipe as specified in ANSI/AWWA A21.51/C151. Ductile iron shall be in accordance with ASTM A563 with minimum physical qualities of 70,000 psi tensile strength, 50,000 psi yield strength, and 5% elongation.
    - a. All ductile cast iron fittings shall have cement mortar lining conforming to ANSI Standard A21.4, latest edition. Buried fittings shall be given a full coat inside and outside of a bituminous coating which conforms to ANSI 21.4, latest revision.
    - b. Appropriate transition gaskets shall be utilized for the SDR or class of PVC pipe.
  3. The pipe shall be furnished in nominal lengths of 20'.

- C. Polyvinyl Chloride (PVC): PVC pipe of 3" nominal diameter and less shall conform to ASTM Specification D-2241, "Standard Specification for Polyvinyl Chloride (PVC) Plastic Pipe (SDR-PR)", as it applies to Class 12454 (A or B) polyvinyl chloride plastic pipe, SDR 21 water pressure ratings of 200 psi at 23 C (73.4 F), with minimum physical requirements as listed in the following table.

NOMINAL SIZE INCHES	OUTSIDE DIAMETER INCHES	MIN. WALL THICKNESS INCHES	WEIGHT/ MO FT. POUNDS	WORKING PRESSURE PSI
¾	1.0501	0.060	11.8	200
1	1.315	0.063	15.9	200
1-1/4	1.660	0.079	24.8	200
1-1/2	1.900	0.090	32.2	200
2	2.375	0.113	50.8	200
2-1/2	2.875	0.137	74.2	200
3	3.500	0.167	110.0	200

1. Fittings for PVC ¾" – 2" shall be brass compression X MIP fittings. Solvent weld (glue) fittings will not be accepted.

- D. Pipe with nominal diameters of 4" and larger shall conform to ASTM Specification D-2241, "Standard Specification for Polyvinyl Chloride (PVC) Plastic Pipe (SDR-PR)," as it applies to Class 12454 (A or B) polyvinyl chloride plastic pipe, SDR 21 water pressure ratings of 200 psi at 23°C (73.4°F).

## 2.2 TAPPING SLEEVES, VALVES & SADDLES

- A. Tapping Sleeves: Furnish and install tapping sleeve and valve at the location(s) shown on the Contract Drawings and as required herein. The tapping sleeve and valve shall be suitable for wet installation without interrupting water service in any manner. The tapping sleeve and valve shall be installed in accordance with the manufacturer's recommendations and as shown on the drawings.
1. The tapping sleeve shall be fully gasketed wrap around tapping sleeve. The sleeve body shall be 18-8 stainless steel. The bolts and nuts shall be 18-8 stainless steel. The gasket shall be gridded virgin GPR compounded for water service. ASTM D2000-80M 4AA607. The outlet gasket is a Buna-N. The flange shall be ductile iron. The tapping sleeve shall be fitted with a female ¾" NPT and supplied with a ¾" plug with square head.
- B. Tapping Valves:
1. Tapping valves shall be "O" ring type with mechanical joint and conforming to AWWA C500-80 non-rising stem construction. Inlet flange end shall be Class 125 (ASA B16.1). The valves shall be as specified under section 2.3 of this specification for gate valves.

- C. Service Saddles: Furnish and install service saddle at location(s) shown on the Contract Drawings and all other locations of service

## 2.3 VALVES AND FIRE HYDRANTS

- A. Gate Valves: All gate valves shall be resilient seated wedge type that fully comply with the requirements of the latest revision of AWWA Standard C-509. All gate valves shall open by turning in a counterclockwise direction. All operating nuts, hand wheels and chain wheels shall have the direction of opening cast on them.
1. Valves 2" and larger shall be iron body, bronze mounted, resilient seat type.
  2. All valves other than flanged end valves shall be of the non-rising stem type.
  3. All flanged gate valves for hand operation shall be of the OS&Y type with conventional packing for either wheel or chain operation, as shown on the drawings and details.
  4. Unless otherwise shown on the drawings or stated in the proposal, all gate valves 2"-12" shall be designed for a working pressure of 200 psi and shall be tested to a minimum pressure of 400 psi.
  5. All gate valves 14"-24" shall be designed for a working pressure of 150 psi and hydrostatically tested to a minimum pressure of 300 psi.  
All buried valves shall be provided with a 2-piece screw-type valve box.
  6. Gate valves shall be of the mechanical joint type unless otherwise indicated on the drawings and details.
  7. All gate valves shall be manufactured by the American-Darling Co., Mueller Co., M&H Valve, Dresser, Clow, Kennedy Valve Co., or equal.
- B. Butterfly Valves: Butterfly valves shall conform to AWWA C-504, latest revision.
1. All valves for buried service shall have cast iron bodies with integrally cast mechanical joint ends conforming to AWWA C-111, latest revision.
  2. Valves for above ground use shall be short bodied with flanges conforming to ANSI B16.1, latest revision.
  3. The valve discs shall be designed to rotate 90 degrees from full open to tight shut position and shall have adjustable mechanical stops to govern the rotation of the disc.
  4. The valve shall have a Buna-N or a Buna-S valve seats with bronze or stainless steel seating rings.
  5. The stuffing boxes shall be integrally cast with the valve body.
  6. The shaft bearings shall be of the self-lubricating sleeve type with thrust bearings to keep the valve disc centered.
  7. Valves shall be pressure class 200 unless otherwise specified on the drawings.
- C. Swing Check Valves:
1. Valves 2" to 12": Swing check valves shall conform to AWWA C 508, latest revision.
  2. Small swing check valves shall have iron bodies with NPT ends.
  3. The swing disc shall be internally weighted or spring loaded and constructed of composition or bronze with rubber seats.
  4. Valves shall be rated at 175 lb. service water pressure or 200 lb. WOG.

5. Valves for use in aboveground installations shall be flanged without side spring and lever or when position.
- D. Fire Hydrants: Fire hydrants shall be of the compression or gate type conforming to AWWA C-502, latest revision and shall be the Owner's standard which consists of American – Darling Mark 73
1. All hydrants shall have a bronze to bronze main valve assembly.
  2. The hydrant shall have two 2-1/2" hose nozzles with caps and one 4-1/2" steamer connection conforming to the Camden County Water System Standards.
  3. Threads on nozzles and caps and operating nuts shall conform to those adopted by the Owner as standard.
  4. Hydrants shall open by turning counterclockwise and shall be so marked.
  5. The hydrant main valve shall meet or exceed the flow requirements of AWWA C-502 and shall be at least 4-1/2" in diameter and the hydrant elbow shall be a 6" MJ end.
  6. Elbow shall have interior coated with minimum 4 mils thickness epoxy in accordance with AWWA C550.
  7. The hydrant barrel shall be of such length to provide a minimum of 3'6" of bury.
  8. All hydrants shall be traffic models with breakable safety sleeve stem coupling with SS stem coupling pins.
  9. The Contractor shall include in the base bid price for fire hydrants and accessories all hydrant barrel extensions necessary to set the pumper nozzle at the specified height at the location shown on the drawings and details.
  10. Hydrants shall be designed for a 300 psi test pressure and a 150 psi working pressure.
  11. All hydrants shall be factory primed and finish painted.
  12. Final color of the hydrant body shall be Rustoleum enamel or equal "Safety Red".

#### 2.4 BACKFLOW PREVENTERS

- A. All existing and proposed water services, dedicated fire and irrigation lines and private distribution systems must be provided with an approved backflow prevention assembly in accordance with the Camden County Code of Ordinances – Chapter 13 – Water and Sewers, Article IV – Cross Connection Control and the Rules Governing Public Water Systems as found in Title 15A, Subchapter 18C of the North Carolina Administrative Code.
- B. Approved backflow prevention assemblies shall be installed above ground. Assemblies may be installed inside of buildings as long as there are no unprotected taps between the main and the building.
- C. The backflow prevention assembly(s) must be readily accessible at all times. Readily accessible means that only a one piece cover must be removed for an outside installation to test or perform maintenance on the assembly.

- D. Backflow prevention assemblies must be installed, tested and maintained by persons that have an approved cross connection School. It is also required that all assemblies be tested at the time of installation and annually thereafter. All assemblies must also have the rubber parts changed every five years.

## 2.5 FIRE HYDRANT LOCATION MARKERS

- A. Contractor shall install at all hydrant locations a reflective hydrant marker, Stimpsonite, Model 88AB, two-way blue reflector in centerline of pavement perpendicular to hydrant location using e-bond epoxy adhesive 1240/1241 per manufacturer's specifications.
- B. Contractor shall install Eberl Iron Works 60", spring-loaded reflector pole with flag mounted to the base of hydrant or approved equal.

## 2.6 VALVE LOCATION MARKERS

- A. All valve locations and blow offs shall be marked with a concrete valve marker with a metal coin on top showing valve size, distance, and direction. Valve markers shall be required for hydrant valves not located directly in front of hydrant.

## 2.7 UNDERGROUND PIPE MARKERS

- A. Plastic Ribbon Tape: Acid- and alkali-resistant polyethylene film warning tape manufactured for marking and identifying underground utilities, 3 inches wide and 4 mils thick minimum, continuously inscribed with a description of the utility, with metallic core encased in a protective jacket for corrosion protection, detectable by metal detector when tape is buried up to 2'-6" deep. Tape shall be Alarmtape by Paul Potter Associates, Detectatape by Allen Systems, Inc., Terra Tape by Griffolyn Co., Inc., or approved equal.
- B. Color: Blue
- C. Text: "CAUTION – WATER LINE BURIED BELOW".
- D. Detectable Tracer Wire: At all locations where pressure piping is installed and at lateral locations, non-ferrous or ferrous materials, the contractor shall install a continuous length of #12 solid copper wire taped to top of pipe. Wire shall be looped up in valve boxes and included along services.

## 2.8 BEDDING AND COVER MATERIALS

- A. Bedding: NCDOT #57 or #67 stone.
  - 1. Install stone bedding only at the direction of the the Public Works Department and/or Engineer.
- B. Soil Backfill from Above Pipe to Finish Grade:
  - 1. For any trenches with water, sanitary, or storm sewer utilities that are not located under curb or paved areas, backfill using on-site suitable soil when available.

2. For any trenches with water, sanitary, or storm sewer utilities that are located under curb or paved areas, backfill using only approved off-site select borrow.

## 2.9 ACCESSORIES

- A. Anchorages:
  1. Concrete Reaction Backing: Portland cement concrete mix, 3000 psi.
    - a. Cement: ASTM C 150, Type I.
    - b. Fine Aggregate: ASTM C33, sand.
    - c. Coarse Aggregate: ASTM C33, crushed gravel.
    - d. Water: Potable.
- B. Steel rods, bolt, lugs and brackets: ASTM A36/A36M or ASTM A307 carbon steel.
- C. Protective Coating: Bituminous coating.

## PART 3 EXECUTION

### 3.1 EXAMINATION AND PREPARATION

- A. Verify existing utility water main size, location, and inverts are as indicated on drawings.
- B. Pre-Construction Site Photos: (Recommended Only – NOT required).
  1. Take photographs along centerline of proposed pipe trench; minimum one photograph for each 50 feet of pipe trench.
  2. Show mail boxes, curbing, lawns, driveways, signs, culverts, and other existing site features.
  3. Include project description, date taken and sequential number on back of each photograph.
- C. Cut pipe ends square, ream pipe and tube ends to full pipe diameter, remove burrs. Use only equipment specifically designed for pipe cutting. The use of chisels or hand saws will not be permitted. Grind edges smooth with beveled end for push-on connections.
- D. Remove scale and dirt on inside and outside before assembly.
- E. Prepare pipe connections to equipment with flanges or unions.

### 3.2 BEDDING

- A. Excavate pipe trench in accordance with Section 31 23 17 for Work of this Section. Hand trim excavation for accurate placement of pipe to elevations indicated on Drawings.
- B. Dewater excavations to maintain dry conditions and preserve final grades at bottom of excavation.
- C. Provide sheeting and shoring in accordance with Section 31 23 17.

### 3.3 INSTALLATION - PIPE

- A. Install pipe in accordance with AWWA C600.
- B. Handle and assemble pipe in accordance with manufacturer's instructions and as indicated on drawings.
- C. Steel Rods, Bolt, Lugs, and Brackets: Coat buried steel with one coat of coal tar coating before backfilling.
- D. Lateral Separation of Sewers and Water Mains. Water mains shall be laid at least 10 feet laterally from existing or proposed sewers, unless local conditions or barriers prevent a 10-foot lateral separation—in which case:
  - 1. The water main is laid in a separate trench, with the elevation of the bottom of the water main at least 18 inches above the top of the sewer; or
  - 2. The water main is laid in the same trench as the sewer with the water main located at one side on a bench of undisturbed earth, and with the elevation of the bottom of the water main at least 18 inches above the top of the sewer.
  - 3. Crossing a Water Main Over a Sewer. Whenever it is necessary for a water main to cross over a sewer, the water main shall be laid at such an elevation that the bottom of the water main is at least 24 inches above the top of the sewer, unless local conditions or barriers prevent an 24 inch vertical separation in which case both the water main and sewer shall be constructed of ferrous materials and with joints that are equivalent to water main standards for a distance of 10 feet on each side of the point of crossing.
  - 4. Crossing a Water Main Under a Sewer. Whenever it is necessary for a water main to cross under a sewer, both the water main and the sewer shall be constructed of ferrous materials and with joints equivalent to water main standards for a distance of 10 feet on each side of the point of crossing. A section of water main pipe shall be centered at the point of crossing.”
- E. Separation of Water Mains and Storm Drains:
  - 1. There shall be a minimum of 12” vertical separation between water mains and storm drain lines. The water main shall be covered with unopened bags of concrete mix. One bag shall be placed on the water main centered under the storm drain and one bag shall be placed on each side of the centered bag.
  - 2. There shall be a minimum of 24” horizontal separation between water mains and storm drain lines.
- F. Install ductile iron piping and fittings to AWWA C600.
- G. No more than 7 services are to be installed on 2” water piping. Loop all 2” water lines if possible.
- H. Torque applied to mechanical joint bolts shall be 75-90 ft/lb for joint sizes 4” to 24” in accordance with AWWA C600.
- I. Weld pipe in accordance with AWWA C206. Weld joints in accordance with AWWA C205.

- J. Flanged Joints: Not to be used in underground installations except within structures.
- K. Route pipe in straight line. Relay pipe that is out of alignment or grade.
- L. Install pipe with no high points. If unforeseen field conditions arise which necessitate high points, install air release valves as directed by the Public Works Department and/or Engineer.
- M. Install pipe to have bearing along entire length of pipe. Excavate bell holes to permit proper joint installation. Do not lay pipe in wet or frozen trench.
- N. Prevent foreign material from entering pipe during placement.
- O. Install pipe to allow for expansion and contraction without stressing pipe or joints.
- P. Install pipe using a pipe joint lubricant (soap) that meets the requirements of NSF 61.
- Q. Close pipe openings with watertight plugs during work stoppages.
- R. Establish elevations of buried piping with not less than 36 inches of cover. Measure depth of cover from final surface grade to top of pipe barrel.
- S. Install copper tracer wire on top of all lines and lateral lines terminating to each valve box and meter box. Wire must be secured to pipe with tape.
- T. All tracer wire is to be tested to ensure continuity.
- U. Install acid- and alkali-resistant polyethylene film warning tape continuous buried 12 inches below finish grade.

### 3.4 INSTALLATION - VALVES AND HYDRANTS

- A. Install valves in conjunction with pipe laying; set valves plumb.
- B. Install hydrants; provide support blocking and drainage gravel; do not block drain hole.
  1. Set hydrants plumb with pumper nozzle facing roadway; set hydrants with centerline of pumper nozzle 18 inches above finished grade and safety flange not more than 6 inches nor less than 2 inches above grade.
  2. After hydrostatic testing, flush hydrants and check for proper drainage.
  3. No fittings shall be used to raise hydrant other than barrel extensions recommended by the manufacturer.
- C. Install hydrant tee, valve and hydrant in line and perpendicular to water line unless otherwise directed by Camden County or Engineer.
- D. When hydrant is installed across a ditch with an invert greater than 18" below the edge of asphalt a culvert shall be installed. Culvert is to be dual walled, corrugated, smooth bore HDPE with a length of 10'. The culvert will be bedded in no less than 6 inches of #57 or #67 stone with stone being placed up to the spring line of the pipe. Culvert to be sized by



the engineer. Fill material shall be placed in accordance to Section 31 23 17 – Trenching and Backfilling of these specifications. Any culverts larger than 36 inches shall require a separate design by the engineer.

### 3.5 INSTALLATION - TAPPING SLEEVES AND VALVES

- A. Install tapping sleeves and valves in accordance with drawings and in accordance with manufacturer's instructions.

### 3.6 INSTALLATION – BACKFLOW PREVENTERS

- A. All backflow prevention shall be installed in accordance with the manufacturer's specifications.
- B. All backflow prevention assemblies are to contain a strainer.
- C. Backflow prevention assemblies shall be installed at a minimum height of 12 inches and a maximum height of 60 inches above the floor or ground. Assemblies shall also have a clear horizontal distance of 18 inches around the entire diameter of the device.
- D. All backflow prevention assemblies installed outside of buildings must be installed in an approved enclosure with the exception of residential lawn irrigation backflow prevention assemblies. All enclosures shall be insulated and shall meet the requirements of ASSE standard 1060.
- E. All enclosures for backflow prevention assemblies on water lines 4" and larger are to be of stainless steel construction. Contractor is to ensure proper sizing of enclosure to allow for full use of all valves and hardware.
- F. All enclosures for backflow prevention assemblies installed on fire suppression lines must be heated.
- G. Double check valves and double detector check valves may be installed vertically with approval from the water department.
- H. Reduced pressure backflow prevention assemblies shall be installed only horizontally.
- I. All backflow preventers are required to be tested by a certified backflow prevention assembly tester within ten days of installation.

### 3.7 THRUST RESTRAINT

- A. Provide valves, tees, bends, caps, and plugs with concrete thrust blocks. Wrap all fittings with 6 mil polyethylene sheets covering all bolts and hardware. Pour concrete thrust blocks against undisturbed earth. Poured concrete shall be ready mixed. Locate thrust blocks at each elbow or change of pipe direction to resist resultant force and so pipe and fitting joints will be accessible for repair.

- B. Install tie rods, clamps, set screw retainer glands, or restrained joints. Protect metal restrained joint components against corrosion by applying a bituminous coating, or by concrete mortar encasement of metal area. Do not encase pipe and fitting joints to flanges.
- C. Install thrust blocks, tie rods, and joint restraint at dead ends of water main.
- D. All concrete thrust blocks shall set for a minimum of 36 hours before any load is applied.

### 3.8 SERVICE CONNECTIONS

- A. All 3/4" and 1" service connections shall be made with CTS tubing and all 2" connections shall be HDPE DR9 in IPS.
- B. Meter setters for 3/4" and 1" shall be A.Y. McDonald model # 724-207WDTD-33 and 724412WDTD-44 respectively. All 2" setters are to be A.Y. McDonald model #720B712WDF 775. The County will provide and set all meters up to 2".
- C. There is to be a 12" brass nipple installed on the back of all setters. Setters shall have a stabilizer bar placed through them to ensure an upright position is maintained.
- D. The contractor shall provide and set any meters 3" and larger. Meter must be approved by the Camden County and Engineer prior to placement. These meters shall be placed in a concrete vault with an external bypass. All valves on external bypass shall utilize a 2" operating nut.

### 3.9 BACKFILLING

- A. Backfill in accordance with Section 31 23 17 – Trenching and Backfilling.

### 3.10 DISINFECTION OF POTABLE WATER PIPING SYSTEM

- A. Flush and disinfect system in accordance with Section 33 13 00.

### 3.11 FIELD QUALITY CONTROL

- A. Pressure test system to 150 psi. Repair leaks and re-test.
  1. After completion of pipeline installation, including backfill, but prior to final connection to existing system, conduct, in presence of the Public Works Department and/or Engineer concurrent hydrostatic pressure and leakage tests in accordance with AWWA C600.
  2. A minimum 48 hour notice is required to be given to the County prior to pressure test.
  3. Prior to pressure testing of buried piping, backfill shall have been placed and tamped to provide adequate support for all pipe and fittings, and reaction backing shall have been in place at least 5 days.
  4. Provide equipment required to perform leakage and hydrostatic pressure tests.
  5. Test Pressure: Not less than 150 psi or 50 psi in excess of maximum static pressure, whichever is greater.

6. Conduct hydrostatic test for at least two-hour duration.
7. No more than 2500 linear feet of water line will be test at one time.
8. No pipeline installation will be approved when pressure varies by more than 5 psi at completion of hydrostatic pressure test.
9. Before applying test pressure, completely expel air from section of piping under test. Provide corporation cocks so air can be expelled as pipeline is filled with water. After air has been expelled, close corporation cocks and apply test pressure. At conclusion of tests, remove corporation cocks and plug the resulting piping openings.
10. Slowly bring piping to test pressure and allow system to stabilize prior to conducting leakage test. Do not open or close valves at differential pressures above rated pressure.
11. Examine exposed piping, fittings, valves, hydrants, and joints carefully during hydrostatic pressure test. Repair or replace damage or defective pipe, fittings, valves, hydrants, or joints discovered, following pressure test.
12. No pipeline installation will be approved when leakage is greater than that determined by the following formula:

$L = (SD\sqrt{P})/133,200$
L = allowable, in gallons per hour
S = length of pipe tested, in inches
D = nominal diameter of pipe, in inches
P = average test pressure during leakage test, in pounds per square inch (gauge)

13. When leakage exceeds specified acceptable rate, locate source and make repairs. Repeat test until specified leakage requirements are met.
- B. When tests indicate Work does not meet specified requirements, remove Work, replace and retest.

END OF SECTION

## SECTION 33 13 00

## DISINFECTING OF WATER DISTRIBUTION

## PART 1 GENERAL

## 1.1 RELATED DOCUMENTS

- A. The Proposal-Agreement Section of the Contract and other sections of this Division apply to the work in this Section.

## 1.2 SUMMARY

- A. Section Includes:
  - 1. Disinfection of potable water distribution system
  - 2. Testing and reporting results.

## 1.3 MEASUREMENT AND PAYMENT

- A. Disinfection: No payment will be made for disinfection of water distribution piping. Cost of disinfection shall be included in the unit price bid for size and type of pipe material.

## 1.4 REFERENCES

- A. American Water Works Association:
  - 1. AWWA B303 - Sodium Chlorite.
  - 2. AWWA C600 - Installation of Ductile-Iron Water Mains and Their Appurtenances.
  - 3. AWWA C651 - Disinfecting Water Mains.

## 1.5 SUBMITTALS

- A. Product Data: Submit procedures, proposed chemicals, and treatment levels for review.
- B. Disinfection Report:
  - 1. Type and form of disinfectant used.
  - 2. Date and time of disinfectant injection start and time of completion.
  - 3. Test locations.
  - 4. Name of person collecting samples.
  - 5. Initial and 24-hour disinfectant residuals in treated water in ppm for each outlet tested.
  - 6. Date and time of flushing start and completion.
  - 7. Disinfectant residual after flushing in ppm for each outlet tested.
- C. Bacteriological Report:
  - 1. Date issued, project name, and testing laboratory name, address, and telephone number.
  - 2. Time and date of water sample collection.

3. Name of person collecting samples.
4. Test locations.
5. Initial and 24-hour disinfectant residuals in ppm for each outlet tested.
6. Coliform bacteria test results for each outlet tested.

#### 1.6 QUALITY ASSURANCE

- A. Perform Work in accordance with AWWA C651.

#### 1.7 QUALIFICATIONS

- A. Testing Firm: For this project, the Contractor shall have all bacteriological testing done by a testing laboratory approved by the Albemarle Regional Health Department and The Camden County Water & Sewer District.
- B. Submit bacteriologist's signature and authority associated with testing.

### PART 2 PRODUCTS

#### 2.1 DISINFECTION CHEMICALS

- A. Chemicals: AWWA B303, Sodium Chlorite.

### PART 3 EXECUTION

#### 3.1 EXAMINATION AND PREPARATION

- A. Verify piping system has been cleaned, inspected, and pressure tested.
- B. Perform scheduling and disinfecting activity with start-up, water pressure testing, adjusting and balancing, demonstration procedures, including coordination with related systems.

#### 3.2 INSTALLATION

- A. Before being placed into service, and before certification of completion by the Public Works Department and/or Engineer, all new water systems, or extensions to existing systems or valved section of such extensions, or any replacement in the existing water system, or any exposed section of the existing system shall be disinfected, according to the requirements of the North Carolina Administrative Code Title 15A, Subchapter 18C, Section .1000.
- B. “.2201 DISINFECTION OF NEW SYSTEMS”
  1. All interior surfaces of new potable water supply systems, including wells, filters, storage tanks and distribution lines shall be thoroughly disinfected by means of

hypochlorite or chlorine solutions, after which bacteriological test samples shall be collected.

2. After disinfection the water supply shall not be placed into service until bacteriological test results of representative water samples analyzed in an approved laboratory are found to be satisfactory.”

C. “.2203 DISINFECTION OF STORAGE TANKS AND DISTRIBUTION SYSTEMS”

1. Water distribution systems, including storage tanks and water mains, after flushing to remove sediment and other foreign matter, and after testing for leaks, shall be disinfected by the addition and thorough dispersion of a chlorine solution in concentrations sufficient to produce a chlorine residual of at least 50 milligrams per liter (or ppm) in the water throughout the distribution system, including all water mains and storage tanks.
2. The chlorine solution shall remain in contact with interior surfaces of the water system for a period of 24 hours. Then the water system shall be flushed with fresh water from an approved water source until the chlorine solution is dispelled. All piping systems shall be thoroughly flushed by providing a velocity of 2 feet per second in the line being flushed.
3. Representative samples of the water shall then be collected when residual chlorine concentration is approximately 2 ppm. If bacteriological tests of the samples indicate that the water quality is satisfactory, the water mains and storage tanks may be placed in service.
4. In unusual situations where large volume tanks are involved and where there is not sufficient water available to fill the tank or there is not available a suitable drainage area for the chlorinated water, an alternate disinfection procedure for tanks may be proposed. Such proposal must be submitted in writing completely describing the proposed disinfection procedure and substantiating the need for an alternate procedure in the particular circumstance. Such alternate procedure must be approved before being implemented. The conclusion of the department shall be final.”

- D. At locations where new water lines are to be tied into the existing system, the interior of all new fittings and valves required shall be bathed with a concentrated chlorine solution at the time of installation. Water shall be flushed through the new valve a sufficient time to wash out the chlorine solution before closing the valve and installing additional pipe. The new valve shall remain closed until the new section of pipe to be installed has passed all tests.

- E. The Contractor shall be required to make arrangements for having tests conducted. All expenses incurred in making tests shall be borne by the Contractor and should be included in his bid per linear foot of pipe material.

### 3.3 FIELD QUALITY CONTROL

A. Disinfection and Flushing:

1. Disinfect pipeline installation in accordance with AWWA C651. Use of liquid chlorine is not permitted.

2. Upon completion of retention period required for disinfection, flush pipeline until chlorine concentration in water leaving pipeline is no higher than that generally prevailing in existing system or is acceptable for domestic use.
3. Legally dispose of chlorinated water. When chlorinated discharge may cause damage to environment, apply neutralizing chemical to chlorinated water to neutralize chlorine residual remaining in water.
4. Chlorine solution shall be collected in an approved container and dechlorinated using one of the following solutions or an approved equivalent: Sulfur Dioxide, Sodium Bisulfite, Sodium Sulfite, or Sodium Thiosulfate. Dechlorinated water shall be disposed of on site.
5. In the case that two consecutive bacteriological test fail, the line shall be "pigged". The type of "pig" must be approved by the County. This practice is only for pipes 8" and larger.

END OF SECTION

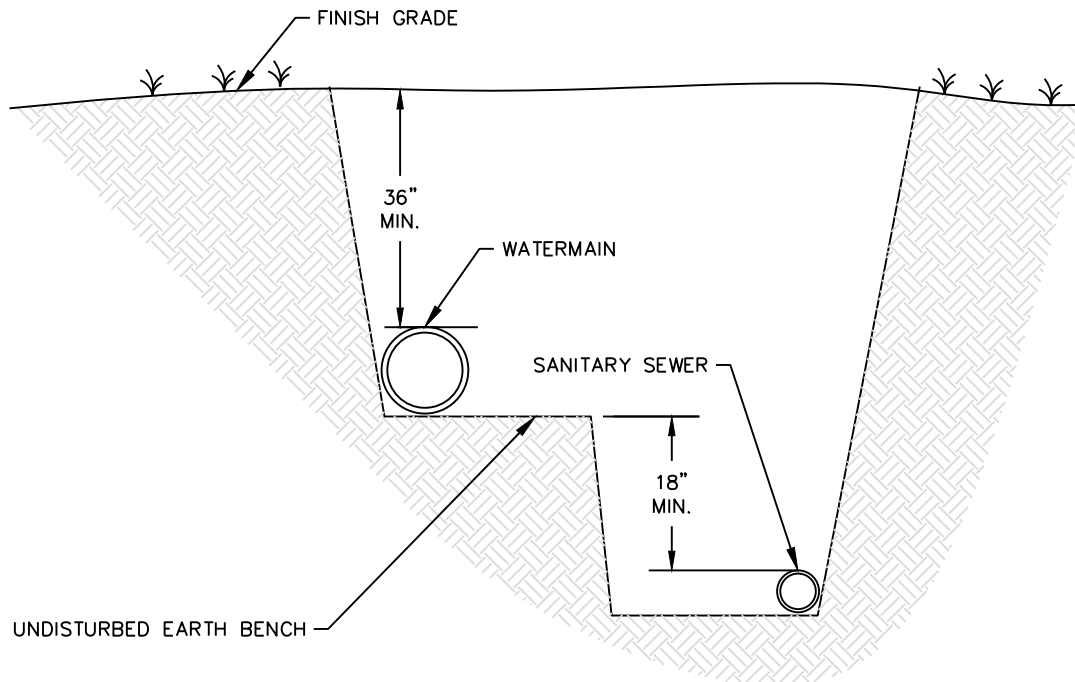

## BENCHED WATER & SEWER PLACEMENT

NTS





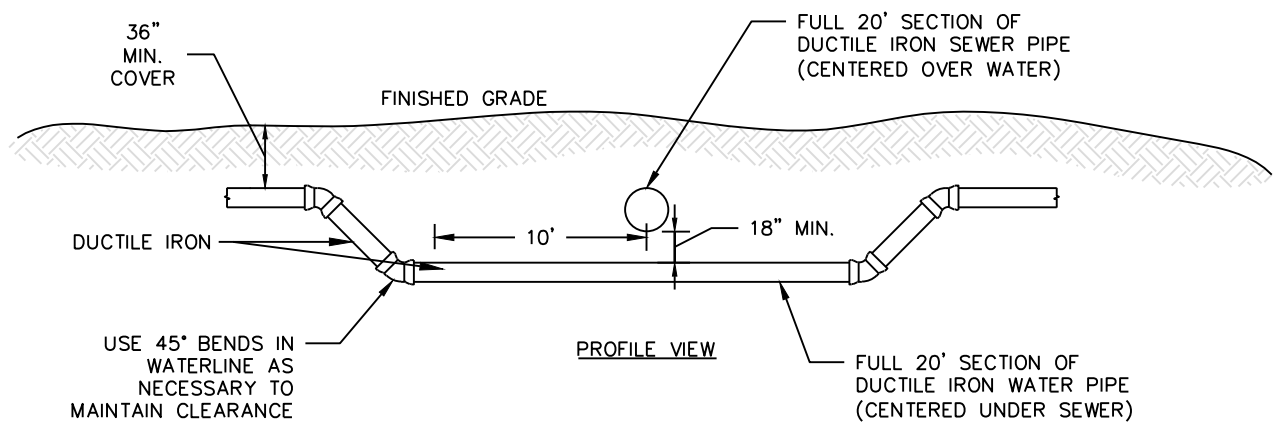
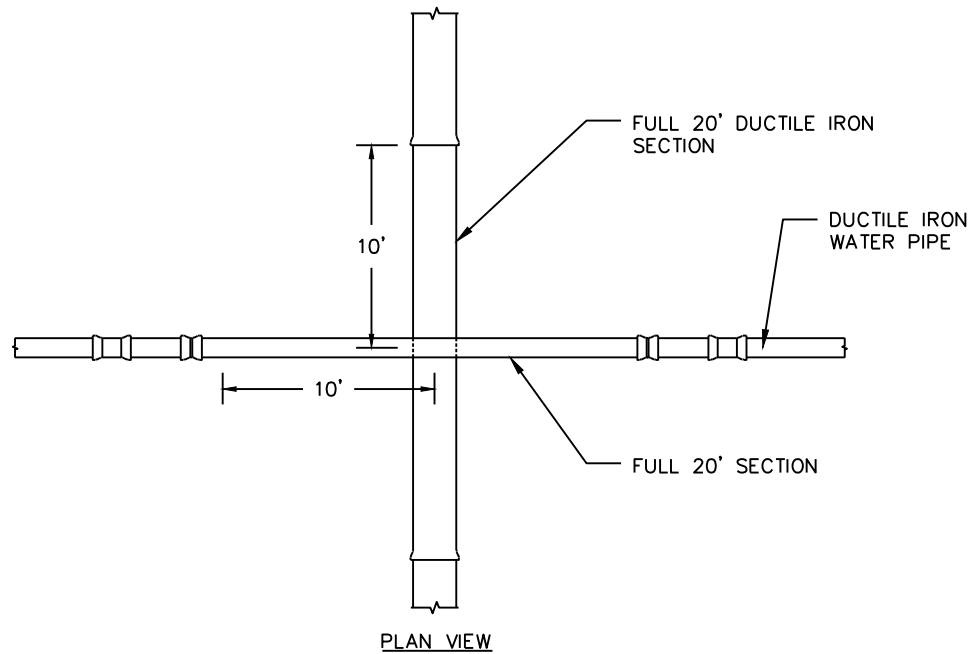

# WATER/SEWER CROSSING DETAIL

NTS



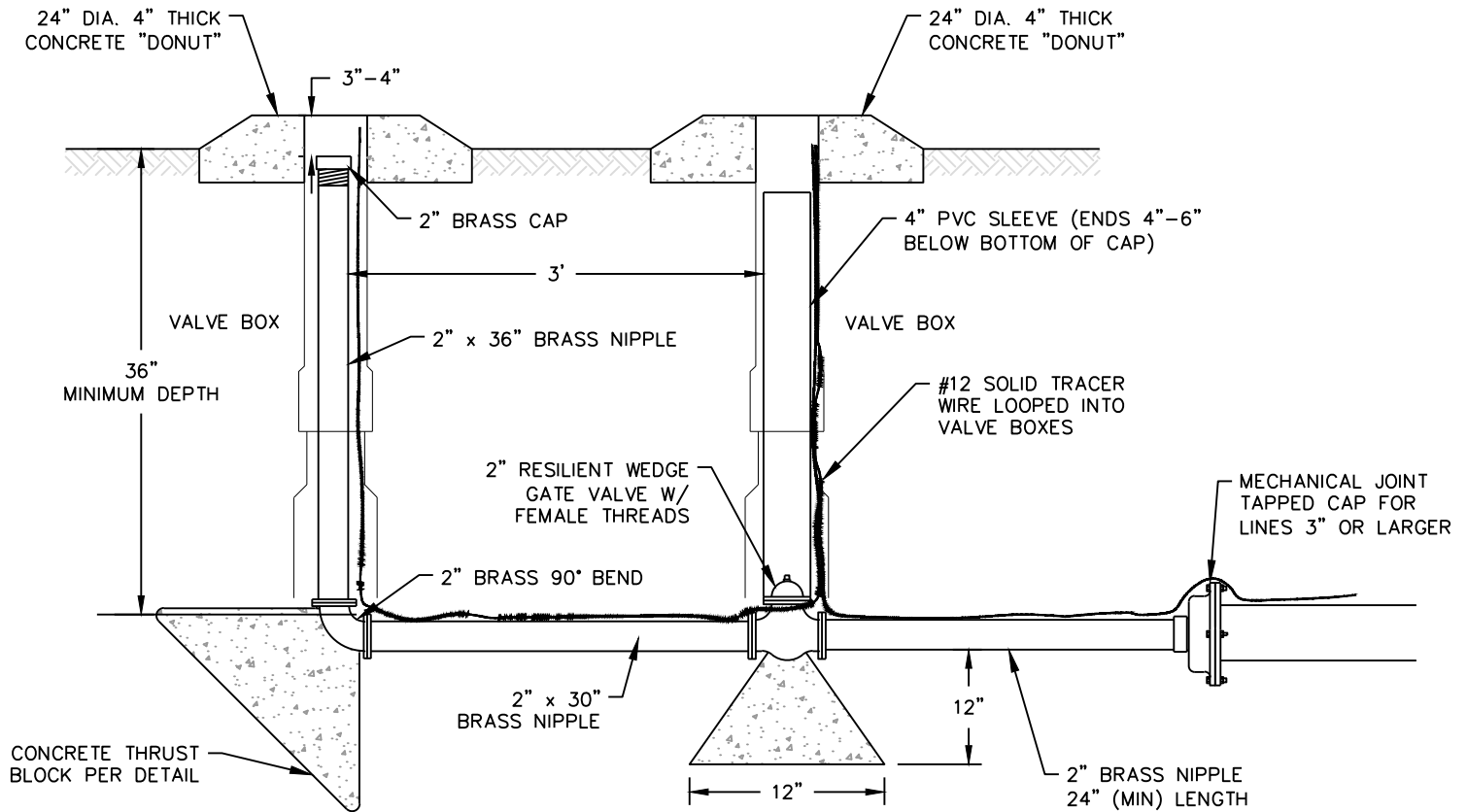

**NOTES:**  
 1. VALVE BOX COVERS SHALL BE MARKED WITH A "W".  
 2. BELL RESTRAINTS TO BE USED ON THE THREE BELLS PRIOR TO TAPPED CAP.

## 2" BLOW-OFF DETAIL

NTS



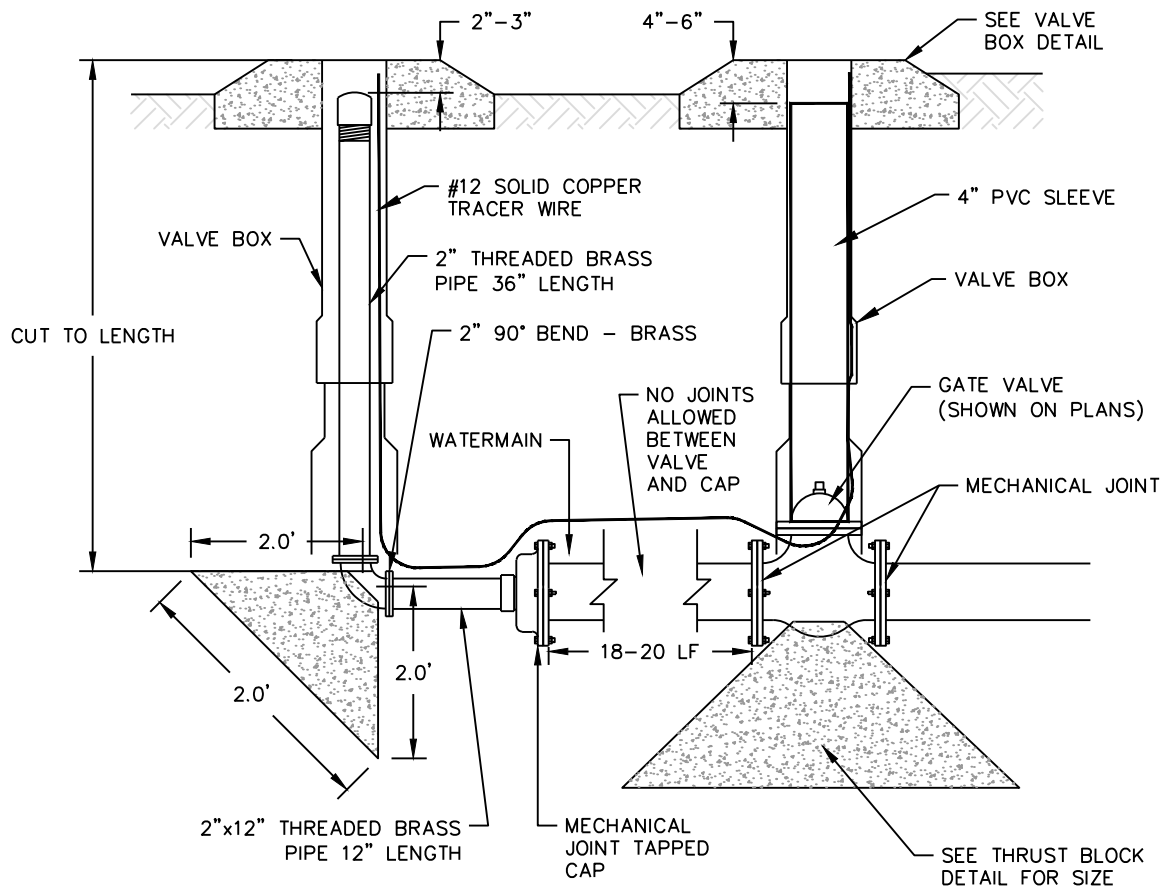

**NOTES**

1. VALVE BOX COVERS SHALL BE MARKED WITH A "W".
2. NO THREADED ROD ALLOWED. MUST USE ROMAC OR MEGALUG JOINT RESTRAINT AT VALVE.
3. INSTALL BELL RESTRAINT (ROMAC SERIES 600) AT A LOCATION ONE JOINT UPSTREAM FROM GATE VALVE.

# TEMPORARY BLOW-OFF DETAIL

NTS



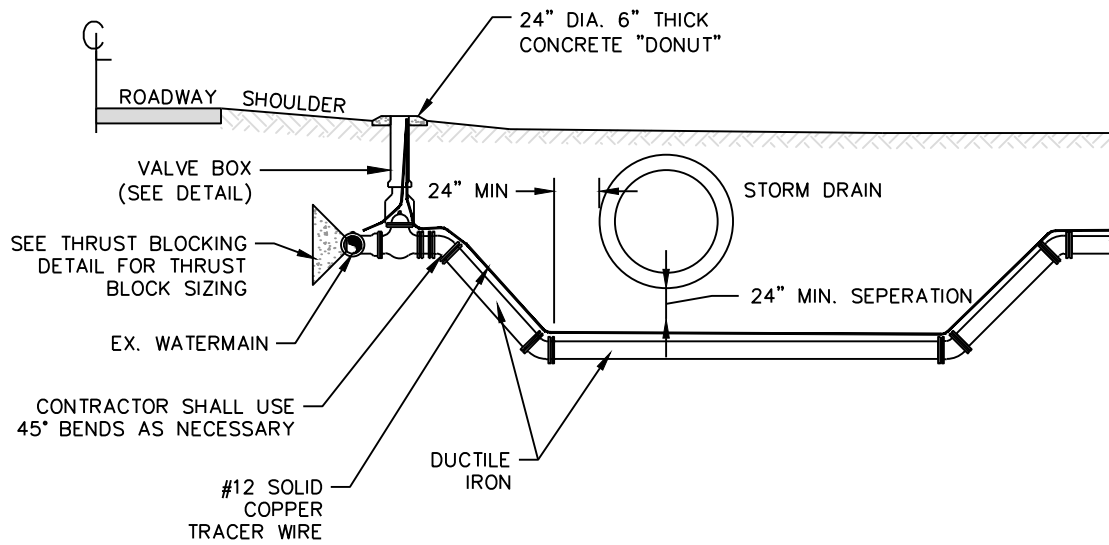

**NOTE**

1. ALL FITTINGS ARE TO BE BLOCKED PER THE SPECIFICATION
2. IF OFFSET CONTAINS ANY JOINTS, BELL RESTRAINT MUST BE INSTALLED (ROMAC SERIES 600)

# CULVERT CROSSING DETAIL

NTS





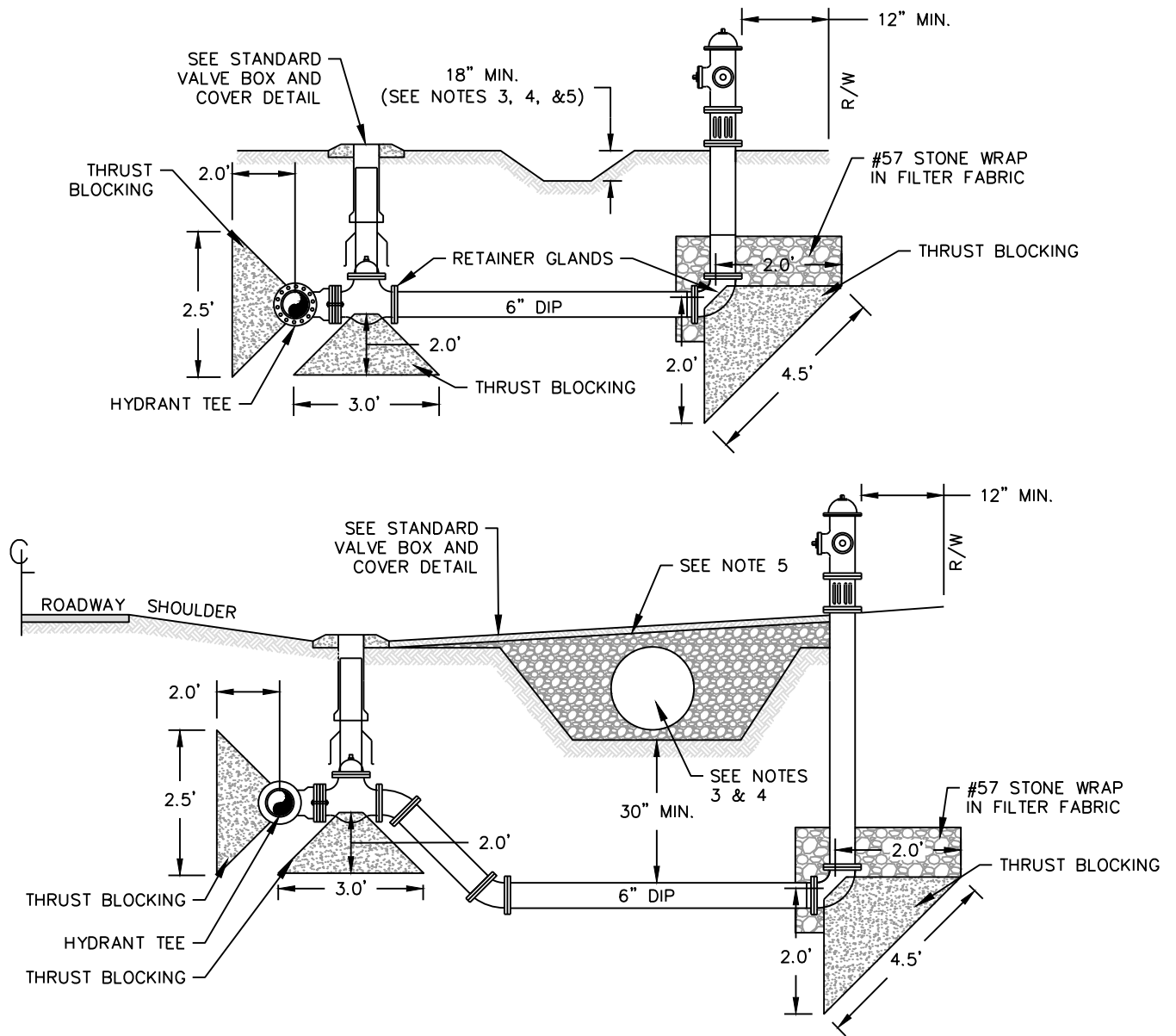

- NOTES
1. HYDRANT TO BE SET WITH BREAKABLE COUPLING APPROXIMATELY 3" ABOVE FINISHED GRADE.
  2. STEAMER NOZZLES IS TO FACE ROADWAY UNLESS OTHERWISE NOTED.
  3. CULVERT PIPE IS REQUIRED IF DITCH DEPTH (EDGE OF PAVEMENT TO BOTTOM OF DITCH) IS 18" OR MORE, OR HYDRANT VALVE FALLS WITHIN DITCH SLOPE.
  4. SIZE OF CULVERT PIPE (HDPE PIPE) IS TO BE APPROVED BY LOCALITY.
  5. PROVIDE 6" MINIMUM COVER ON CULVERT AND 4" MINIMUM TOP SOIL AND SEED. BED PIPE WITH WITH #57 OR #67 STONE.
  6. TRACER WIRE REQUIRED.

# HYDRANT DITCH CROSSING DETAIL

NTS



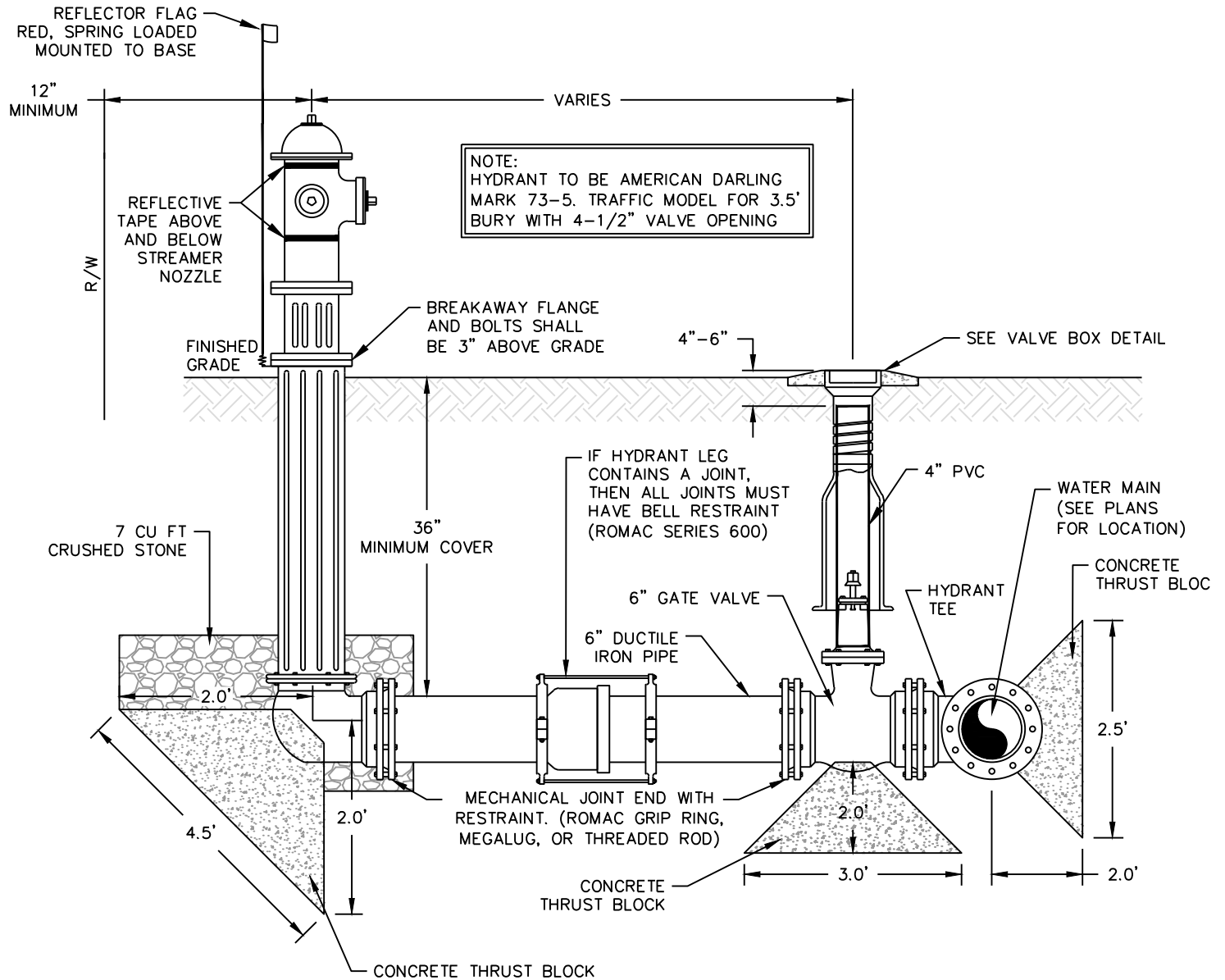

- NOTES:
- DO NOT BLOCK HYDRANT DRAIN WITH THRUST BLOCKING
  - COAT TIE RODS & NUTS WITH EPOXY
  - DO NOT SUPPORT VALVE BOX DIRECTLY ON VALVE
  - ALL JOINTS SHALL BE MECHANICAL JOINTS
  - HYDRANT SHALL FACE ROAD
  - NO STORZ CONNECTORS
  - INSTALL REFLECTIVE HYDRANT MARKER, EBERL IRON WORKS, HYDRA-FINDER WITH SPRING AND MINI FLAG, RED. MOUNT FLAG BASE OF HYDRANT.
  - PLACE REFLECTIVE TAPE AROUND HYDRANT BARREL, ABOVE AND BELOW STREAMER NOZZLE.
  - IF 45° FITTINGS ARE INSTALLED TO COMPENSATE GRADE, GRIP RINGS SHALL BE USED.

# FIRE HYDRANT DETAIL

NTS



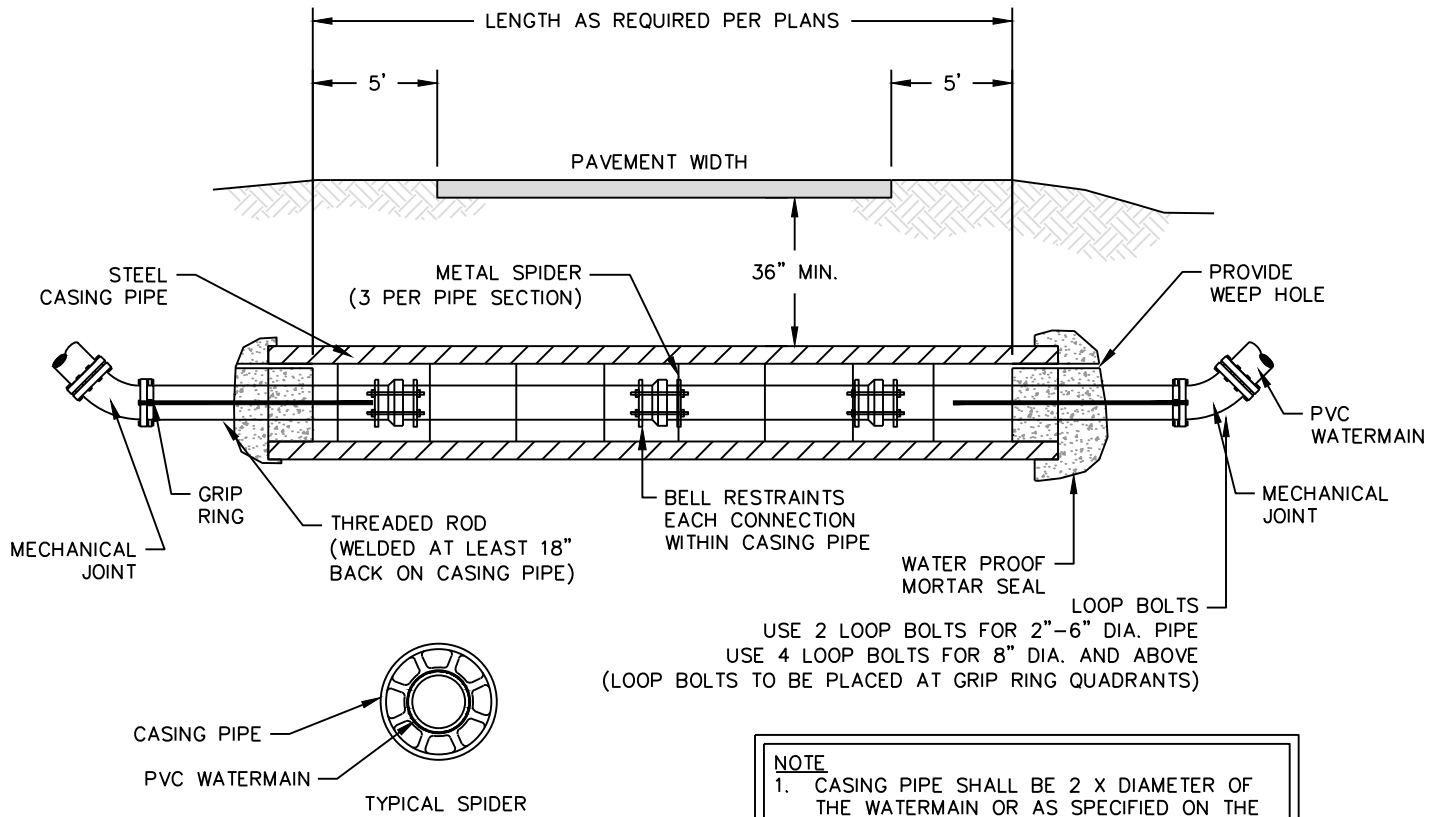

**NOTE**

- CASING PIPE SHALL BE 2 X DIAMETER OF THE WATERMAIN OR AS SPECIFIED ON THE PLANS CASING PIPE TO BE STEEL PIPE (ASTM 252, GRADE 2 OR 3) WALL THICKNESS TO MEET NCDOT SPECIFICATIONS
- TIE END OF CASING PIPE TO FIRST FITTING OR VALVE WITH THREADED ROD

## STEEL CASING DETAIL

NTS



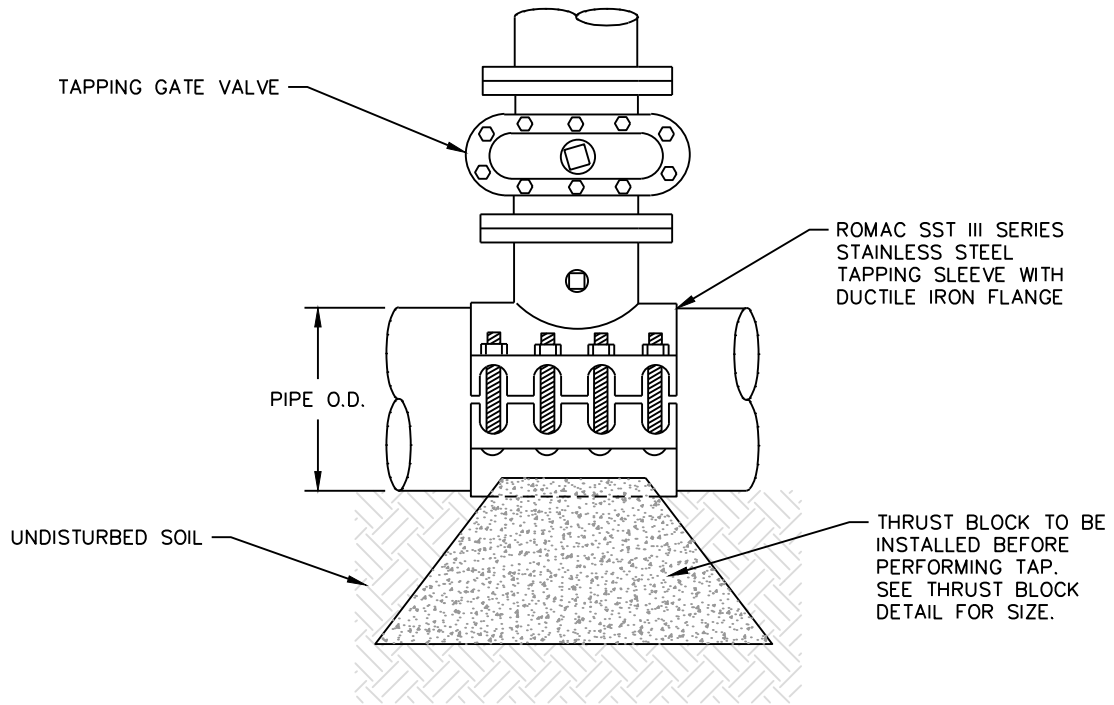

NOTES

1. TAPPING SLEEVE AND VALVE TO BE OF TYPE AND MANUFACTURE APPROVED BY CAMDEN COUNTY.
2. TAP SHALL BE PERFORMED IN THE PRESENCE OF A REPRESENTATIVE OF CAMDEN COUNTY WATER DEPARTMENT AND THE ENGINEER.
3. ALL COUPONS SHALL BE DELIVERED TO THE OWNER OR TO CAMDEN COUNTY.
4. TAPPING SLEEVE AIR TEST SHALL BE PERFORMED AT 100 PSI FOR 15 MINUTES (FILL WITH WATER, THEN PERFORM AIR TEST).

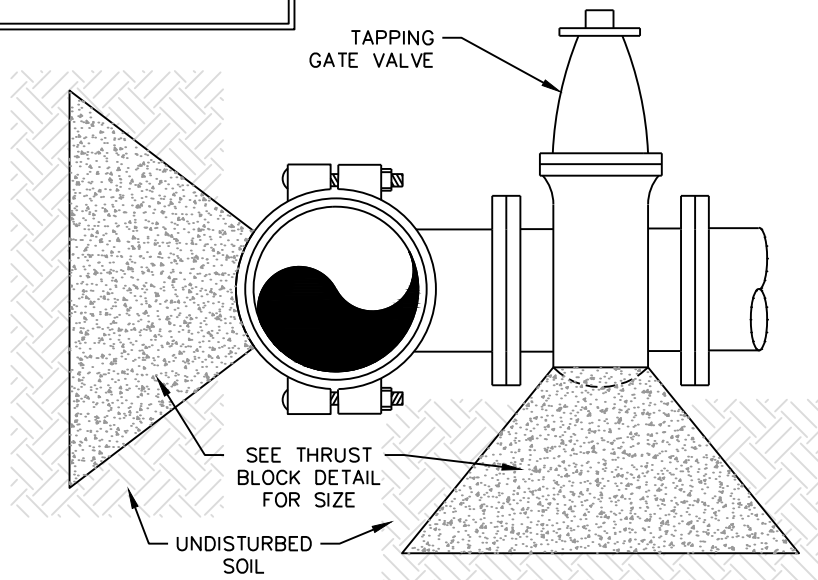

# TAPPING DETAIL

NTS





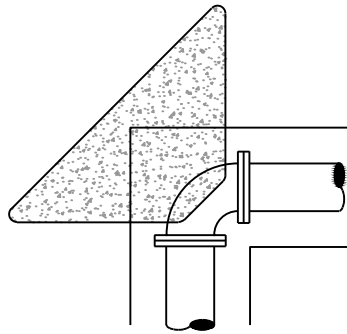

PLAN 90°

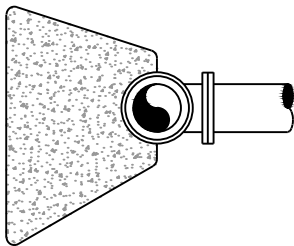

SECTION 90° & TEE

NOTE:  
GRIP RINGS MAY BE USED ON PIPE UP TO 12" IN DIAMETER IN LIEU OF BLOCKING IN SOME LOCATIONS. USE OF GRIP RINGS SHALL BE BY PRIOR APPROVAL OF THE CAMDEN COUNTY ENGINEERING DEPT. PIPE 14" AND LARGER SHALL UTILIZE STAR-GRIP OR EQUIVALENT RETAINER GLANDS AND SHALL INSTALL CONCRETE THRUST BLOCKING PER THIS DETAIL.

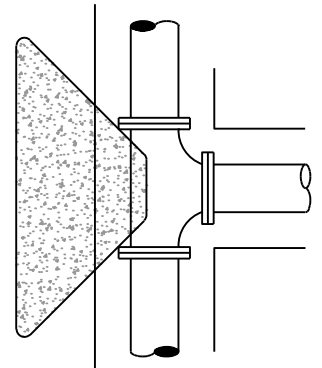

PLAN TEE

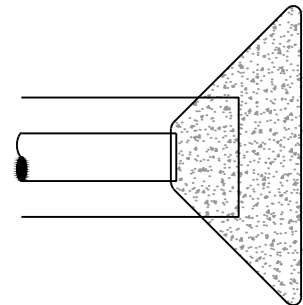

PLAN PLUG

CONCRETE THRUST BLOCK SCHEDULE

FITTING	PIPE SIZE (NOM. DIA. IN INCHES)									
	2"	4"	6"	8"	10"	12"	16"	18"	20"	24"
TEE / PLUGS	1.6	1.9	2.8	3.8	4.7	5.9	7.5	8.5	9.4	11.3
90° BEND	1.5	1.9	2.8	3.8	4.7	5.9	7.5	8.5	9.4	11.3
45° BEND	1.0	1.4	2.1	2.8	3.5	4.3	5.5	6.2	6.9	7.7
22 1/2° BEND	.8	1.0	1.5	2.0	2.5	3.1	4.0	4.5	4.9	5.5

TABLE "A" DIMENSIONS (IN FEET)

# THRUST BLOCK DETAIL

NTS



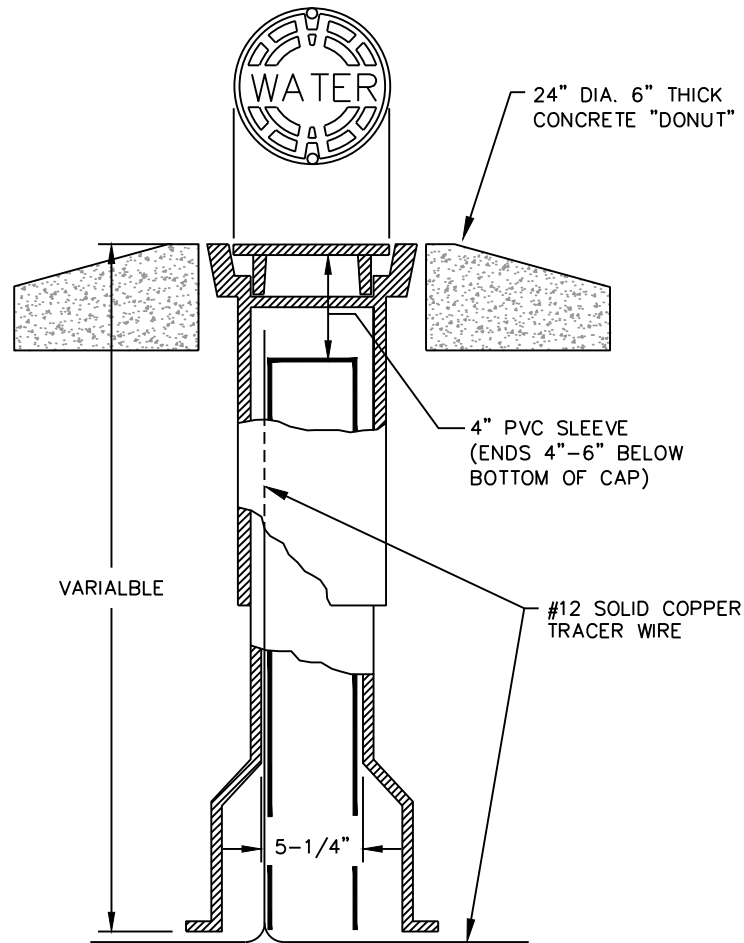

TWO PIECE SCREW TYPE  
ADJUSTABLE VALVE BOX  
(5-1/4" SHAFT)

---

# VALVE BOX

---

NTS



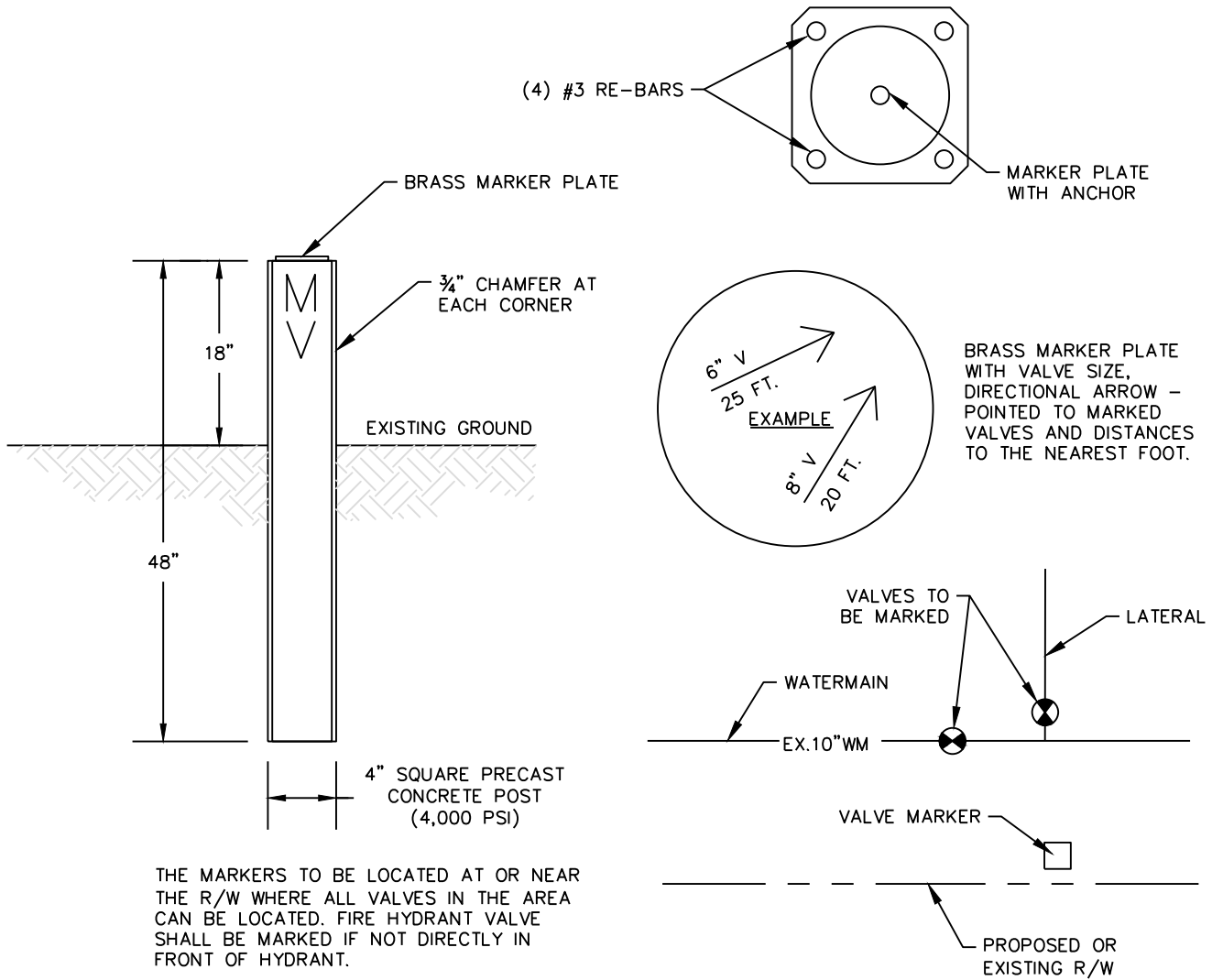

# VALVE MARKER DETAIL

NTS



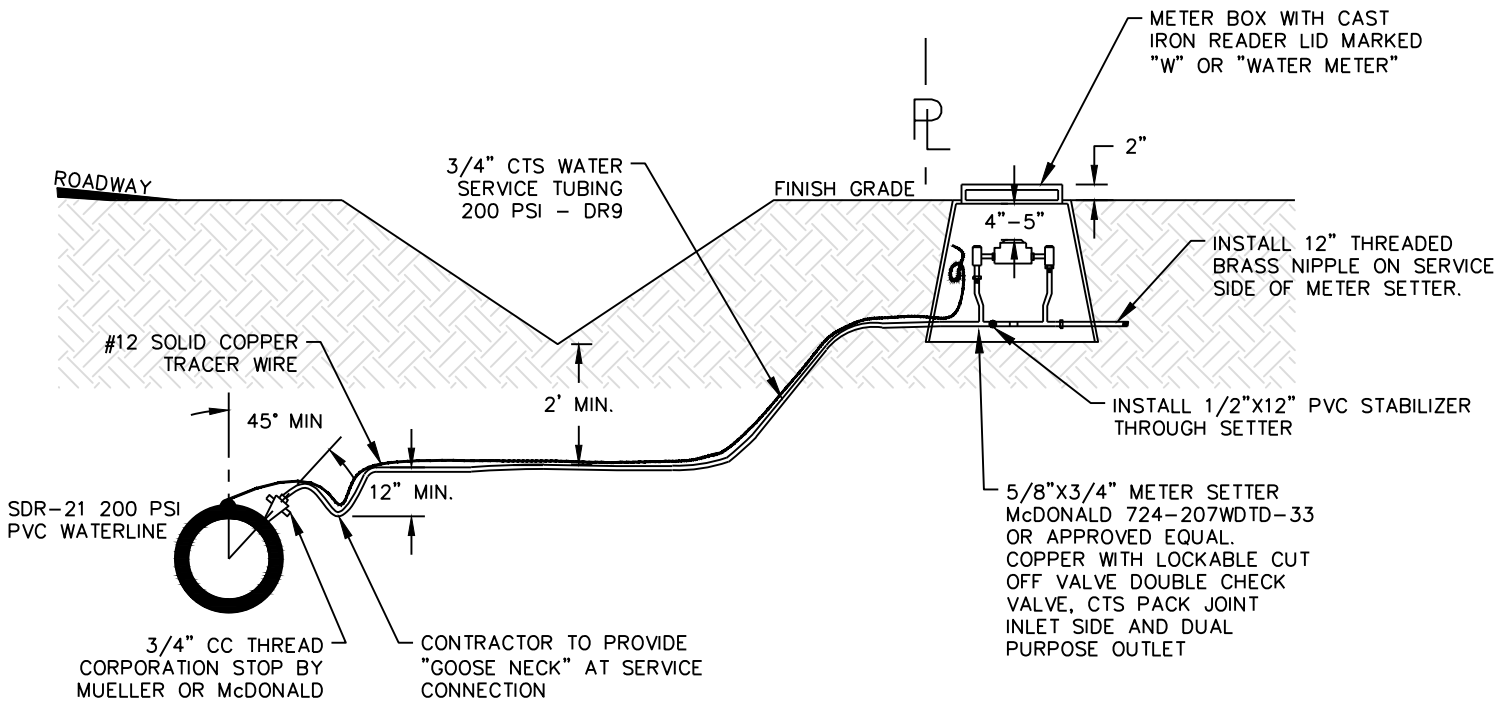

- NOTES:
1. SERVICE SADDLE SHALL BE SINGLE BRONZE STRAP, TWO PIECE BOLTED, CC THREAD, BY McDONALD, MUELLER, OR APPROVED EQUAL SIZED AS REQUIRED. 2" AND UP REQUIRE DOUBLE STRAP SADDLE, USE STAINLESS STRAP FOR 12" PIPE AND LARGER.
  2. CONTRACTOR TO FURNISH AND INSTALL PLASTIC METER BOX WITH CAST IRON READER LID AND METER SETTER (BY MUELLER OR McDONALD) TO MEET CAMDEN COUNTY STANDARDS.

# 3/4" WATER SERVICE LATERAL DETAIL

NTS





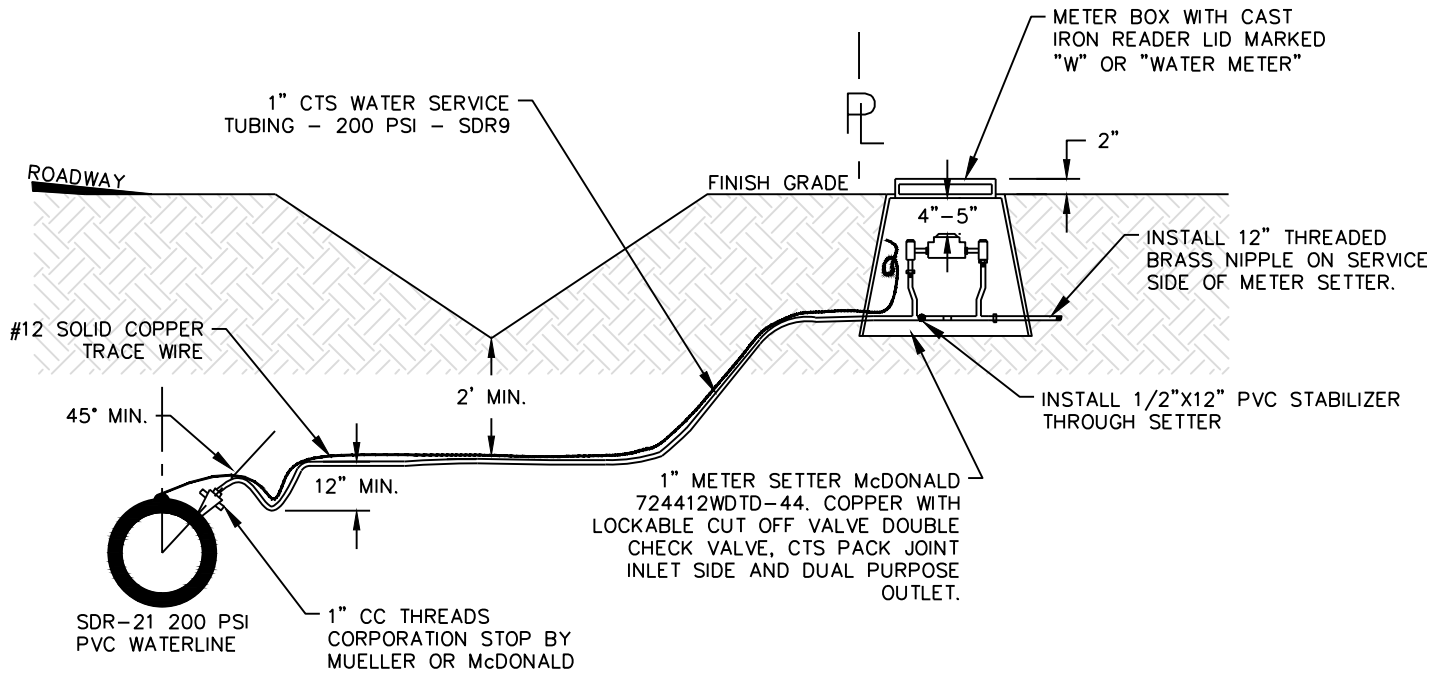

- NOTES:
1. SERVICE SADDLE SHALL BE SINGLE BRONZE STRAP, TWO PIECE BOLTED, CC THREAD, BY McDONALD, MUELLER, OR APPROVED EQUAL SIZED AS REQUIRED. 2" AND UP REQUIRE DOUBLE STRAP SADDLE, USE STAINLESS STRAP FOR 12" PIPE AND LARGER.
  2. CONTRACTOR TO FURNISH AND INSTALL PLASTIC METER BOX WITH CAST IRON READER LID AND METER SETTER (BY MUELLER OR McDONALD) TO MEET CAMDEN COUNTY STANDARDS.

# 1" WATER SERVICE LATERAL DETAIL

NTS

**Camden County Board of Commissioners  
AGENDA ITEM SUMMARY SHEET**

**Item Number:**

**INFORMATION**

**Meeting Date:** September 21<sup>st</sup>, 2015  
**Attachments:** 9  
**Submitted By:** Various Department Heads

**ITEM TITLE:** INFORMATION

**SUMMARY:**

- A. Sales Tax Report – July & August
- B. Camden County Economic Development
- C. Sheriff's Monthly Report - August
- D. Albemarle RC&D Annual Report 2014-2015
- E. Letter from Senator Richard Burr
- F. EMS Response Times – July
- G. EMS Monthly Reports – August & September
- H. 2015 Eastern 4-H Shooting Sports
- I. Thank you Letter from College of the Albemarle

**RECOMMENDATION:**

<b>MOTION MADE BY:</b>	
S. Duckwall	
G. Meiggs	
M. McLain	
C. Riggs	
T. White	
NO MOTION	
<b>VOTE:</b>	
S. Duckwall	
G. Meiggs	
M. McLain	
C. Riggs	
T. White	
ABSENT	
RECUSED	

Finance														24-Jul-15	
<b>2014-2015</b>															
<b>SALES TAX - REVENUE COLLECTION REPORT</b>															
	July	August	September	October	November	December	January	February	March	April	May	June	Totals	Budgeted	
Art. 39	\$44,058	\$42,111	\$22,402	\$52,255	\$54,114	\$41,782	\$53,444	\$43,525	\$43,288	\$45,900	\$44,030		\$486,908	\$525,000	
Art. 40	\$38,988	\$34,814	\$35,370	\$33,479	\$35,220	\$34,201	\$41,563	\$31,886	\$30,973	\$32,613	\$34,850		\$383,958	\$360,000	
Art. 42	\$10,488	\$9,928	\$6,185	\$12,046	\$12,308	\$9,971	\$12,478	\$10,325	\$10,146	\$10,713	\$10,240		\$114,829	\$125,000	
Art. 44	\$53	\$2	\$2	\$3	-\$3	\$0	\$0	-\$11	\$36	-\$11	\$0		\$71		
<b>Totals</b>	<b>\$93,587</b>	<b>\$86,855</b>	<b>\$63,959</b>	<b>\$97,783</b>	<b>\$101,639</b>	<b>\$85,954</b>	<b>\$107,484</b>	<b>\$85,725</b>	<b>\$84,444</b>	<b>\$89,214</b>	<b>\$89,121</b>		<b>\$985,766</b>		
<b>Total Budgeted</b>														<b>\$1,010,000</b>	
<b>SALES TAX REVENUE- SCHOOL CAPITAL RESERVE FUND</b>															
	July	August	September	October	November	December	January	February	March	April	May	June	Totals	Budgeted	
Art. 40	\$16,709	\$14,920	\$15,158	\$14,348	\$15,094	\$14,658	\$17,813	\$13,666	\$13,274	\$13,977	\$14,936		\$164,552	\$150,000	
Art. 42	\$15,732	\$14,892	\$9,278	\$18,069	\$18,462	\$14,957	\$18,717	\$15,488	\$15,220	\$16,069	\$15,360		\$172,243	\$175,000	
<b>Totals</b>	<b>\$32,441</b>	<b>\$29,812</b>	<b>\$24,436</b>	<b>\$32,417</b>	<b>\$33,556</b>	<b>\$29,615</b>	<b>\$36,529</b>	<b>\$29,153</b>	<b>\$28,494</b>	<b>\$30,046</b>	<b>\$30,296</b>		<b>\$336,796</b>		
<b>Total Budgeted</b>														<b>\$325,000</b>	
<b>Grand</b>	<b>\$126,029</b>	<b>\$116,668</b>	<b>\$88,395</b>	<b>\$130,200</b>	<b>\$135,196</b>	<b>\$115,569</b>	<b>\$144,014</b>	<b>\$114,879</b>	<b>\$112,938</b>	<b>\$119,260</b>	<b>\$119,417</b>		<b>\$1,322,565</b>	<b>\$1,335,000</b>	
<b>2013-2014</b>															
<b>SALES TAX COLLECTION REPORT</b>															
	July	August	September	October	November	December	January	February	March	April	May	June	Totals	Budgeted	
Art. 39	\$53,092	\$38,025	\$38,971	\$30,890	\$51,669	\$41,573	\$55,223	\$40,074	\$40,883	\$51,855	\$40,845	\$45,708	\$528,808	\$510,000	
Art.40	\$34,973	\$34,445	\$31,096	\$31,650	\$26,845	\$32,596	\$36,408	\$26,977	\$30,000	\$32,869	\$30,716	\$35,340	\$383,915	\$350,000	
Art. 42	\$12,264	\$9,051	\$12,634	\$7,734	\$11,604	\$9,849	\$12,618	\$9,463	\$9,589	\$11,955	\$9,637	\$10,706	\$127,104	\$120,000	
Art. 44	\$3	\$2	\$14	\$292	\$2	\$2	\$4	\$24	\$224	\$2	\$4	-\$9	\$564		
<b>Totals</b>	<b>\$100,332</b>	<b>\$81,523</b>	<b>\$82,715</b>	<b>\$70,567</b>	<b>\$89,956</b>	<b>\$84,020</b>	<b>\$104,253</b>	<b>\$76,538</b>	<b>\$80,696</b>	<b>\$96,681</b>	<b>\$81,202</b>	<b>\$91,745</b>	<b>\$1,039,827</b>		
<b>Total budgeted</b>														<b>\$980,000</b>	
<b>SCHOOL CAPITAL RESERVE FUND</b>															
	July	August	September	October	November	December	January	February	March	April	May	June	Totals	Budgeted	
Art. 40															
Art. 42															
<b>Totals</b>	<b>\$12,264</b>	<b>\$9,051</b>	<b>\$12,634</b>	<b>\$7,734</b>	<b>\$11,604</b>	<b>\$9,849</b>	<b>\$12,618</b>	<b>\$9,463</b>	<b>\$9,589</b>	<b>\$11,955</b>	<b>\$9,637</b>	<b>\$10,706</b>	<b>\$127,104</b>		
<b>Total Budgeted</b>														<b>\$120,000</b>	
<b>Grand</b>	<b>\$112,596</b>	<b>\$90,574</b>	<b>\$95,349</b>	<b>\$78,301</b>	<b>\$101,560</b>	<b>\$93,869</b>	<b>\$116,871</b>	<b>\$86,001</b>	<b>\$90,285</b>	<b>\$108,636</b>	<b>\$90,839</b>	<b>\$102,451</b>	<b>\$1,167,332</b>	<b>\$1,100,000</b>	

Finance 17-Aug-15

**2014-2015****SALES TAX - REVENUE COLLECTION REPORT**

	July	August	September	October	November	December	January	February	March	April	May	June	Totals	Budgeted
Art. 39	\$44,058	\$42,111	\$22,402	\$52,255	\$54,114	\$41,782	\$53,444	\$43,525	\$43,288	\$45,900	\$44,030	\$42,237	\$529,146	\$525,000
Art. 40	\$38,988	\$34,814	\$35,370	\$33,479	\$35,220	\$34,201	\$41,563	\$31,886	\$30,973	\$32,613	\$34,850	\$37,517	\$421,476	\$360,000
Art. 42	\$10,488	\$9,928	\$6,185	\$12,046	\$12,308	\$9,971	\$12,478	\$10,325	\$10,146	\$10,713	\$10,240	\$10,172	\$125,000	\$125,000
Art. 44	\$53	\$2	\$2	\$3	-\$3	\$0	\$0	-\$11	\$36	-\$11	\$0	\$0	\$71	
<b>Totals</b>	<b>\$93,587</b>	<b>\$86,855</b>	<b>\$63,959</b>	<b>\$97,783</b>	<b>\$101,639</b>	<b>\$85,954</b>	<b>\$107,484</b>	<b>\$85,725</b>	<b>\$84,444</b>	<b>\$89,214</b>	<b>\$89,121</b>	<b>\$89,927</b>	<b>\$1,075,692</b>	
<b>Total Budgeted</b>														<b>\$1,010,000</b>

**SALES TAX REVENUE- SCHOOL CAPITAL RESERVE FUND**

	July	August	September	October	November	December	January	February	March	April	May	June	Totals	Budgeted
Art. 40	\$16,709	\$14,920	\$15,158	\$14,348	\$15,094	\$14,658	\$17,813	\$13,666	\$13,274	\$13,977	\$14,936	\$16,079	\$180,631	\$150,000
Art. 42	\$15,732	\$14,892	\$9,278	\$18,069	\$18,462	\$14,957	\$18,717	\$15,488	\$15,220	\$16,069	\$15,360	\$15,257	\$187,501	\$175,000
<b>Totals</b>	<b>\$32,441</b>	<b>\$29,812</b>	<b>\$24,436</b>	<b>\$32,417</b>	<b>\$33,556</b>	<b>\$29,615</b>	<b>\$36,529</b>	<b>\$29,153</b>	<b>\$28,494</b>	<b>\$30,046</b>	<b>\$30,296</b>	<b>\$31,336</b>	<b>\$368,132</b>	
<b>Total Budgeted</b>														<b>\$325,000</b>
<b>Grand</b>	<b>\$126,029</b>	<b>\$116,668</b>	<b>\$88,395</b>	<b>\$130,200</b>	<b>\$135,196</b>	<b>\$115,569</b>	<b>\$144,014</b>	<b>\$114,879</b>	<b>\$112,938</b>	<b>\$119,260</b>	<b>\$119,417</b>	<b>\$121,263</b>	<b>\$1,443,824</b>	<b>\$1,335,000</b>

**2013-2014****SALES TAX COLLECTION REPORT**

	July	August	September	October	November	December	January	February	March	April	May	June	Totals	Budgeted
Art. 39	\$53,092	\$38,025	\$38,971	\$30,890	\$51,669	\$41,573	\$55,223	\$40,074	\$40,883	\$51,855	\$40,845	\$45,708	\$528,808	\$510,000
Art. 40	\$34,973	\$34,445	\$31,096	\$31,650	\$26,845	\$32,596	\$36,408	\$26,977	\$30,000	\$32,869	\$30,716	\$35,340	\$383,915	\$350,000
Art. 42	\$12,264	\$9,051	\$12,634	\$7,734	\$11,604	\$9,849	\$12,618	\$9,463	\$9,589	\$11,955	\$9,637	\$10,706	\$127,104	\$120,000
Art. 44	\$3	\$2	\$14	\$292	\$2	\$2	\$4	\$24	\$224	\$2	\$4	-\$9	\$564	
<b>Totals</b>	<b>\$100,332</b>	<b>\$81,523</b>	<b>\$82,715</b>	<b>\$70,567</b>	<b>\$89,956</b>	<b>\$84,020</b>	<b>\$104,253</b>	<b>\$76,538</b>	<b>\$80,696</b>	<b>\$96,681</b>	<b>\$81,202</b>	<b>\$91,745</b>	<b>\$1,039,827</b>	
<b>Total budgeted</b>														<b>\$980,000</b>

**SCHOOL CAPITAL RESERVE FUND**

	July	August	September	October	November	December	January	February	March	April	May	June	Totals	Budgeted
Art. 40														
Art. 42														
<b>Totals</b>	<b>\$12,264</b>	<b>\$9,051</b>	<b>\$12,634</b>	<b>\$7,734</b>	<b>\$11,604</b>	<b>\$9,849</b>	<b>\$12,618</b>	<b>\$9,463</b>	<b>\$9,589</b>	<b>\$11,955</b>	<b>\$9,637</b>	<b>\$10,706</b>	<b>\$127,104</b>	
<b>Total Budgeted</b>														<b>\$120,000</b>
<b>Grand</b>	<b>\$112,596</b>	<b>\$90,574</b>	<b>\$95,349</b>	<b>\$78,301</b>	<b>\$101,560</b>	<b>\$93,869</b>	<b>\$116,871</b>	<b>\$86,001</b>	<b>\$90,285</b>	<b>\$108,636</b>	<b>\$90,839</b>	<b>\$102,451</b>	<b>\$1,167,332</b>	<b>\$1,100,000</b>



















## Camden County Sheriff's Office Monthly Stats

### August-15

### Sheriff Tony Perry

Date		Property Crimes	Breaking & Entering	Larceny	Crimes Against Persons	Animal Control Calls	Assaults	Mental Commit.	Drug Arrests
<b>Current:</b>	15-Aug	8	2	13	4	42	1	4	2
<b>Last Month:</b>	15-Jul	12	2	2	2	38	2	1	2
<b>Last Year:</b>	14-Jul	12	9	7	5	35	4	7	5
Traffic Offense	Other Arrest	Juvenile Arrest	Total Arrest	Reports	Papers Served	Armed Robbery	Calls Answered	Building Checks	Avg. Jail Population
141	17	0	160	213	87	0	1,409	333	
265	17	0	284	330	87	0	1,567	396	0
72	27	0	104	167	112	0	990	272	0

<b>Calls Answered:</b>	1,409
<b>Average:</b>	45.5

<b>Calls for Service 2015:</b>	8,532
<b>Calls for Service 2014:</b>	9876
<b>Calls for Service 2013:</b>	12335

### Trainings

Body Worn Cameras  
 Field Training Officer  
 Instructor Training

# Albemarle Resource Conservation & Development Council, Inc.

## Annual Report 2014-2015

Photo: Linda Peterson



### Pembroke Creek Park Improvement (Chowan)

#### Mission

To wisely conserve natural resources & create opportunities for positive economic & community development.

#### Areas of Expertise

- Constructed wetlands
- Outdoor environmental classrooms
- Shoreline stabilization
- Water management
- Watershed management plans
- Sustainable energy
- Public water access design
- Parks & recreation design
- Nature tourism

Pembroke Creek Park is an important resource for public access to Pembroke Creek and surrounding waters in Chowan County. Residents and visitors use the park for fishing, kayaking and nature tourism. Bass fishing clubs use the park for parking and tournament events every year.

Chowan County received a \$149,720 CAMA grant in 2014 to improve water access to this recreational setting.

During **Phase I**, a vinyl bulkhead was installed to reclaim the eroded shoreline, portions of the boardwalk were replaced, and gravel parking areas with solar lighting and handicapped accessibility were created.

**Phase II** will include the construction of two 50' fishing piers and a handicap canoe/kayak launch platform.

The project will be completed by Fall 2015.

Albemarle RC&D provided grant writing and technical assistance to Chowan County and the Edenton-Chowan Parks and Recreation Department.

**The Return-On-Investment to Chowan County for this project was \$23:1.**



Photos: Mark Powell

#### 2015 Council Members

##### CAMDEN

Brian Lannon, At-Large  
Garry Meiggs  
Abner Wayne Staples

##### CHOWAN

Fenton Eure,  
Secretary/Treasurer  
Jeff Smith

##### CURRITUCK

Mike Doxey  
W. Harvey Roberts

##### DARE

Louise Hanson  
Jim Winebarger, Vice-Chair

##### GATES

Joe Harrell  
Natalie Rountree

##### HYDE

Charles Tooley  
Dick Tunnell

##### PASQUOTANK

Michele Aydlett  
Maurice Berry, Jr.  
Travis Burke

Rodney Johnson, Past Chair  
Frankie Meads

##### PERQUIMANS

Maurice Bunch  
Charles Mathews

##### TYRRELL

Nathan T. Everett  
Trey Liverman  
Rhett White

##### WASHINGTON

Milton Cahoon  
Buster Manning  
Perlis Nixon



## *Tyrrell County Waterfront Park*

The original 1.3 acre Veterans' Park in Tyrrell County was developed as a memorial park to honor its veterans. Local residents and visitors used the park for picnicking and fishing, but damage during Hurricane Isabel compromised the safety and public access to the area. The monuments were relocated beside the courthouse, but the park remained in disrepair.

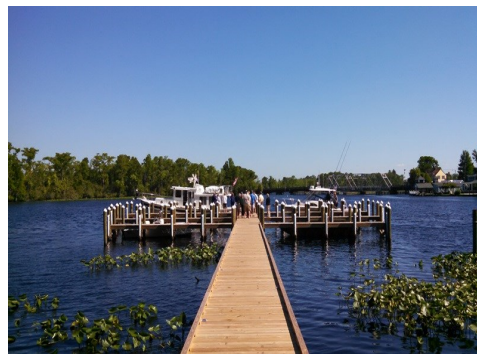

*Photo: Mark Powell*

In 2014, Tyrrell County was awarded a \$85,500 grant from the NC Public Beach and Coastal Waterfront Access Program (CAMA) to improve public access to the park on the Scuppernong River across from the Columbia waterfront. Renamed the Tyrrell County Waterfront Park, renovations will include a new gazebo, fishing pier and picnic facilities.

Albemarle RC&D assisted Tyrrell County with project design and grant writing. The council is also assisting the county with project management during the construction phase.

**The Return-On-Investment to Tyrrell County  
for this project was \$15:1.**



*Photo: Mark Powell*

## *Hertford Marina (Perquimans)*

Hertford has a rich colonial and maritime history tied to the Perquimans River and the Albemarle Sound. Waterfront development has been a priority of town leaders to attract visiting boaters to the downtown area.

A new town dock close to the Municipal Park and a nine-slip marina equipped with water, electric service and pump-out lines are now available to attract boaters, increase visitor traffic and support economic development and revitalization of the Historic Waterfront. The project was made possible through grants totaling \$100,000 from the NC Public Beach and Coastal Waterfront Access Program (CAMA) and the NC Boating Infrastructure Grant (BIG).

Albemarle RC&D assisted the Town of Hertford with the grant applications, design and management support.

**The Return-On-Investment to the Town of Hertford**

**2015-2016**

### **ARC&D Board of Directors**

#### **Chairman—**

**Nathan (Tommy) Everett,  
Tyrrell**

#### **Vice Chairman—**

**Jim Winebarger, Dare**

#### **Secretary/Treasurer—**

**Fenton Eure, Chowan**

#### **At-Large—**

**Brian Lannon,  
Camden**

#### **Past Chairman—**

**Rodney Johnson,  
Pasquotank**



**Marshall Stevenson  
(Pasquotank) was elected  
to serve as *Treasurer* of  
the Southeast Regional As-  
sociation of RC&D Councils  
and *Special Liaison* for the  
NC Association of RC&D  
Councils for 2015-2016.**





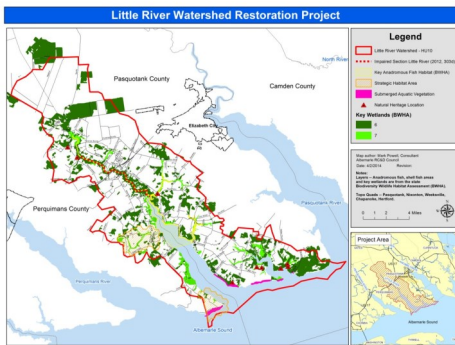

## Upper Little River Watershed Restoration

The Albemarle RC&D Council, the Albemarle Commission, Pasquotank and Perquimans Counties, Soil & Water Conservation Districts, Elizabeth City State University, Elizabeth City Bass Masters & local community groups are working together to restore the Little River Watershed, which includes about eight miles of Impaired river. The 86,000 acre watershed was once rich in biodiversity with key migratory fish areas and swamp forests critical to support native fish and wildlife, mitigate flooding and protect water quality. Over the past decades, agricultural

operations have opened drainage canals that carry sediments and nutrients directly to the river and residential and commercial developments have increased pollution from stormwater runoff. Swamp forest buffers have been eliminated or severely degraded in many river locations in Pasquotank and Perquimans Counties.

To help restore the Little River's biodiversity, the partnership is developing a number of activities including construction of in-stream wetlands on main drainage canals flowing in the Little River, conservation of swamp forest buffers, construction of fish habitat, improved public access, public outreach and environmental education, and monitoring and research.



*Photo: Mark Powell*



*Photo: Mark Powell*

Through a grant from the NC Division of Water Quality to the Albemarle Commission, a nine-element restoration plan has been developed to guide efforts to restore the Little River watershed. The plan's implementation will address the causes of Impairment by working directly with farmers, homeowners and businesses in the watershed to reduce sediment and nutrients carried by stormwater. An education and outreach program will increase public awareness of and participation in conservation and restoration of swamp forest buffers. A water quality and fisheries monitoring program along the river will help track improvements.

Perquimans County has established a voluntary program for landowners to conserve their swamp forests, which help keep sediment and nutrients from entering the river, help mitigate flooding and provide key habitat for native fish and wildlife. Pasquotank County is developing a similar program for landowners on the Pasquotank side of the Little River.

## Clearing and Snagging in Northeast NC

Recent storms and tornadoes in the region caused significant damage to drainage systems, which increased flooding in many areas. Albemarle RC&D partnered with local Soil and Water Conservation districts to obtain \$250,000 from the NC Division of Water Resources to clear and snag local canals, streams and rivers.

In the Albemarle region, 3 counties were awarded \$14,000, and 7 counties received \$10,000 to remove trees and other debris. In Chowan, Perquimans and Pasquotank Counties, sections of Burnt Mill Creek, Upper Perquimans River and the Little River were cleared of debris.

**The Return-On-Investment to each county in the Albemarle region ranged from \$8-\$37:1.**



*Pasquotank & Perquimans Counties provided funds to remove over 400 tires and trash from the river.*

*Photo: Dwayne Hinson*

**Albemarle RC&D Council  
Summary of Revenues and Expenses  
July 1st, 2014 to June 30, 2015**

**Linda Peterson,  
Program Manager**

**Circle of Diamonds**

**Albemarle RC&D received the Enhanced membership designation in 2015 by the National RC&D Association for the sixth year in a row!**

**The Circle of Diamonds Program recognizes exemplary governance practices and high management standards. As one of only 25 RC&D Councils (out of 375 nationwide) to qualify for Enhanced membership, "the policies & procedures of Albemarle RC&D make it a model for other organizations that strive to serve their communities and be good stewards of resources entrusted to them by their partners and communities."**

*Camden High School Wetlands and Outdoor Classroom*

Albemarle RC&D is working with Camden Soil and Water Conservation District and the US Fish and Wildlife Service to develop an outdoor environmental education classroom at Camden High School. The wetland would help filter stormwater from school buildings and recreational fields.

Pending grant applications will be announced in Fall, 2015.



*Photo: Brian Lannon*

**Return on Investment**

**For every dollar invested, Albemarle RC&D delivered the following return on recent projects:**

<b>Pembroke Creek Park Improvement</b>	<b>\$ 23</b>	<b>Hertford Marina</b>	<b>\$28</b>
<b>Tyrrell County Waterfront Park</b>	<b>\$ 15</b>	<b>Plymouth Waterfront (III)</b>	<b>\$ 6</b>
<b>Clearing and Snagging</b>	<b>\$ 8-37</b>		

**Albemarle RC&D offers a variety of services**

<b>Technical assistance</b>	<b>Grant Writing</b>	<b>Educational Outreach</b>
<b>Planning assistance</b>	<b>Project Management</b>	<b>Concept Development</b>

***How can we help you?***

***For more information, please contact Linda Peterson at 252-482-7437 x120.***

**Thanks to our 2014-2015 Partners**

Camden County	Albemarle Commission
Chowan County	Town of Hertford
Currituck County	Town of Plymouth
Dare County	Camden SWCD
Gates County	NC Department of Environment & Natural Resources
Hyde County	NC Public Beach and Coastal Waterfront Access Program
Pasquotank County	NC Division of Water Resources
Perquimans County	NC Clean Water Management Trust Fund
Tyrrell County	Edenton/Chowan Recreation Department
Washington County	Camden High School
Pasquotank SWCD	Elizabeth City State University

*All programs and services of the Albemarle RC&D Council are offered on a non-discriminatory basis, without regard to race, color, national origin, religion, sex, sexual orientation, age, marital or family status, disability or political beliefs.*



## United States Senate

WASHINGTON, DC 20510-3308  
(202) 224-3154 FAX: (202) 228-2981

August 26, 2015

Mr. P. McLain  
Chairman  
Camden County Board of Commissioners  
330 Easy Hwy 158  
Post Office Box 190  
Camden, North Carolina 27921

Dear Mr. McLain:

Thank you for your letter and sharing with me a resolution adopted by the Camden County Board of Commissioners in support of alternative methods of recognition for veteran status to merchant seamen of World War II (WWII). I appreciate hearing from you.

As your United States Senator, I want to express my deep appreciation for the bravery of the Merchant Marines during WWII and recognize the significant sacrifices they made on behalf of our nation. Many of them put their own lives at risk to deliver supplies and personnel to advance our nation's efforts to defeat the Axis powers. Our nation must remember and honor the contribution they made to the Allied victory.

I appreciate knowing of your support for legislation that would no longer require specific military documentation to prove an individual's service as a Merchant Mariner, specifically those members of the Merchant Marine who participated in coastwise service during WWII and who do not have documented proof of that service on a coastwise vessel. According to the United States Coast Guard and National Maritime Center, it is very rare that an individual submitting documentation to receive veteran status would not have sufficient military documentation to substantiate this status, as is required by law. A legislative change to the current law would allow individuals to provide non-military records in order to receive Veteran status. Given the new precedent this would set, it is an issue that the Senate Veterans' Affairs Committee must carefully consider.

I continue to strongly commend the gallant actions of the Merchant Marines and all other groups recognized by the Secretary of the Air Force as veterans for services rendered during WWII.

Again, thank you for your letter. Should you have any additional questions or comments, please do not hesitate to let me know.

Sincerely,



Richard Burr  
United States Senator

**Winston-Salem Office**  
2000 West First Street  
Suite 508  
Winston-Salem, NC 27104  
(336) 631-5125  
Fax: (336) 725-4493  
Toll Free: (800) 685-8916

**Wilmington Office**  
201 N. Front Street  
Suite 809  
Wilmington, NC 28401  
(910) 251-1058  
Fax: (910) 251-7975  
Toll Free: (888) 848-1833

**Rocky Mount Office**  
100 Coast Line Street  
Suite 210  
Rocky Mount, NC 27804  
(252) 977-9522  
Fax: (252) 977-7902  
Toll Free: (877) 703-2087

**Asheville Office**  
151 Patton Avenue  
Suite 204  
Asheville, NC 28801  
(828) 350-2437  
Fax: (828) 350-2439

**Gastonia Office**  
181 South Street  
Suite 222  
Gastonia, NC 28052  
(704) 833-0854  
Fax: (704) 833-1467

## Mike Renshaw

---

**From:** Newell, Jerry <newellj@co.pasquotank.nc.us>  
**Sent:** Friday, August 14, 2015 11:27 AM  
**To:** Mike Renshaw  
**Cc:** Bunch, Rodney; Small, Sheri; Meads, Walter; Holland, Deborah  
**Subject:** Camden July Response Times  
**Attachments:** July 2015 Camden Response Times.pdf

Mr. Renshaw,

Attached you will find the breakdown of response times for calls in Camden from 7:00 a.m. to 9:00 p.m. for each day of July 2015. These calls were inclusive of 911 dispatched calls only which the ambulance was dispatched and arrived on scene. Canceled calls and convalescent transports were not included in this breakdown, as canceled calls would have no on-scene time and convalescent calls would typically show a response time of "0" minutes.

Jerry Newell, EMT-P  
Director  
Pasquotank-Camden EMS  
252-335-1524 (Office)  
252-338-4650 (Cell)  
252-335-2560 (Fax)



## Pasquotank-Camden EMS Camden Response Times - July 2015

Call Date	Location	En Route	On Scene	Response Time
7/2/2015	1417 S 343 Hwy	10:33	10:48	0:15
	267 Ivy Neck Rd	16:38	16:43	0:05
	426 Old Swamp Rd	20:49	21:06	0:17
7/3/2015	140 Keeter Barn Rd	14:06	14:07	0:01
7/4/2015	191 W US 158 HWY	13:03	13:10	0:07
	315 Main Rd	20:47	20:55	0:08
7/5/2015	140 Keeter Barn Rd	13:06	13:13	0:07
	110 Cedar Branch Rd	15:37	15:52	0:15
7/7/2015	368 Lambs Rd	10:49	10:55	0:06
	476 North River Rd	16:32	16:44	0:12
	724 N Hwy 343	16:36	16:46	0:10
	158/Havenwood	19:13	19:18	0:05
	100 W US 158 Hwy	19:26	19:33	0:07
7/8/2015	217 Lamb's Rd	17:00	17:10	0:10
	300 Bridge Ct	19:38	19:42	0:04
7/9/2015	101 Park Dr	12:46	12:56	0:10
	154 Dock Landing Loop	18:15	18:21	0:06
7/11/2015	744 Sandy Hook Rd	7:38	7:57	0:19
	284 Lamb's Rd	16:21	16:27	0:06
7/13/2015	109 Bourbon St	13:02	13:06	0:04
7/14/2015	117 N 343	13:32	13:34	0:02
	217 N 343 Hwy	19:52	19:53	0:01
7/17/2015	Upton Rd/Seymour	9:14	9:17	0:03
7/20/2015	217 Lamb's Rd	10:57	11:03	0:06
	894 N 343 Hwy	21:02	21:13	0:11
7/23/2015	206 Maddrey Dr	8:53	8:59	0:06
	158 Country Club Road	18:31	18:36	0:05
7/24/2015	103 Camden Ave	15:54	16:07	0:13
	163 Upton Rd	19:57	20:01	0:04
7/25/2015	140 Keeter Barn Rd	14:09	14:10	0:01
7/27/2015	600 Main St	11:53	11:58	0:05
	230 Lilly Rd	13:03	13:08	0:05
	114 Long Pine Rd	14:14	14:17	0:03
	2871 US 17 Hwy	14:24	14:35	0:11
	315 Main Rd	16:50	16:56	0:06
	300 Bridge Ct	18:23	18:26	0:03
	104 Elliott Dr	19:50	20:05	0:15
7/28/2015	143 Pier Landing Loop	9:42	9:58	0:16
	744 Sandy Hook Rd	12:00	12:16	0:16
7/29/2015	379 Old Swamp Road	13:21	13:24	0:03
7/31/2015	102 McCoy Rd	9:19	9:26	0:07
	2362 US 17 Hwy	13:50	13:56	0:06
	214 Riverview Ave	16:52	17:02	0:10
<b>Camden Average Response Times</b>				<b>0:07</b>

# Emergency Medical Services Board Agenda

August 12, 2015

- Approval of Minutes
- EMS Nurse Liaison's Report
- Rescue Squad Report
- Volunteer Coordinator Presentation
- Medical Director's Report
- County Manager's Report
  - Pasquotank County
  - Camden County
- EMS Department Report
- New Business
- Closed Session
- Adjournment

**Monthly Report  
for  
July 2015**

<b>Ambulance Responses:</b>	MTD 2015-2016	MTD 2014-2015	YTD 2015-2016	YTD 2014-2015	
Total Responses	1019	941	1019	941	
Camden County	58	50	58	50	
Blackwater	0		0		
Pasquotank County	791	693	791	693	
Albemarle Hospital	170	198	170	198	
Advanced Life Support	305	288	305	288	
Basic Life Support	499	458	499	458	
Treatment/No Tx	6	1	6	1	<b>Emergency Transports</b>
Patient Refusal	110	88	110	88	73
Cancelled Enroute	29	32	29	32	
Standby-Event	8	9	8	9	<b>Non-Emergency Transports</b>
Standby-Helo	0		0		
Standby-Fire	7	6	7	6	401
Mutual Aid	2	3	2	3	
Miscellaneous	53	56	53	56	
	1019	941	1019	941	
<b>Accounts Receivable:</b>	<b>MTD</b>		<b>YTD</b>		<b>LYYTD</b>
A/R Beginning Balance	\$ 1,656,925.77	+			
Patient Billings	\$ 418,947.60	+	\$ 418,947.60		\$ 399,908.60
Refunds	\$ 354.52	+	\$ 354.52		\$ 2,497.66
Patient Credits	\$ 202,624.70	-	\$ 202,624.70		\$ 238,534.03
Ins. Contract Adj.	\$ 88,604.74	-	\$ 88,604.74		\$ 101,010.35
Write Off's	\$ 31,727.39	-	\$ 31,727.39		\$ 38,341.11
Late PCR's		+			
Adjustment	\$ 2,024.29	+			
A/R Ending Balance	\$ 1,755,295.35			<b>LYMTD</b>	
Deposits to Finance Office	\$ 136,786.24	+	\$ 180,506.96		
Recovery from Bad Debt	\$ 263.63	-			
Misc. Revenue	\$ 111.08	-			
A/R Payment to Finance	\$ 66,213.17	+			
Adjustment Added	\$ -	+			
Adjustment Subtracted	\$ -	-			
Total	\$ 202,624.70				

**Notes:**  
Ins, Mileage Adj

**EMS Board Minutes  
July 8, 2015**

The Pasquotank-Camden Emergency Medical Services Board meeting was held on Wednesday, July 8, 2015, at the Pasquotank-Camden EMS Administrative Building.

Ms. Sue Meads called the meeting to order at 2:03 p.m.

**Members Present:**

Jeff Dixon  
Tom White  
Garry Meiggs  
Chris Ayers  
Sue Meads  
Mike Straka

**Members Absent:**

Frankie Meads  
Rodney Bunch (Excused)  
Carolyn Aydlett (Excused)

**Others Present:**

Michael Renshaw  
Jerry Newell  
Walter Meads  
Nettie Marshall  
Deborah Holland  
Carla Godwin  
Kelly Schweers  
Sherri Small

The minutes from the May meeting were reviewed. Mr. Tom White made a motion to accept the minutes. Mr. Jeff Dixon seconded the motion. The motion carried.



**Sentara Albemarle Medical Center:**

- Ms. Kelly Schweers provided a report on the turnaround times in the ER for June and total number of patients seen from January through June. (See Attachment below)
- Ms. Schweers reported that July 21st will be open house with EMS at 4:30 p.m.
- Ms. Schweers also provided an example as shown as an attachment below of the new white boards provided in the ER.

**Rescue Squad:**

- Mr. Chris Ayers presented information regarding hiring a Volunteer Coordinator to assist in management and to promote the Pasquotank County Rescue Squad.
- Mr. Ayers stated that the position will require EMT basic certification.
- The position will be part time working 24 hours per week with an estimated annual salary of \$18,000.
- Mr. Ayers stated that some goals for adding a Volunteer Coordinator are to increase permanence between the two organizations and provide a cost savings to the county by providing staff to cover shifts for the career staff.
- A consensus was made to move forward with making plans to hire a Volunteer Coordinator.

**Medical Director:**

- None. Mike Straka was present at the meeting but ended up on an emergency call.

**County Managers:**

- Ms. Sheri Small was in attendance for Rodney Bunch.
- Ms. Small provided the Revenue/Expenditure Report.
- Ms. Small informed that we will be receiving \$160, 000 from the Medicaid Cost Reimbursement to be put towards revenue which is better than what we anticipated.
- The collection percentage for this year was 61.65%.
- Mr. Michael Renshaw reported that they recently had installed a radio new system at Station 14 costing up to 3,000 dollars due to not being able to hear the pages coming in.

**EMS Department:**

- Mr. Jerry Newell provided the Financial Report for June stating that the call volume has increased.
- Rescue 8 is finished and was picked up on the 29th of June.
- Rescue 6 will be remounted and ready by the end of September through early October.

**New Business:**

- None

**Closed Session:**

- None

With no further business to discuss, Mr. Jeff Dixon made a motion to adjourn the meeting. Mr. Gary Meiggs seconded the motion. The motion carried.

The meeting was adjourned at 2:37 p.m. The next EMS Board Meeting is scheduled for Wednesday August 12, 2015 at 2:00 p.m. in the conference room of the EMS Administrative Building.

# Emergency Medical Services Board Agenda

September 9, 2015

- Approval of Minutes
- EMS Nurse Liaison's Report
- Rescue Squad Report
- Volunteer Coordinator Presentation
- Medical Director's Report
- County Manager's Report
  - Pasquotank County
  - Camden County
- EMS Department Report
- New Business
- Closed Session
- Adjournment

## Pasquotank-Camden EMS FY 2016 Projections

Month	FY 2016 Call Volume	FY 2016 Collections	FY 2016 Expenditures
July	1019	\$202,625	\$520,509
August	1065	\$235,353	\$355,308
September			
October			
November			
December			
January			
February			
March			
April			
May			
June			
<b>Encumbrances</b>			<b>\$219,111</b>
<b>FY 2015 Actual Totals</b>	<b>2084</b>	<b>\$437,978</b>	<b>\$1,094,928</b>
<b>FY 2015 Projections</b>	<b>10080</b>	<b>\$2,730,600</b>	<b>\$4,339,450</b>
<i>% of projections</i>	<i>21%</i>	<i>16%</i>	<i>25%</i>

**Monthly Report  
for  
August 2015**

<b>Ambulance Responses:</b>	MTD 2015-2016	MTD 2014-2015	YTD 2015-2016	YTD 2014-2015	
Total Responses	1065	895	2084	1836	
Camden County	63	44	121	94	
Blackwater	0		0	0	
Pasquotank County	785	670	1576	1363	
Albemarle Hospital	217	181	387	379	
Advanced Life Support	319	272	624	560	
Basic Life Support	524	442	1023	900	<b>Emergency</b>
Treatment/No Tx	10	5	16	6	<b>Transports</b>
Patient Refusal	99	79	209	167	94
Cancelled Enroute	45	31	74	63	
Standby-Event	6	6	14	15	<b>Non-Emergency</b>
Standby-Helo	0	0	0	0	<b>Transports</b>
Standby-Fire	5	7	12	13	376
Mutual Aid	1	1	3	4	
Miscellaneous	56	52	109	108	
	1065	895	2084	1836	
<b>Accounts Receivable:</b>	<b>MTD</b>		<b>YTD</b>		<b>LYYTD</b>
A/R Beginning Balance	\$ 1,755,295.35	+			
Patient Billings	\$ 463,478.00	+	\$ 882,425.60		\$ 784,619.80
Refunds	\$ 1,490.63	+	\$ 1,845.15		\$ 3,804.36
Patient Credits	\$ 235,353.32	-	\$ 437,978.02		\$ 430,184.40
Ins. Contract Adj.	\$ 118,550.18	-	\$ 207,154.92		\$ 202,953.07
Write Off's	\$ 12,227.48	-	\$ 43,954.87		\$ 70,805.15
Late PCR's		+			
Adjustment	\$ 2,689.41	+			
A/R Ending Balance	<u>\$ 1,856,822.41</u>		<b>LYMTD</b>		
Deposits to Finance Office	\$ 164,042.59	+	\$ 127,193.01		
Recovery from Bad Debt	\$ 23.62	-			
Misc. Revenue	\$ 119.40	-			
A/R Payment to Finance	\$ 71,453.75	+			
Adjustment Added		+			
Adjustment Subtracted		-			
Total	<u>\$ 235,353.32</u>				

**Notes:**  
Mileage/ins

**EMS Board Minutes  
August 12, 2015**

The Pasquotank-Camden Emergency Medical Services Board meeting was held on Wednesday, August 12, 2015, at the Pasquotank-Camden EMS Administrative Building.

Ms. Sue Meads called the meeting to order at 2:03 p.m.

**Members Present:**

Tom White

Garry Meiggs

Sue Meads

Mike Straka

Frankie Meads

**Members Absent:**

Jeff Dixon

Chris Ayers (Excused)

**Others Present:**

Michael Renshaw

Rodney Bunch

Jerry Newell

Walter Meads

Nettie Marshall

Deborah Holland

Carla Godwin

Kelly Schweers

Jamie Carol

The minutes from the May meeting were reviewed. Mr. Tom White made a motion to accept the minutes. Mr. Gary Meiggs seconded the motion. The motion carried.

**Sentara Albemarle Medical Center:**

- Ms. Kelly Schweers provided a report included in the attachments showing updates for July, recent initiatives, patient experience, nursing updates, and hospital updates.

**Rescue Squad:**

- Ms. Sue Meads reported that they are still currently working on hiring a Volunteer Coordinator for the Rescue Squad.

**Medical Director:**

- Mr. Mike Straka reported that they will start updating protocols within the next several months and are currently working on online training.

**County Managers:**

- Mr. Michael Renshaw thanked Mr. Jerry Newell for the AED installation at the Camden County Library.
- Mr. Renshaw mentioned he received a call from Mrs. Donna Stuart (Visitor Center Director) for a possible AED installation in the near future.
- Mr. Newell commented that the AED's we have are currently spoken for unless someone decides to not to get one installed then we will have an extra AED to install at the Visitor Center.

**EMS Department:**

- Mr. Jerry Newell provided the Financial Report and Revenue/Expenditure report for July.
- Mr. Newell reported that call volume is still steadily increasing.
- AED placements have been made by Pasquotank-Camden EMS at the Camden County Library, the Public Safety Building and South Park Sports Complex.
- Mr. Newell stated that July 17<sup>th</sup> they will install an AED in the Pasquotank County Library and that the Board of Elections will have one installed as well.
- Mr. Newell stated that the remount is in at Northwestern Emergency Vehicles and will be ready sometime between the end of August or the 1<sup>st</sup> of September.
- Mr. Newell commented on the contribution we made about four years ago to Nightingale on the purchase of the new helicopter.
- There is a letter attached from Ms. Denise Baylous (Nightingale Manager) included thanking us for our contribution.

**New Business:**

- None

**Closed Session:**

- None

With no further business to discuss, Mr. Rodney Bunch made a motion to adjourn the meeting. Mr. Frankie Meads seconded the motion. The motion carried.

The meeting was adjourned at 2:12 p.m. The next EMS Board Meeting is scheduled for Wednesday September 9, 2015 at 2:00 p.m. in the conference room of the EMS Administrative Building.





## Updates July 2015:

	Dec 2014	Jan 2015	Feb 2015	Mar 2015	Apr 2015	May 2015	Jun 2015	July 2015
Volume	4118	3709	3413	3826	3653	3938	3741	3879
Admissions	434	448	420	465	407	435	395	410
LWBS	8.0%	4.5%	3.9%	2.5%	1.9%	2.1%	2.3%	1.7%
Transfers	84	90	92	108	102	116	94	79
Length of Stay-Admitted - median	353	358	321	346	292	304	309	296
Length of Stay-Discharged- median	158	161	147	142	132	126	130	132
Door to provider- median	33	24	25	20	16	15	14	16
In bed to provider- median	3	4	3	3	4	3	3	3
Initial contact until care complete- median	75	88	87	87	90	85	86	85
Top Box Patient Satisfaction for discharged patients	40.6%	57.1%	56.7%	30.8%	46.4%	54.5%	50.0%	66.7%

### Recent Initiatives

Participated in Coast Guard Open House Outreach event

Partnering with Virginia Beach as sister hospital to facilitate ED transfers, as well as continuing to work with SNGH

Met with local magistrates to improve IVC process

Arranging table talk with local PD and county sheriff in response to June ED shooting



Obtained new fetal and venous Doppler, ophthalmic burr, End tidal Co2 Module and vein finder

#### Patient Experience

- Departmental brochures being created for greater patient awareness of ED experience
- Continuing patient discharge follow up calls and leadership rounding
- Implemented customized discharge envelopes with specific discharge coordinator follow up instructions

#### Nursing Update

- Nurse Educator Mike Mitchell on board, 6 nurses and 5 techs hired
- Nursing Initiated Triage protocols submitted for psqe approval

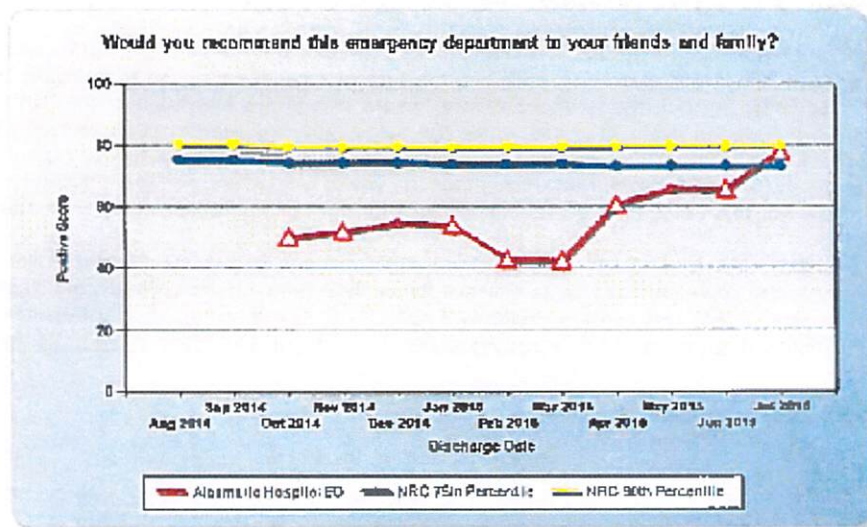

#### Hospital Updates

10 in-patient beds opened on the third floor

Nurse Director will start September 8<sup>th</sup>, Bonnie Thrift



Sentara Foundation - Hampton Roads  
6013 Poplar Hall Drive, Suite 308  
Norfolk, VA 23502

757-455-7976  
757-455-7560 (Fax)  
www.sentara.com/foundation

July 31, 2015

Mr. Jerry Newell  
Pasquotank-Camden Emergency Medical Services  
PO Box 469  
Elizabeth City, NC 27907

Dear Mr. Newell,

As the summer comes to an end, we want you to know that your prior gift to the Nightingale Air Ambulance still saves lives every single day. It has been a little over four years since our new Nightingale went into service, and we have not only continued our important missions, but have gained recognition for its dedicated nurses and safety record.

Nightingale serves patients from the Eastern Shore to Ahoskie, NC and from Williamsburg to the Outer Banks of North Carolina, who otherwise would not have had a chance at survival. Below are just a few of those grateful individuals who were given a second chance at life thanks to YOUR support.

- In 1982, ten-year-old Marty Salo was riding his bike home from the library when he was struck by a car. The ground ambulance could not reach him because of a passing train, so Nightingale was called to the scene. Severely injured, Marty spent several weeks in a coma and his doctors didn't think his brain would ever function again. One day, while the Salos agonized over whether to take Marty off of life-support, Marty miraculously reached up and touched his nose. Thanks to the Nightingale and YOUR generous support of this program throughout the years, Marty has received a second chance at life. To learn how Marty is doing now, 33 years later, look for our upcoming Newsletter in September.

The new Nightingale aircraft conducts over 600 life-saving missions a year. New features like the night vision goggles have made the crew and patients safer while flying night time missions. Today, the Nightingale is one of the signature programs that sets Sentara Healthcare apart as the premier provider of hospital and health care services in this region. Your support has saved lives, like those above, and given many patients second chances at life.

Thank you for your generosity.

A handwritten signature in black ink that reads "Denise Baylous".

Denise Baylous, MSN, RN, CCRN, CFRN, NREMT-P  
Nightingale Manager

A handwritten signature in black ink that reads "Meril Amdursky".

Meril Amdursky  
Foundation Executive Director

**Pasquotank-Camden EMS Camden Response Times - August 2015**

*Times measured are from 0700 to 2100 when at least one ambulance is stationed in Camden*

<b>Call Date</b>	<b>Location</b>	<b>Dispatched</b>	<b>On Scene</b>	<b>Response Time</b>
8/2/2015	284 Lamb's Road	14:58	15:07	0:09
	101 General's Way	17:35	17:40	0:05
8/3/2015	207 E US 158	7:25	7:32	0:07
	134 Belcross Rd	11:50	11:56	0:06
	200 Bridge Ct	18:11	18:23	0:12
8/5/2015	103 Edgewater Dr	13:26	14:01	0:35
	744 Sandy Hook Rd	14:08	14:23	0:15
	744 Sandy Hook Rd	18:28	18:50	0:22
8/6/2015	US17/Keeter Barn Rd	7:56	7:57	0:01
8/8/2015	117 Morrisette's Rd	11:52	11:55	0:03
	130 Cartwright Rd	15:47	15:51	0:04
	142 Lauren Ln	20:11	20:20	0:09
8/9/2015	288 Belcorss Rd	16:19	16:26	0:07
	121 Bloodfield Rd	20:19	20:23	0:04
8/10/2015	102 Main St	13:50	13:56	0:06
	102 Main St	15:40	15:44	0:04
8/11/2015	221 Keeter Barn Rd	14:01	14:04	0:03
8/12/2015	1286 N 343	11:08	11:15	0:07
	Old Swamp/Lilly Rds	17:07	17:12	0:05
	288 Belcorss Rd	19:10	19:17	0:07
	140 Beech Neck Rd	19:19	19:36	0:17
8/13/2015	140 Keeter Barn Rd	11:53	11:54	0:01
8/14/2015	140 Keeter Barn Rd	7:31	7:34	0:03
	227 Neck Rd	15:13	15:23	0:10
	225 Keeter Barn Rd	16:26	16:29	0:03
	108 Griffin Rd	17:41	17:53	0:12
8/15/2015	288 Belcorss Rd	15:26	15:33	0:07
8/16/2015	140 Keeter Barn Rd	8:14	8:27	0:13
	103 E US 158	15:21	15:24	0:03
8/19/2015	107 E US 158	18:48	18:50	0:02
8/21/2015	207 Riverview Ave	13:00	13:12	0:12
	1348 N 343	14:48	14:53	0:05
8/22/2015	274 Belcross Rd	9:29	9:35	0:06
	747 Sandy Hook Rd	17:22	17:36	0:14
8/23/2015	331 N 343	19:31	19:38	0:07
8/25/2015	207 Muddy Rd	12:14	12:24	0:10
	102 McCoy Rd	12:17	12:34	0:17
	269 E US 158	15:11	15:17	0:06
8/26/2015	1083 N 343	14:10	14:16	0:06
	2362 US 17 Hwy	15:11	15:19	0:08
8/26/2015	1134 N 343	19:56	20:09	0:13
8/29/2015	191 W US 158	16:42	16:47	0:05
	447 Trotman Rd	19:50	20:02	0:12
8/30/2015	117 N 343	15:21	15:23	0:02
8/31/2015	451 Wickham Rd	7:37	7:57	0:20
8/31/2015	189 Scotland Rd	13:02	13:08	0:06
<b>Camden Average Response Times</b>				<b>0:08</b>



2015 Eastern 4-H Shooting Sports Tournament Attendance

County	4-H Participants	4-H Volunteers	Parents	Extension Staff	Other	Total
Camden	17	15	12	1		45
Eastern 4-H Center				2	12	14
Edgecombe	16	4	12	2		34
Franklin	11	4	12			27
Greene	7	5	10	0	0	22
Johnston	15	8	11			34
Lenoir	17	7	34	2		60
Nash	14	4	9	1		28
Pamlico	12	3	20			35
Pender	11	4	14			29
Pitt	6	3	7			16
Wilson	22	7	17			46
Wayne	6	2	1	1		10
Other						

TOTAL	154	66	159	9	12	400
-------	-----	----	-----	---	----	-----

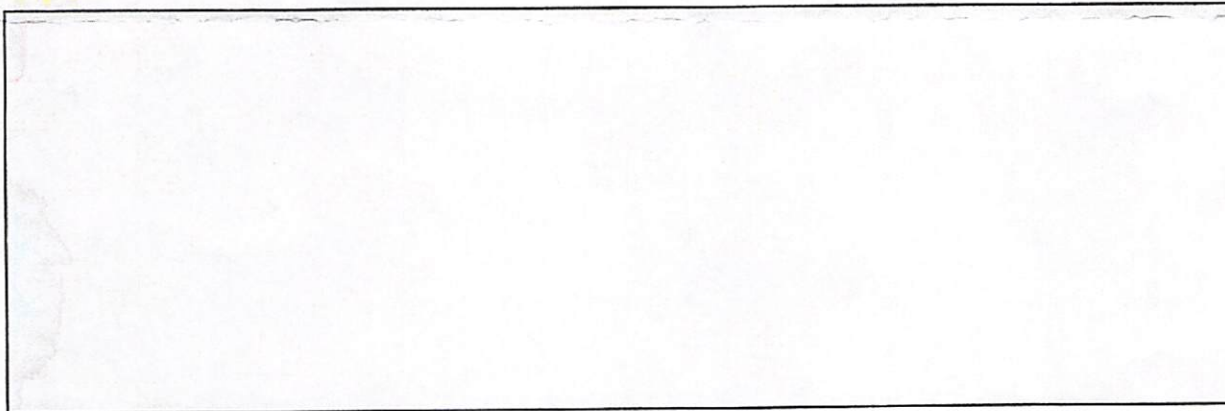



OFFICE OF THE PRESIDENT

DR. KANDI W. DEITEMEYER

August 20, 2015

Camden County Board of Commissioners  
P.O. Box 190  
Camden, NC 27921

Dear Commissioners:

As you know, College of The Albemarle has recently adopted its 2016-21 Strategic Plan with three main areas of focus: "Engage, Transform, Invest." A central piece to the success of this plan will be the continuing collaboration between COA and our community stakeholders. We are extremely grateful for the partnership and support of Camden County.

On behalf of the Board of Trustees, myself, faculty, staff and our students, please accept my personal thanks for your generosity and support of College of The Albemarle. The appropriation of \$40,000 will help us to improve and maintain the quality of college operations and facilities on campus.

We will continue to be good stewards of these resources and we thank you for your ongoing partnership in helping students find success at College of The Albemarle. I hope that Camden County has a very successful year. If I can be of any assistance, please do not hesitate to contact me.

Sincerely,

Kandi W. Deitemeyer, Ed.D.  
President  
College of The Albemarle

CC: Mike Renshaw, County Manager

1  
2                   **Camden County Board of Equalization & Review**  
3                               **July 6<sup>th</sup>, 2015**  
4                   **Historic Courtroom, Courthouse Complex**  
5                               **Camden, North Carolina**  
6

7  
8   **MINUTES**  
9

10  
11 The Camden County Board of Equalization & Review met on July 6th, 2015 in the  
12 Historic Courtroom, Camden, North Carolina. The following Board Members were  
13 present:

14  
15   Chairman Michael McLain,  
16   Commissioners Tom White, Garry Meiggs and Clayton Riggs;

17  
18   Vice Chairwoman Sandra Duckwall was absent  
19

20 Also attending were County Manager Michael Renshaw, Clerk to the Board Angela  
21 Wooten, Tax Administrator Lisa Anderson. Present for purposes of presenting tax cases  
22 were the following persons: Bob Pearson of Pearson Appraisals.  
23

24  
25                   **Call to Order**  
26

27 Chairman Michael McLain called to order the July 6th, 2015 meeting of the Camden  
28 County Board of Equalization & Review at 6:99 PM.  
29

30  
31                   **Swearing in of Board Members**  
32

33 Clerk to the Board Angela Wooten swore in Board of Equalization & Review members  
34 Chairman Michael McLain and Commissioners Tom White, Garry Meiggs and Clayton  
35 Riggs.  
36

37  
38  
39  
40  
41                   **Cases**  
42

---

43 *Tax Payer Name:*       *Roy McCoy*  
44 *Address in Question:* *149 Cartwright Rd*  
45 *Chief Complaint:*       *Building value should not have increased*  
46

CAMDEN COUNTY BOARD OF COMMISSIONERS  
Board of Equalization & Review – July 6th, 2015

---

47  
48  
49  
50  
51  
52  
53  
54  
55  
56  
57  
58  
59

Roy McCoy came before the Board of Equalization & Review and presented the following information regarding the above address:

- Before Revaluation
  - Total property value in 2014 was \$74,330.
- After Revaluation
  - The building value increased by \$12,000
  - The Land value decreased by \$12,000
- There have not been any updates to the property since the last revaluation there for the increase to the value of his building is not consistent with the average 20% decrease in values seen across the county.

60

---

---

61  
62  
63

**Meeting Recessed**

64  
65  
66  
67

At 6:30 PM, Chairman Michael McLain asked if there were any other matters to come before the Board of Equalization & Review, hearing none, and by acclamation the meeting was recessed until September 21<sup>st</sup>, 2015 at 6:00 PM.

68  
69  
70  
71  
72

---

Chairman Michael McLain  
Board of Equalization & Review

73  
74  
75  
76

ATTEST:

77  
78  
79  
80  
81

---

Angela L. Wooten  
Clerk to the Board

82  
83